

The power behind competitiveness

Delta UPS - Modulon Family

DPH Series, Three Phase
15-60 kVA 208Vac

User Manual

SAVE THIS MANUAL

This manual contains important instructions and warnings that you should follow during the installation, operation, storage and maintenance of this product. Failure to heed these instructions and warnings will void the warranty.

Copyright © 2021 by Delta Electronics Inc. All Rights Reserved. All rights of this User Manual ("Manual"), including but not limited to the contents, information, and figures are solely owned and reserved by Delta Electronics Inc. ("Delta"). The Manual can only be applied to the operation or the use of this product. Any disposition, duplication, dissemination, reproduction, modification, translation, extraction, or usage of this Manual in whole or in part is prohibited without the prior written permission of Delta. Given that Delta will continuously improve and develop the product, changes may be made to the information in this Manual at any time without obligation to notify any person of such revision or changes. Delta will make all possible efforts to secure the accuracy and the integrity of this Manual. Delta disclaims any kinds or forms of warranty, guarantee, or undertaking, either expressly or implicitly, including but not limited to the completeness, faultlessness, accuracy, non-infringement, merchantability or fitness for a particular purpose of the Manual.

Table of Contents

1.	Important Safety Instructions	1-1
1.1	Installation Warnings	1-2
1.2	Connection Warnings	1-2
1.3	Usage Warnings	1-4
1.4	Storage Warnings	1-5
1.5	Standard Compliance	1-5
2.	Introduction	2-1
2.1	General Overview	2-2
2.2	Package Inspection	2-2
2.3	Functions & Features	2-4
2.4	Exterior and Dimensions	2-6
2.5	Front View	2-6
2.6	Internal View	2-8
2.7	Rear View	2-12
2.8	Tri-color LED Indicator & Buzzer	2-13
3.	Operation Modes	3-1
3.1	Single Input	3-2
3.1.1	Online Mode_ Single Input_ Single Unit	3-2
3.1.2	Battery Mode_ Single Input_ Single Unit	3-3
3.1.3	Bypass Mode_ Single Input_ Single Unit	3-3
3.1.4	Manual Bypass Mode_ Single Input_ Single Unit	3-4
3.1.5	ECO Mode_ Single Input_ Single Unit	3-5
3.1.6	Frequency Conversion Mode_ Single Input_ Single Unit	3-5
3.1.7	Green Mode_ Single Input_ Single Unit	3-6
3.1.8	Energy Recycle Mode_ Single Input_ Single Unit	3-7
3.1.9	Online Mode_ Single Input_ Parallel Units	3-8
3.1.10	Battery Mode_ Single Input_ Parallel Units	3-9
3.1.11	Bypass Mode_ Single Input_ Parallel Units	3-10
3.1.12	Manual Bypass Mode_ Single Input_ Parallel Units	3-11
3.1.13	ECO Mode_ Single Input_ Parallel Units	3-13
3.1.14	Frequency Conversion Mode_ Single Input_ Parallel Units	3-14
3.2	Dual Input	3-15
3.2.1	Online Mode_ Dual Input_ Single Unit	3-15
3.2.2	Battery Mode_ Dual Input_ Single Unit	3-15
3.2.3	Bypass Mode_ Dual Input_ Single Unit	3-16

3.2.4	Manual Bypass Mode_ Dual Input_ Single Unit	3-17
3.2.5	ECO Mode_ Dual Input_ Single Unit	3-18
3.2.6	Frequency Conversion Mode_ Dual Input_ Single Unit	3-19
3.2.7	Green Mode_ Dual Input_ Single Unit	3-20
3.2.8	Online Mode_ Dual Input_ Parallel Units	3-21
3.2.9	Battery Mode_ Dual Input_ Parallel Units	3-22
3.2.10	Bypass Mode_ Dual Input_ Parallel Units	3-23
3.2.11	Manual Bypass Mode_ Dual Input_ Parallel Units	3-24
3.2.12	ECO Mode_ Dual Input_ Parallel Units	3-26
3.2.13	Frequency Conversion Mode_ Dual Input_ Parallel Units	3-27
3.3	Hot Standby Redundancy (Only for Dual Input & at Least Two UPSs)	3-28
3.4	Common Battery (Only for Parallel UPSs Connecting to the Same External Battery Cabinet(s))	3-29

4. Communication Interfaces ----- 4-1

4.1	Communication Interfaces on the Front of the UPS with Front Door Open	4-2
4.1.1	Display Port	4-3
4.1.2	REPO Dry Contacts	4-4
4.1.3	External Battery Temperature Dry Contacts	4-5
4.1.4	External Switch/ Breaker Status Dry Contacts	4-6
4.1.5	Output Dry Contacts	4-7
4.1.6	Input Dry Contacts	4-9
4.1.7	Parallel Communication Cards	4-10
4.1.8	Parallel Ports	4-11
4.1.9	SMART Slot	4-11
4.1.10	USB Port & RS-232 Port	4-11
4.1.11	Auxiliary Power Cards	4-12
4.1.12	Battery Start Buttons	4-12
4.2	Communication Interfaces at the Rear of the Touch Panel	4-13

5. Installation and Wiring ----- 5-1

5.1	Before Installation and Wiring	5-2
5.2	Installation Environment	5-2
5.3	UPS Transportation	5-3
5.4	Fixing the UPS	5-4
5.5	Wiring	5-6
5.5.1	Pre-wiring Warnings	5-6
5.5.2	Single Input/ Dual Input Modification	5-8
5.5.3	Single Unit Wiring	5-11

5.5.4	Parallel Units Wiring	5-18
5.6	External Battery Cabinet Connection Warnings	5-21
5.7	STS Module	5-26
5.7.1	STS Module Installation	5-27
5.7.2	STS Module Removal	5-28
5.7.3	STS Module's LED Indicator	5-30
5.8	Power Module (Optional)	5-31
5.8.1	Power Module Installation	5-31
5.8.2	Power Module Removal	5-34
5.8.3	Power Module's LED Indicator	5-36
5.9	Battery Module (Optional)	5-37
5.9.1	Battery Module Warnings	5-38
5.9.2	Battery Module Installation	5-39
5.9.3	Battery Module Removal	5-42
5.9.4	Battery Module's LED Indicator	5-43
6.	UPS Operation	6-1
6.1	Single Unit and Parallel Units Pre Start-up & Pre Turn-off Warnings	6-2
6.2	Start-up Procedures	6-4
6.2.1	Online Mode Start-up Procedures	6-4
6.2.2	Battery Mode Start-up Procedures	6-8
6.2.3	Bypass Mode Start-up Procedures	6-10
6.2.4	Manual Bypass Mode Start-up Procedures	6-13
6.2.5	ECO Mode Start-up Procedures	6-17
6.2.6	Frequency Conversion Mode Start-up Procedures	6-21
6.2.7	Green Mode Start-up Procedures	6-25
6.2.8	Energy Recycle Mode Start-up Procedures	6-28
6.3	Turn-off Procedures	6-32
6.3.1	Online Mode Turn-off Procedures	6-32
6.3.2	Battery Mode Turn-off Procedures	6-33
6.3.3	Bypass Mode Turn-off Procedures	6-35
6.3.4	Manual Bypass Mode Turn-off Procedures	6-36
6.3.5	ECO Mode Turn-off Procedures	6-37
6.3.6	Frequency Conversion Mode Turn-off Procedures	6-39
6.3.7	Green Mode Turn-off Procedures	6-42
6.3.8	Energy Recycle Mode Turn-off Procedures	6-45
7.	LCD Display & Settings	7-1
7.1	LCD Display Hierarchy	7-2
7.2	How to Turn on the LCD	7-3

7.3	ON/ OFF Button-----	7-4
7.4	LCD and Function Key Introduction-----	7-6
7.5	Password Entry -----	7-11
7.6	Main Screen-----	7-11
7.7	Main Menu-----	7-15
7.8	Power Flow & Summary & System Status -----	7-17
7.9	Check System Readings-----	7-19
7.9.1	Main Input -----	7-19
7.9.2	Bypass Input-----	7-19
7.9.3	Inverter Output -----	7-20
7.9.4	Power Module Summary -----	7-20
7.9.5	UPS Output -----	7-21
7.9.6	Battery Status -----	7-21
7.10	UPS Settings-----	7-22
7.10.1	Bypass setting-----	7-22
7.10.2	Mode Setting -----	7-23
7.10.3	Output Setting-----	7-24
7.10.4	Battery & Charging Setting-----	7-25
7.10.5	Parallel Setting-----	7-28
7.10.6	Dry Contact Setting -----	7-29
7.10.7	General Setting -----	7-31
7.10.8	IP Setting -----	7-33
7.10.9	Control -----	7-34
7.11	System Maintenance -----	7-35
7.11.1	Warning -----	7-35
7.11.2	Historical Event -----	7-36
7.11.3	Statistics -----	7-37
7.11.4	Test-----	7-38
7.11.5	Clear-----	7-38
7.11.6	Advanced Diagnosis-----	7-39
7.11.7	Version & S/N -----	7-40
8.	Optional Accessories -----	8-1
9.	Maintenance-----	9-1
10.	Troubleshooting -----	10-1
	Appendix 1 : Technical Specifications-----	A1-1
	Appendix 2 : Warranty-----	A2-1

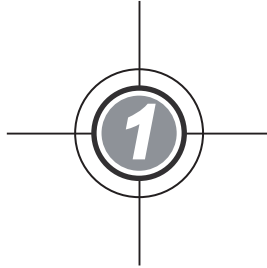

Important Safety Instructions

1.1 Installation Warnings

1.2 Connection Warnings

1.3 Usage Warnings

1.4 Storage Warnings

1.5 Standard Compliance

1.1 Installation Warnings

- This is a three-phase four-wire on-line uninterruptible power supply (hereafter referred to as 'UPS'). It can be used for commercial and industrial applications.
- Install the UPS in a well-ventilated indoor area, away from excess moisture, heat, dust, flammable gas or explosives.
- Leave adequate space around all sides of the UPS for proper ventilation and maintenance. Please refer to **5.2 Installation Environment**.
- Only authorized Delta engineers or service personnel can perform installation and maintenance. If you want to install the UPS by yourself, please install it under the supervision of authorized Delta engineers or service personnel
- All wiring and equipment should be connected and installed in accordance with NFPA 70, National Electrical Code (NEC), and the applicable sections of ANSI C2, National Electrical Safety Code (NESC). It is the responsibility of the Authority Having Jurisdiction over the final installation to determine if the final configuration meets the necessary criteria for installation and use.

1.2 Connection Warnings

- Before applying electrical power to the UPS, make sure the UPS is grounded to avoid a possible risk of current leakage.
- You can parallel UPS units. For UPS parallel information and application, please contact Delta service personnel.
- You can install at maximum sixteen battery modules (optional) inside the UPS cabinet. For relevant information, please refer to **5.9 Battery Module (Optional)**. To extend backup time, the UPS can be connected with at maximum four external battery cabinets (user-supplied, handled and configured by Delta service personnel). Please refer to **5.6 External Battery Cabinet Connection Warnings** for relevant information.
- In this user manual, the meaning of Q1, Q2 and Q3 represents the following.

Code	Meaning
Q1	Input/ Bypass Breaker
Q2	Manual Bypass Breaker
Q3	Output Breaker

- The installation of protective devices is highly recommended when the UPS is connected to power sources and critical loads.
- The protective devices connecting to the UPS must be installed near the UPS and easily accessible for operation.
- Protective Devices:
 1. For single input, please install the protective devices (1) between the main AC source and the UPS and (2) between the connected critical loads and the UPS.
 2. For dual input, please install the protective devices (1) between the main AC source and the UPS, (2) between the bypass source and the UPS and (3) between the connected critical loads and the UPS.
 3. Each protective device could be a breaker or a fuse. For the protective device's rating current, please refer to the table below.

15kVA	30kVA	45kVA	60kVA
60A	125A	175A	225A

4. For selection of the protective devices, please take each power cable's current capacity and the system's overload capacity (please refer to **Appendix 1: Technical Specifications**) into consideration. Besides, the short-circuit capacity of the upstream protective device's must be equal to or higher than the capacity of the UPS's protective devices.
- If the UPS is supplied by a power source whose neutral is grounded, the backfeed protective device installed as UPS input protection must be a 3-pole type. If the UPS is supplied by a power source whose neutral is not grounded, the backfeed protective device installed as UPS input protection must be a 4-pole type.
 - The recommended electrical rating of the backfeed protective device is as follows.

15kVA	30kVA	45kVA	60kVA
240V/ 60A	240V/ 125A	240V/ 175A	240V/ 225A

1.3 Usage Warnings

- Before installation, wiring and working on the UPS's internal circuits, please completely cut off all power supplying to the UPS, including the input power and battery power.
- The UPS is specifically designed for information technology equipment and used to power computers, servers, and associated peripheral devices. If you want to connect any capacitive loads or non-linear loads (that have serious surge current) to the UPS, it needs to be de-rated according to on-site applications. For such special applications, please contact Delta service personnel for the accurate UPS sizing. The UPS is not suitable for connecting with any asymmetrical loads. For the load suitability, please contact Delta customer service before purchasing.
- The external slits and openings in the UPS are provided for ventilation. To ensure reliable operation of the UPS and to protect the UPS from overheating, these slits and openings must not be blocked or covered. Do not insert any object into the slits and openings that may hinder ventilation.
- Before applying electrical power to the UPS, you must allow the UPS to adjust to room temperature 68 ~ 77 °F (20 ~ 25°C) for at least one hour to avoid moisture condensing inside the UPS.
- Do not put beverages on the UPS, external battery cabinet or any other accessory associated with the UPS.
- Do not open or remove the covers or panels of the UPS to avoid high voltage electric shock. Only authorized Delta engineers or service personnel can do so for installation or maintenance. If you want to open or remove the covers or panels, do it only under the supervision of authorized Delta engineers or service personnel.
- It is not recommended to connect the UPS to any regenerative loads. For the load suitability, please contact Delta customer service before purchasing.
- The risk of dangerous high voltage is possible when batteries are still connected to the UPS even though the UPS is disconnected from the power sources. Before maintenance, please completely cut off all battery power from the UPS.
- Do not dispose of the battery or batteries in a fire. The batteries may explode.
- Do not open or damage the battery or batteries. The released electrolyte is harmful to the skin and eyes and may be toxic.
- The UPS is electronic equipment that runs 24 hours continuously. To ensure its normal lifetime, regular maintenance of the UPS and batteries is of vital importance and necessary.
- Some components like batteries, power capacitors, and fans will become worn-out due to long-term usage, and this will increase the risk of UPS failure. To replace and maintain the components, please contact Delta service personnel.

- A battery can present a risk of electric shock and high short-circuit current. The following precautions should be observed before replacement of batteries:
 1. Remove watches, rings, or other metal objects.
 2. Use tools with insulated handles.
 3. Wear insulating gloves and boots.
 4. Do not lay tools or metal parts on the top of batteries.
 5. Disconnect the charging source prior to connecting or disconnecting the batteries' terminals.
- You must contact Delta customer service if either of the following events occur:
 1. Liquid is poured or splashed on the UPS.
 2. The UPS does not run normally after carefully following the instructions in this User Manual.

1.4 Storage Warnings

- Use the original packing material to pack the UPS to prevent any possible damage from rodents.
- If the UPS needs to be stored prior to installation, it should be placed in a dry indoor area. The allowable storage temperature is below 158 °F (70 °C) and relative humidity is below 95%.

1.5 Standard Compliance

- UL/ cUL
- FCC Part 15 Class A

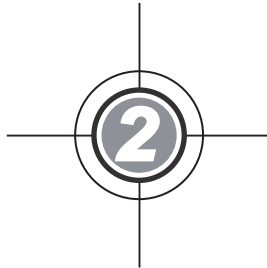

Introduction

- 2.1 General Overview
- 2.2 Package Inspection
- 2.3 Functions & Features
- 2.4 Exterior and Dimensions
- 2.5 Front View
- 2.6 Internal View
- 2.7 Rear View
- 2.8 Tri-color LED Indicator & Buzzer

2.1 General Overview

The DPH series UPS, a three-phase four-wire online uninterruptible power supply, is a dedicated design for data centers and factory facilities. The unit not only adopts advanced IGBT technology to provide high quality, low noise, pure and uninterruptible output power to the connected loads, but also applies the latest design of DSP digital control technology and highest quality components.

The UPS supports high efficient operation modes and its modular and hot-swappable design makes maintenance easy and quick. You can add power modules (optional) according to on-site applications to expand overall system capacity, which realizes a highly cost-effective solution to your power requirements and produces greater electric power efficiency at less cost.

The unit provides diversified communication interfaces for the user to facilitate remote control and management. You can parallel UPS units to increase the system capacity and redundancy and enhance the unit's availability and reliability.

2.2 Package Inspection

- **External**

During UPS transportation, some unpredictable situations might occur. It is recommended that you inspect the UPS exterior packaging. If you notice any damage, please immediately contact the dealer from whom you purchased the unit.

- **Internal**

1. Check the rating label attached to the UPS and make sure the device No. and capacity match what you ordered.
2. Examine if any parts are loose or damaged.
3. The UPS package contains the following items. Please check if any items are missing.

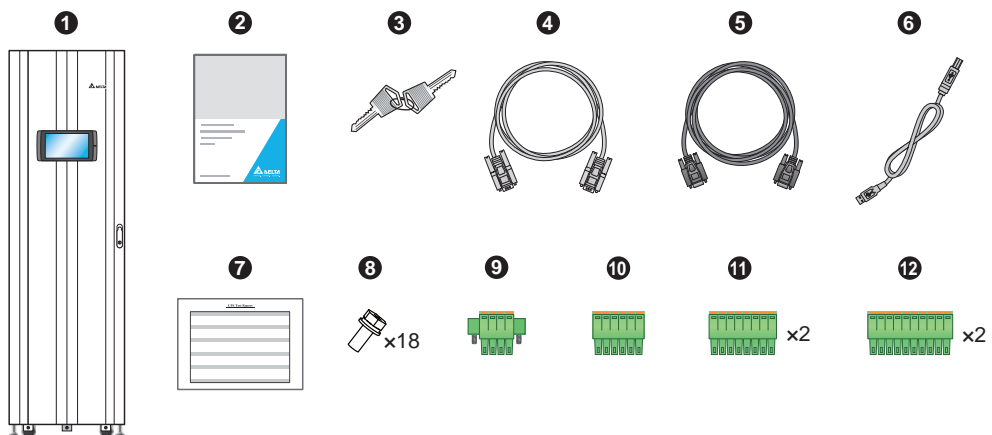

No.	Item	Q'ty
①	UPS (two pieces of 50ppi dust filters have been installed on the inner side of the UPS front door before shipment)	1 PC
②	User Manual	1 PC
③	Key	1 PC (two copies placed inside the UPS cabinet)
④	RS-232 Cable (1.8 meters)	1 PC
⑤	Parallel Cable (3 meters)	1 PC
⑥	USB Cable	1 PC
⑦	Test Report	1 PC
⑧	M8 Screw (used for input/ bypass/ output/ battery/ grounding wiring)	18 PCS
⑨	4-Pin Dry Contact Terminal Block (used for REPO dry contacts; please refer to Figure 4-3)	1 PC
⑩	6-Pin Dry Contact Terminal Block (used for MODBUS and BMS ports located at the rear of the touch panel; please refer to Figure 4-15)	1 PC
⑪	8-Pin Dry Contact Terminal Block (used for (1) external battery temperature dry contacts and (2) external switch/ breaker status dry contacts; please refer to Figure 4-3)	2 PCS
⑫	10-Pin Dry Contact Terminal Block (used for input and output dry contacts; please refer to Figure 4-3)	2 PCS

4. If there is any damage or anything missing, please immediately contact the dealer from whom you purchased the unit.
5. If the UPS needs to be returned, carefully repack the UPS and all of the accessories using the original packing material that came with the unit.

2.3 Functions & Features

- Hot swappable STS module, communication interfaces, power modules (optional) and battery modules (optional) realize on-line maintenance, reduce the MTTR (Mean Time to Repair) and expand system capacity flexibly (15~60kVA).



NOTE:

1. In battery mode, do not hot-swap any battery module.
 2. The battery module is optional. For more information, please refer to **5.9 Battery Module (optional)**.
- Input power factor > 0.99 and input THDi < 3% enhance higher efficiency and diminish power contamination.
 - Output power factor= 1.
 - Efficiency up to 95% saves on operation cost.
 - Automatic input frequency detection enables operation at 50Hz or 60Hz.
 - Automatic restart:
 1. The UPS will restart in online mode automatically right after the AC line resumes following a low battery shutdown.
 2. The UPS returns automatically to online mode from bypass mode after an overload condition is cleared.
 - Automatically detects whether bypass voltage is out of rating voltage (default: voltage $\pm 10\%$ & frequency $\pm 3\text{Hz}$). If yes, the UPS will stop supplying power to the critical loads to protect your electronic equipment.
 - Supports ECO mode: when input voltage and frequency are within the range of rating voltage $\pm 10\%$ and rating frequency $\pm 3\text{Hz}$, the UPS will transfer to bypass mode; otherwise, the UPS will transfer to online mode to reach higher efficiency.
 - Both auxiliary power and control circuit adopt redundancy design, which doubly enhances UPS reliability.
 - Generator compatible
 - Surge protection and EMI filter functions.
 - Remote emergency power off.
 - Single input and dual input functions.
 - Supports external switch/ breaker status detection.

- Wide AC input voltage range (96Vac~146Vac) reduces frequent transfer from online mode to battery mode to save battery consumption and prolong battery life.
- Supports battery-start.
- AC start-up function even when the UPS is not connected to the batteries.

**WARNING:**

Please note that when the UPS is not connected to the batteries, it will not protect your equipment if the utility power is lost.

- Connects at maximum four external battery cabinets to extend backup time.
- Schedulable battery test and battery replacement alarm.
- Battery temperature monitoring and compensation.
- Smart battery charger design allows auto-charging or manual charging to shorten charging time.
- Provides communication interfaces and a smart slot (where you can install the optional Relay I/O card for dry contact expansion. Please refer to **4. Communication Interfaces**).
- Built-in RS-232 port and USB port located on the communication interfaces allow monitoring and management of the UPS. For relevant location and information, please refer to **Figure 4-3** and **Page 4-11**.
- Built-in USB ports () located at the rear of the touch panel allow upgrade of the UPS, touch panel, power modules, system control card and parallel communication cards' firmware and event log download. For relevant location and information, please refer to **Page 4-13** and **Page 4-14**.
- Built-in SRAM records at maximum 10000 event logs.
- 10-inch graphic and color touch panel enables the user to easily operate the UPS and understand the UPS status.
- Fan speed auto adjustment prolongs fan life and reduces noise when the critical loads decrease. Besides, fan failure detection circuit is established.
- State-of-the-art microprocessor technology performs self-detection and monitors fan speed in real time, which provides complete and detailed operating status of the UPS.

2.4 Exterior and Dimensions

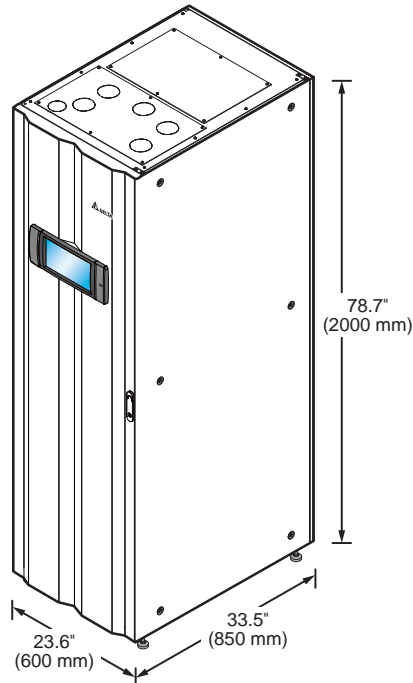

(Figure 2-1: Exterior & Dimensions)

2.5 Front View

On the front of the UPS, there are a 10" color touch panel, a tri-color LED indicator, a door switch, six casters and four leveling feet. Please see **Figure 2-2**.

1. For information about the 10" color touch panel, please refer to **7. LCD Display & Settings**.
2. For information about the tri-color LED indicator, please refer to **2.8 Tri-color LED Indicator & Buzzer**.
3. The casters at the bottom of the UPS can be used to move over short distances, and the leveling feet fix and stabilize the UPS on the ground. Please refer to **5.3 UPS Transportation** for relevant information.
4. Please refer to **Figure 2-3** for how to open the UPS front door.

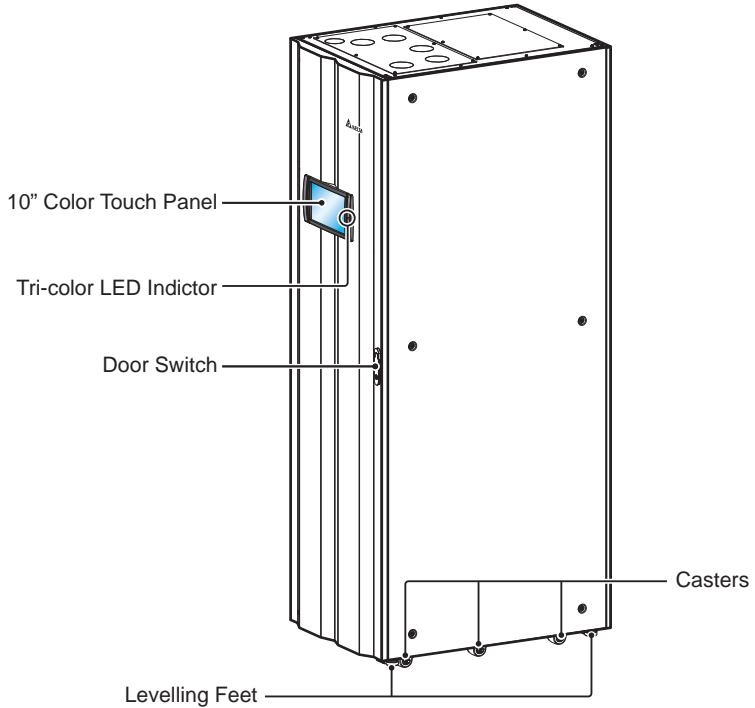

(Figure 2-2: UPS Front View)

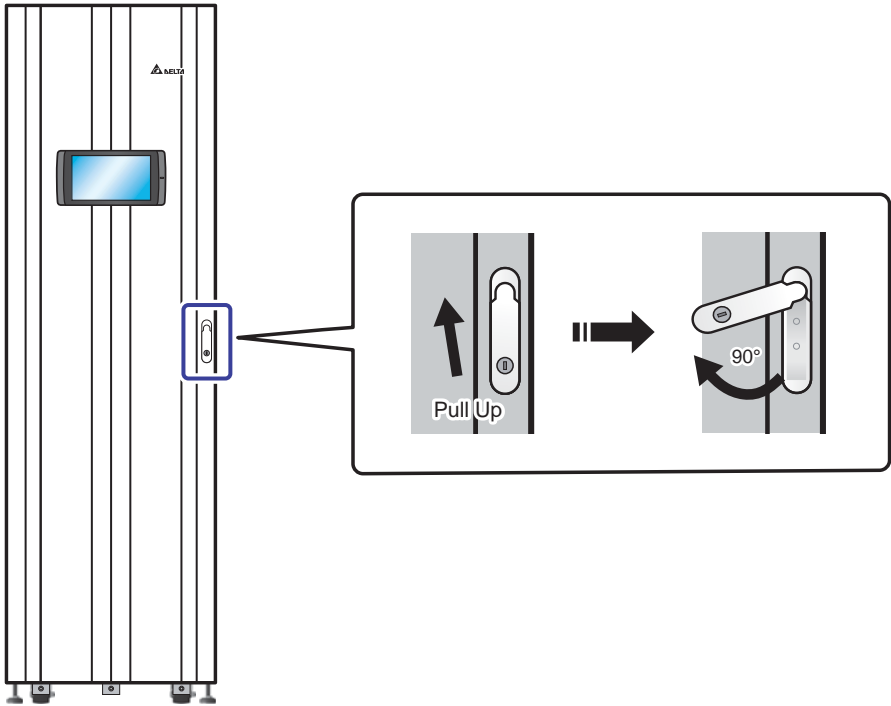

(Figure 2-3: How to Open the UPS Front Door)

2.6 Internal View



WARNING:

Only authorized Delta engineers or service personnel can perform installation, wiring, panel & cover removal, maintenance and operation. If you want to execute any action mentioned above by yourself, the action must be under the supervision of authorized Delta engineers or service personnel.

After you open the UPS's front door, you will see the internal mechanisms including a wiring terminal cover, two communication interfaces, three breakers, an STS module, five power module slots and four battery module slots. Please refer to **Figure 2-4**.

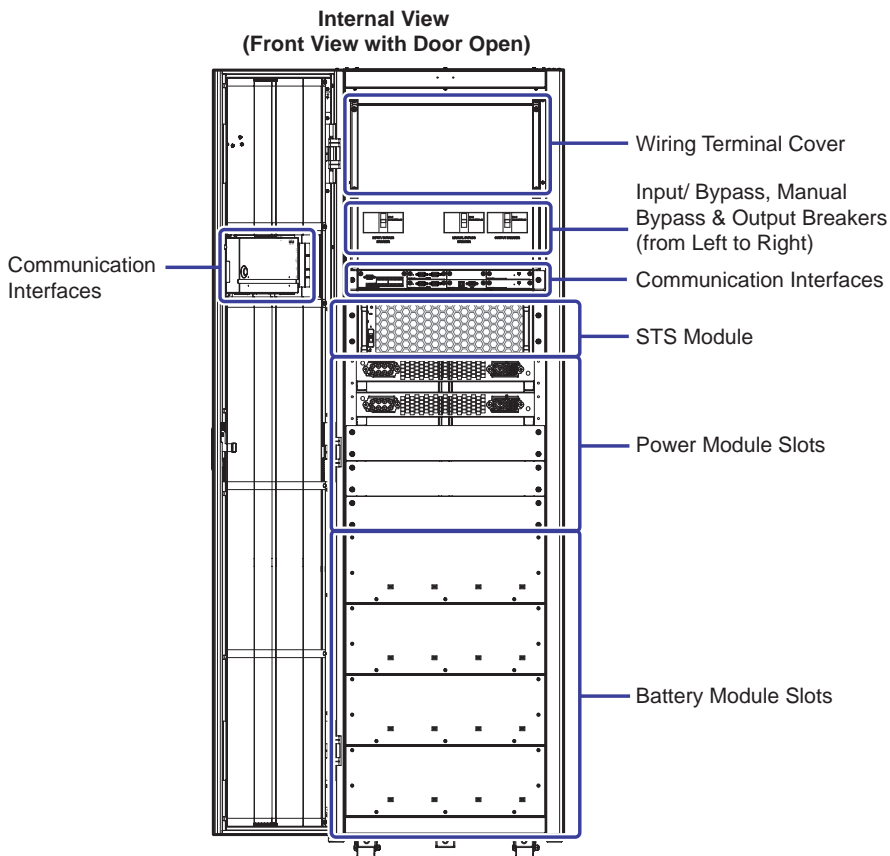

(Figure 2-4: UPS Internal View (Front View with Door Open))

1. For information about the communication interfaces, please refer to **4. Communication Interfaces**.
2. For STS module information, please refer to **5.7 STS Module**.
3. For the power module slots (total: five), please follow on-site requirements to install appropriate number of power modules (optional) into the slots. Please refer to **5.8 Power Module (Optional)** for relevant information.

4. For the battery module slots (total: four), please follow on-site requirements to install appropriate number of battery modules (optional) into the slots. Please refer to **5.9 Battery Module (Optional)** for relevant information.
5. The UPS has three breakers, which are Input/ Bypass, Manual Bypass and Output breakers. Please refer to **Figure 2-5**.

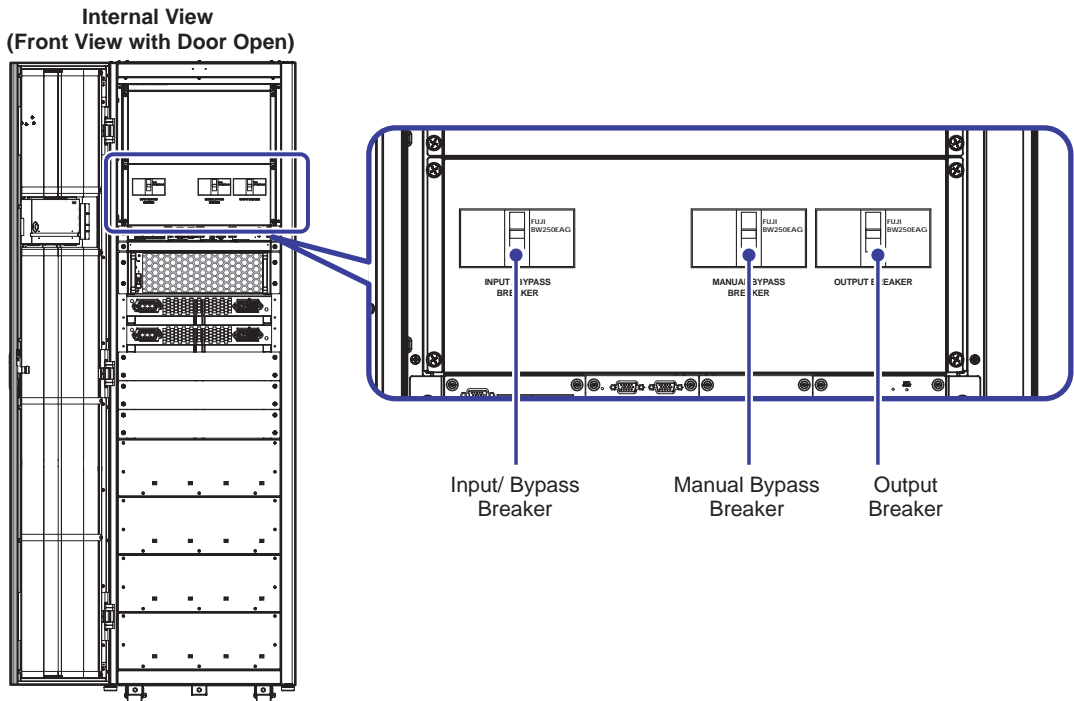

(Figure 2-5: Input/ Bypass, Manual Bypass & Output Breakers)

6. Please remove the wiring terminal cover (there are a total of four screws (see **Figure 2-6**) to see the wiring terminals shown in **Figure 2-7 ~ Figure 2-9**.

Internal View
(Front View with Door Open)

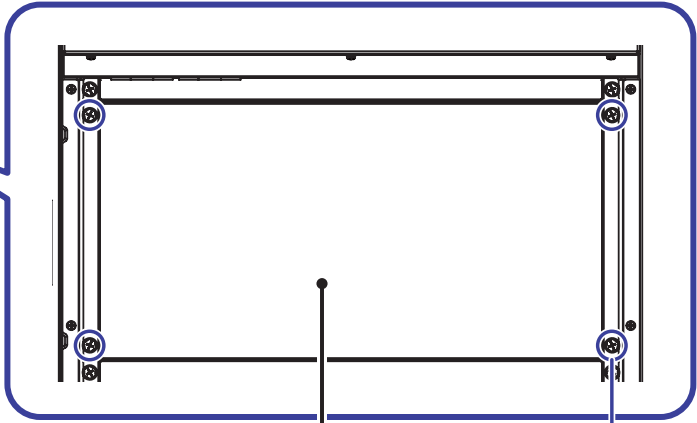
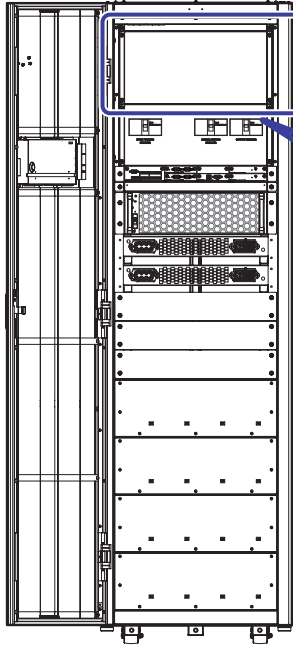

Wiring Terminal Cover

Screw x 4

(Figure 2-6: Wiring Terminal Cover & Screws Location)

(Internal View after Wiring
Terminal Cover Removal)

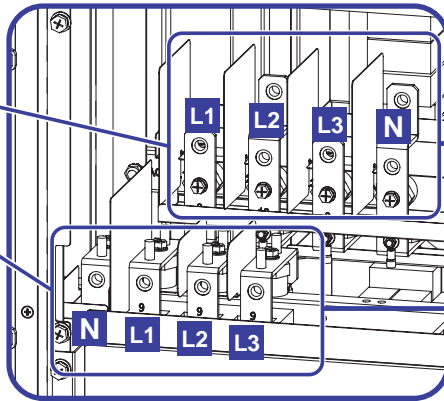
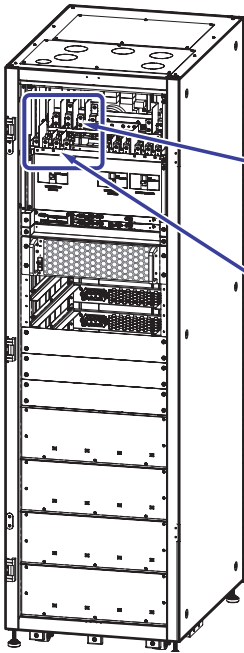

AC Input (for
Dual Input Application)

AC Input (for Single
Input Application)/
Bypass Input (for
Dual Input Application)

(Figure 2-7: Wiring Terminals_ AC Input & Bypass Input)

(Internal View after Wiring
Terminal Cover Removal)

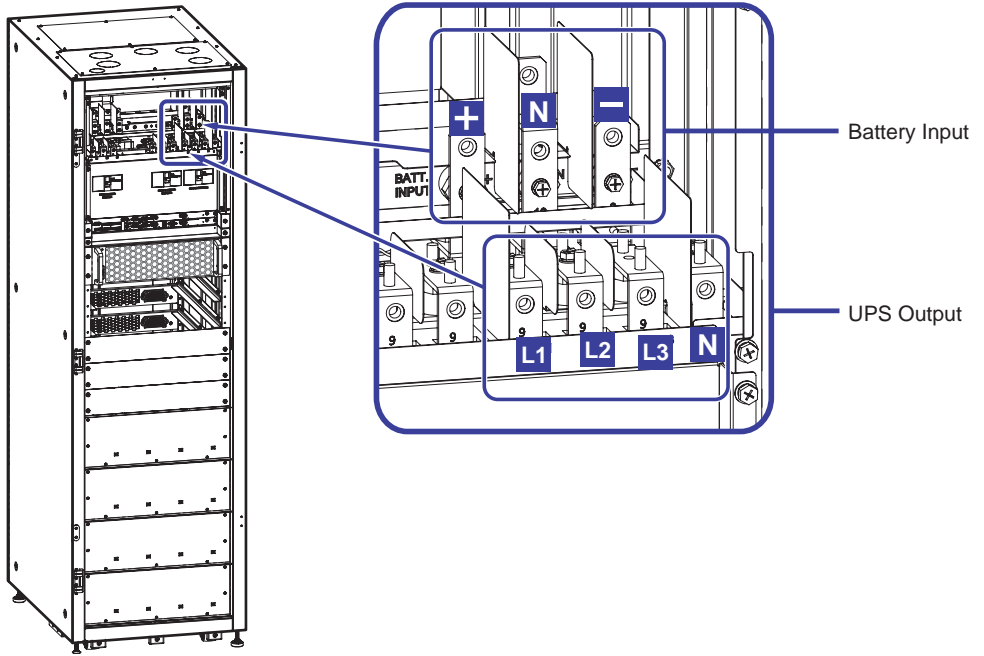

(Figure 2-8: Wiring Terminals_ UPS Output & Battery Input)

(Internal View after Wiring
Terminal Cover Removal)

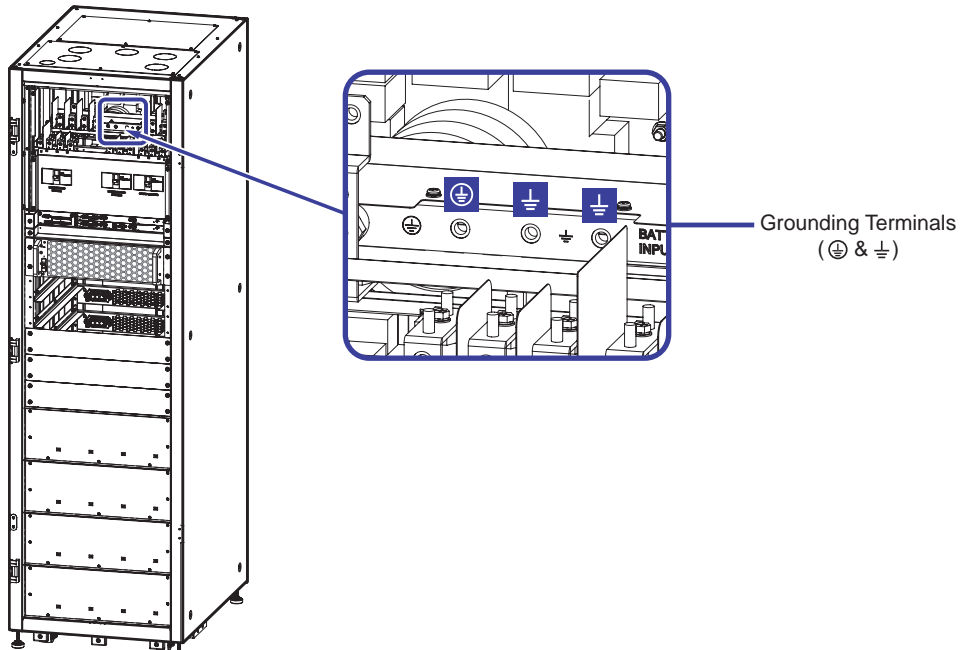

(Figure 2-9: Wiring Terminals_ Grounding)

2.7 Rear View



WARNING:

Only authorized Delta engineers or service personnel can perform installation, wiring, panel & cover removal, maintenance and operation. If you want to execute any action mentioned above by yourself, the action must be under the supervision of authorized Delta engineers or service personnel.

The rear view of the UPS is shown in **Figure 2-10**. There are no user operable or replaceable parts at the rear.

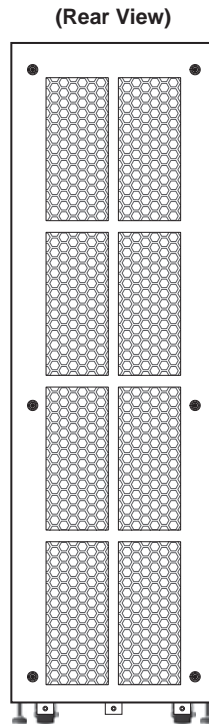

(Figure 2-10: UPS Rear View)

2.8 Tri-color LED Indicator & Buzzer

Please see **Figure 2-11** for the location of the tri-color LED indicator. For information about the tri-color LED indicator, please refer to **Table 2-1**. For information about the 10" color touch panel, please refer to **7. LCD Display and Settings**.



(Figure 2-11: Tri-color LED Indicator Location)

Open the UPS front door and find the buzzer at the rear of the UPS front door. Please see **Figure 2-12**.

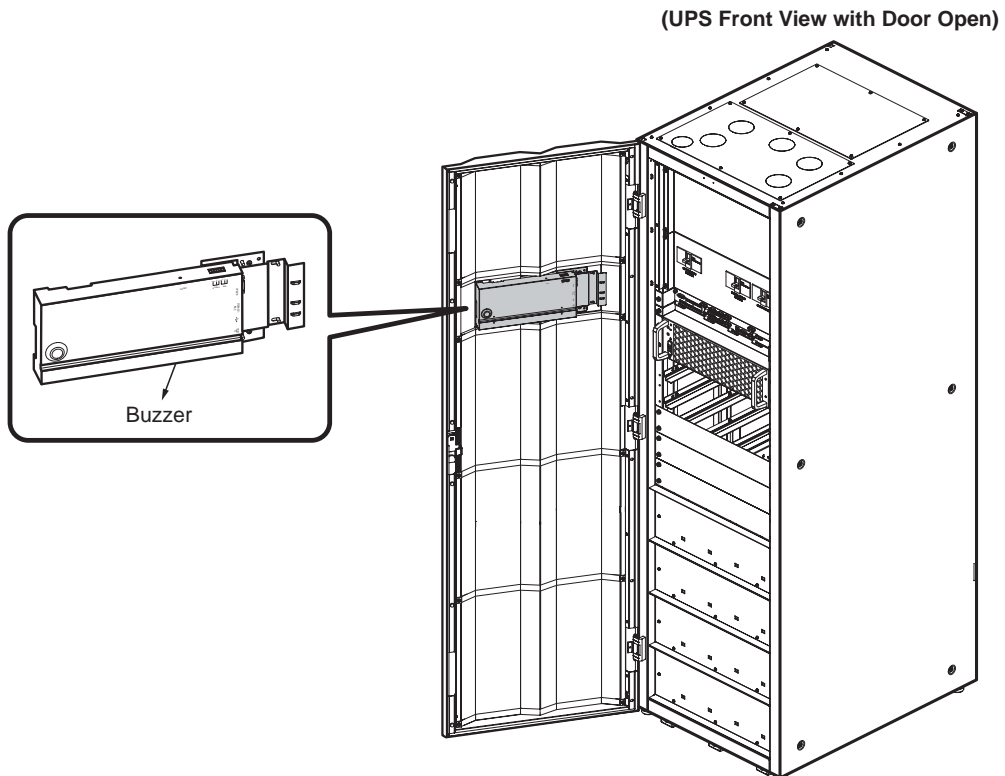

(Figure 2-12: Buzzer Location)

Please refer to the table below for the status of the tri-color LED indicator and buzzer.

Table 2-1: Tri-color LED Indicator & Buzzer

Tri-color LED Indicator	Status	Meaning						
Green	ON	<ol style="list-style-type: none"> 1. The UPS is running in online mode and the text 'On-Line' appears in the upper right corner of the screen. 2. The UPS is running in ECO mode and the text 'ECO' appears in the upper right corner of the screen. 3. The UPS is running in frequency conversion mode and the text 'Frequency Conversion' appears in the upper right corner of the screen. 4. The UPS is running in green mode and the text 'Green' appears in the upper right corner of the screen. 						
Yellow	ON	<ol style="list-style-type: none"> 1. The UPS is running in bypass mode and the text 'Bypass' appears in the upper right corner of the screen. 2. The UPS is running in battery mode and the text 'Battery' appears in the upper right corner of the screen. 3. The UPS is running in standby mode and the text 'Standby' appears in the upper right corner of the screen. 4. The UPS is in the soft start status and the text 'Softstart' appears in the upper right corner of the screen. 5. The UPS is in the energy recycle status and the text 'Energy Recycle' appears in the upper right corner of the screen. 6. There is a minor or medium warning and the buzzer sounds. <table border="1" data-bbox="557 1176 1192 1383"> <thead> <tr> <th data-bbox="557 1176 765 1232">Warning Level</th> <th data-bbox="765 1176 1192 1232">Buzzer Frequency</th> </tr> </thead> <tbody> <tr> <td data-bbox="557 1232 765 1307">Minor</td> <td data-bbox="765 1232 1192 1307">The buzzer beeps 0.5 second for every three seconds.</td> </tr> <tr> <td data-bbox="557 1307 765 1383">Medium</td> <td data-bbox="765 1307 1192 1383">The buzzer beeps 0.5 second for every second.</td> </tr> </tbody> </table> <p data-bbox="518 1398 1177 1427">To clear the warning, please refer to 10. Troubleshooting.</p>	Warning Level	Buzzer Frequency	Minor	The buzzer beeps 0.5 second for every three seconds.	Medium	The buzzer beeps 0.5 second for every second.
Warning Level	Buzzer Frequency							
Minor	The buzzer beeps 0.5 second for every three seconds.							
Medium	The buzzer beeps 0.5 second for every second.							
Red	ON	<p data-bbox="518 1450 1067 1479">There is a major warning and the buzzer sounds.</p> <table border="1" data-bbox="557 1493 1192 1590"> <thead> <tr> <th data-bbox="557 1493 765 1549">Warning Level</th> <th data-bbox="765 1493 1192 1549">Buzzer Frequency</th> </tr> </thead> <tbody> <tr> <td data-bbox="557 1549 765 1590">Major</td> <td data-bbox="765 1549 1192 1590">Long beep</td> </tr> </tbody> </table> <p data-bbox="518 1605 1177 1634">To clear the warning, please refer to 10. Troubleshooting.</p>	Warning Level	Buzzer Frequency	Major	Long beep		
Warning Level	Buzzer Frequency							
Major	Long beep							

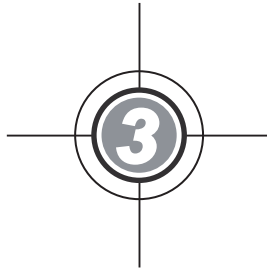

Operation Modes

- 3.1 Single Input
- 3.2 Dual Input
- 3.3 Hot Standby Redundancy
(Only for Dual Input & at
Least Two UPSs)
- 3.4 Common Battery (Only for
Parallel UPSs Connecting
to the Same External
Battery Cabinet(s))

The UPS runs in eight basic operation modes, which are online mode, battery mode, bypass mode, manual bypass mode, ECO mode, frequency conversion mode, green mode and energy recycle mode. Besides these eight operation modes, the UPS is also designed for common battery application and hot standby redundancy. Please see the following sections for relevant information.



NOTE:

1. In this user manual, the meaning of Q1, Q2 and Q3 represents the following.

Code	Meaning
Q1	Input/ Bypass Breaker
Q2	Manual Bypass Breaker
Q3	Output Breaker

2. Only UPSs with the same capacity, voltage and frequency can be paralleled. Please only use the provided parallel cable to parallel the UPS units; otherwise, parallel functions will fail. For UPS parallel information and application, please contact Delta service personnel.

3.1 Single Input

3.1.1 Online Mode_ Single Input_ Single Unit

In online mode, the main AC source supplies AC power via the Input/ Bypass Breaker (Q1) to the rectifier, and the rectifier converts the AC power to DC power and supplies the DC power to the inverter. In the meantime, the rectifier provides charging power to the batteries. After receiving the DC power, the inverter converts it into clean and stable AC power to the connected critical loads via the Output Breaker (Q3). Please refer to **Figure 3-1**. During online mode, the UPS’s tri-color LED illuminates green and the text ‘On-Line’ appears in the upper right corner of the screen.

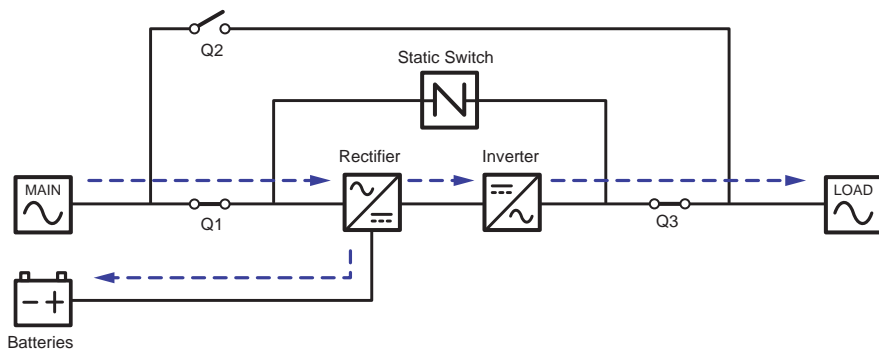

(Figure 3-1: Online Mode Diagram_ Single Input Single Unit)

3.1.2 Battery Mode_ Single Input_ Single Unit

The UPS transfers to battery mode automatically if the main AC source cannot supply power, for example, when unstable voltage or a power outage occurs. In battery mode, the batteries provide DC power and the UPS converts it into AC power and supplies it to the connected critical loads via the Output Breaker (Q3). During the conversion process, output voltage remains the same. Please see **Figure 3-2**. During battery mode, the UPS's tri-color LED illuminates yellow and the text 'Battery' appears in the upper right corner of the screen.

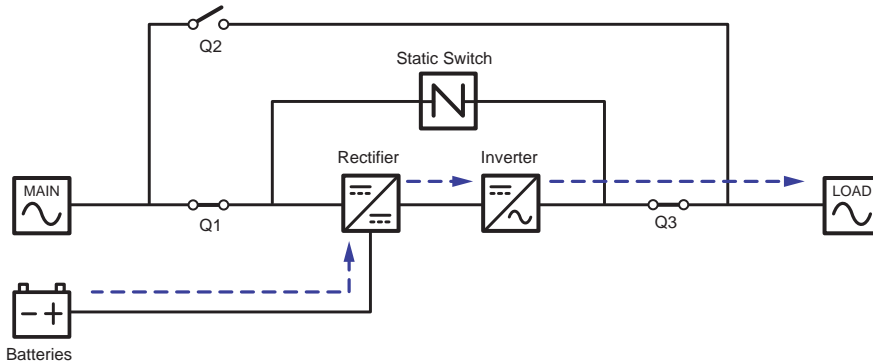

(Figure 3-2: Battery Mode Diagram_ Single Input Single Unit)

3.1.3 Bypass Mode_ Single Input_ Single Unit

When the inverter encounters abnormal situations such as over temperature, overload, short circuit, abnormal output voltage or low battery, it will automatically shut itself down. If the UPS detects the bypass AC source is normal, it will automatically switch to bypass mode to protect the connected critical loads from power interruption. Please refer to **Figure 3-3**. After the above-mentioned abnormalities are eliminated, the UPS will switch back to online mode from bypass mode. During bypass mode, the UPS's tri-color LED illuminates yellow and the text 'Bypass' appears in the upper right corner of the screen.

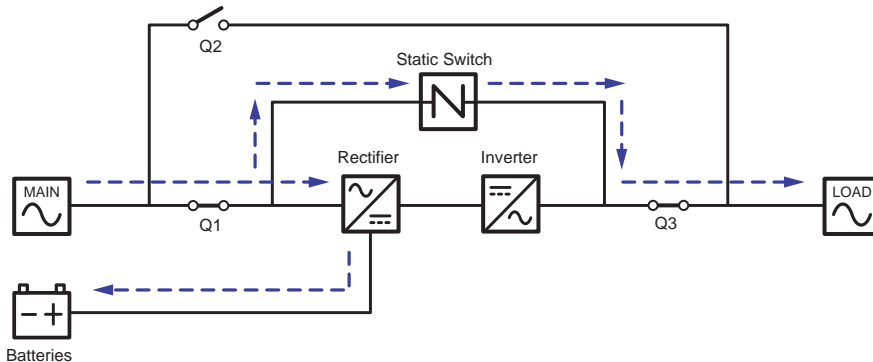

(Figure 3-3: Bypass Mode Diagram_ Single Input Single Unit)

3.1.4 Manual Bypass Mode_ Single Input_ Single Unit

When the UPS needs maintenance, you can manually switch the UPS to manual bypass mode. To let the UPS run in manual bypass mode, please follow the procedures below:

- 1 Confirm that the bypass AC source and the STS module are normal.
- 2 Press the LCD's ON/ OFF button (🔌) once and the 'POWER OFF?' screen will pop up to ask you if you want to power off the inverter. Please select 'YES'.
- 3 Turn on the Manual Bypass Breaker (Q2).
- 4 Turn off the Input/ Bypass Breaker (Q1) and Output Breaker (Q3).
- 5 Turn off each external battery cabinet's breaker and take out every battery module (optional) from the UPS's battery module slot. For the battery module slot's location, please refer to **2.6 Internal View**. For battery module (optional) information, please refer to **5.9 Battery Module (Optional)**. For external battery cabinet information, please refer to **5.6 External Battery Cabinet Connection Warnings**.

In manual bypass mode, all power inside the UPS is completely cut off and maintenance personnel can perform maintenance safely. For manual bypass mode diagram, please see **Figure 3-4**. During manual bypass mode, the UPS's tri-color LED and LCD are both off.



WARNING:

1. In manual bypass mode, make sure that all of the breakers and switches (except the Manual Bypass Breaker (Q2)) are in the **OFF** position before working on the UPS's internal circuits. This avoids electric shock.
2. After the power inside the UPS is completely cut off, there is no high voltage inside the UPS except the wiring terminals and the Manual Bypass Breaker (Q2). Do not touch the wiring terminals and the Manual Bypass Breaker (Q2) during UPS maintenance process to avoid electric shock.
3. During manual bypass mode, the UPS's input power is completely cut off and the connected critical loads are not protected.

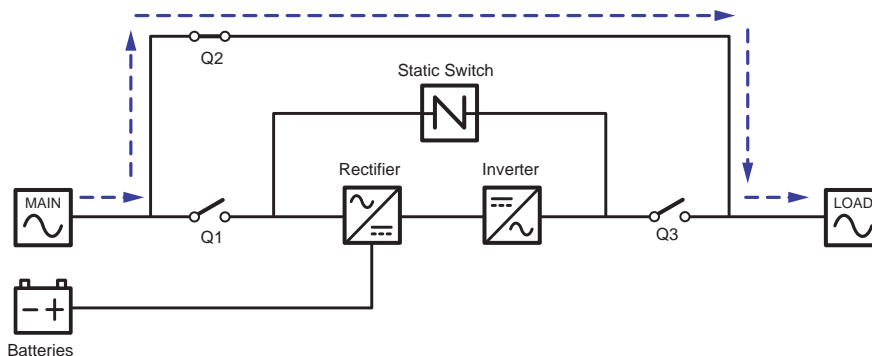

(Figure 3-4: Manual Bypass Mode Diagram_ Single Input Single Unit)

3.1.5 ECO Mode_ Single Input_ Single Unit

To activate ECO mode, please refer to **6.2.5 ECO Mode Start-up Procedures**, **7.6 Main Screen** and **7.10.2 Mode Setting**.

In ECO mode, when the bypass AC source's input voltage and frequency are within the range of rating voltage $\pm 10\%$ and rating frequency $\pm 3\text{Hz}$, the UPS works in bypass mode; otherwise, the UPS runs in online mode. For ECO mode diagram, please see **Figure 3-5**. During ECO mode, the UPS's tri-color LED illuminates green and the text 'ECO' appears in the upper right corner of the screen.

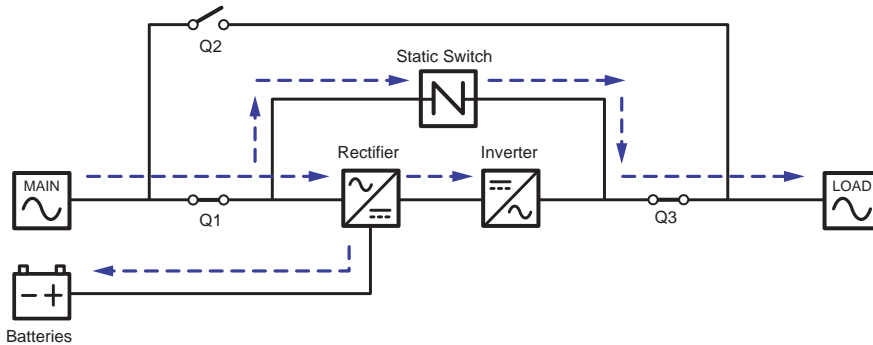

(Figure 3-5: ECO Mode Diagram_ Single Input Single Unit)

3.1.6 Frequency Conversion Mode_ Single Input_ Single Unit

To activate frequency conversion mode, please refer to **6.2.6 Frequency Conversion Mode Start-up Procedures**, **7.6 Main Screen** and **7.10.2 Mode Setting**.

After the UPS is manually set in frequency conversion mode, the inverter will automatically select 50Hz or 60Hz as the fixed output frequency. After the output frequency is determined, the system will automatically disable the bypass function. Please note that, once the inverter shuts down, there is no bypass output. For the diagram of frequency conversion mode, please see **Figure 3-6**. During frequency conversion mode, the UPS's tri-color LED illuminates green and the text 'Frequency Conversion' appears in the upper right corner of the screen.

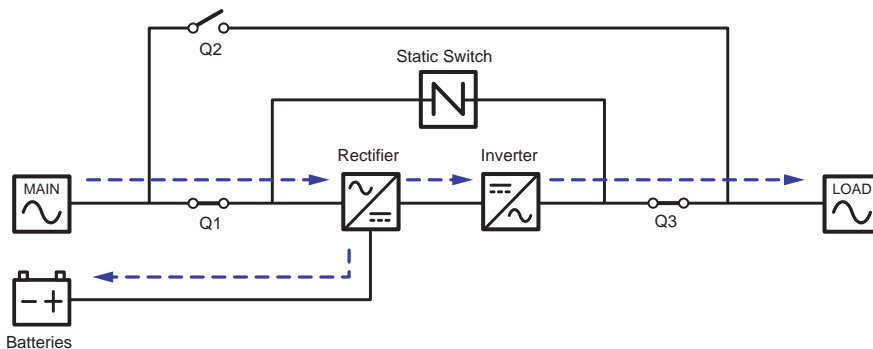

(Figure 3-6: Frequency Conversion Mode Diagram_ Single Input Single Unit)



NOTE: During frequency conversion mode, once the inverter shuts down, there is no bypass output.

3.1.7 Green Mode_ Single Input_ Single Unit

To activate green mode, please refer to **6.2.7 Green Mode Start-up Procedures**, **7.6 Main Screen** and **7.10.2 Mode Setting**.

Green mode is the same as online mode, but the difference is that the system will automatically detect the output status (i.e. total load capacity %) to decide which specific power modules should be fully powered on or idle in order to achieve higher efficiency of the UPS. For the green mode diagram, please see **Figure 3-7**. During green mode, the UPS's tri-color LED illuminates green and the text 'Green' appears in the upper right corner of the screen.

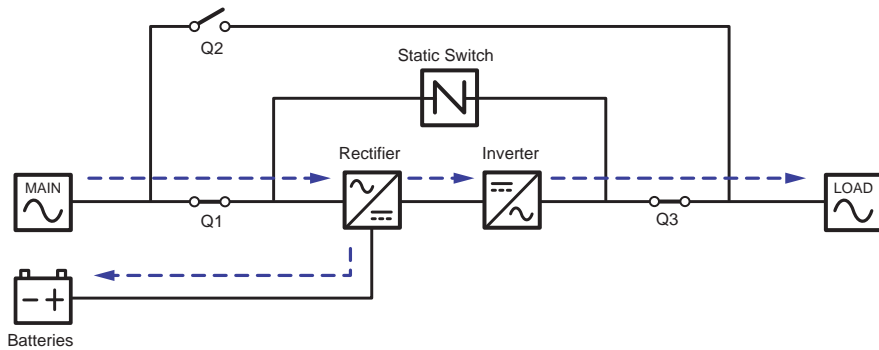

(Figure 3-7: Green Mode Diagram_ Single Input Single Unit)

3.1.8 Energy Recycle Mode_ Single Input_ Single Unit



NOTE: Energy recycle mode is only applicable to single input and single unit application.

Energy recycle mode is only applicable to UPS self-test only. Without connection of any critical loads, the UPS can execute current test under full load condition. Before you activate energy recycle mode, please make sure that the Manual Bypass Breaker (Q2) and Output Breaker (Q3) are in the **OFF** status.

To activate energy recycle mode (only qualified service personnel can do so), please refer to **6.2.8 Energy Recycle Mode Start-up Procedures**, **7.6 Main Screen** and **7.10.2 Mode Setting**.

For the diagram of energy recycle mode, please see **Figure 3-8**. During energy recycle mode, the UPS's tri-color LED illuminates yellow and the text 'Energy Recycle' appears in the upper right corner of the screen.

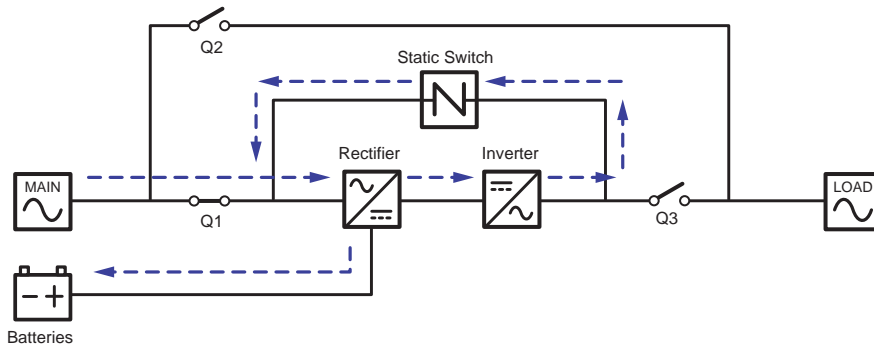

(Figure 3-8: Energy Recycle Mode Diagram_ Single Input Single Unit)

3.1.9 Online Mode_ Single Input_ Parallel Units

In online mode (parallel), the total loads will be equally shared by the parallel UPSs. If one of the parallel units fails and its load is less than the total capacity of the remaining parallel unit, the failing UPS's output will be switched off and its load will be shared by the remaining parallel unit. If the failing UPS's load is larger than the total capacity of the remaining parallel unit, all UPSs' inverters will turn off and the total loads will be supplied by the bypass power. During online mode, each UPS's tri-color LED illuminates green and each UPS's LCD shows the text 'On-Line' in the upper right corner. Please refer to **Figure 3-9** for the path of electrical power through the parallel UPSs in online mode.

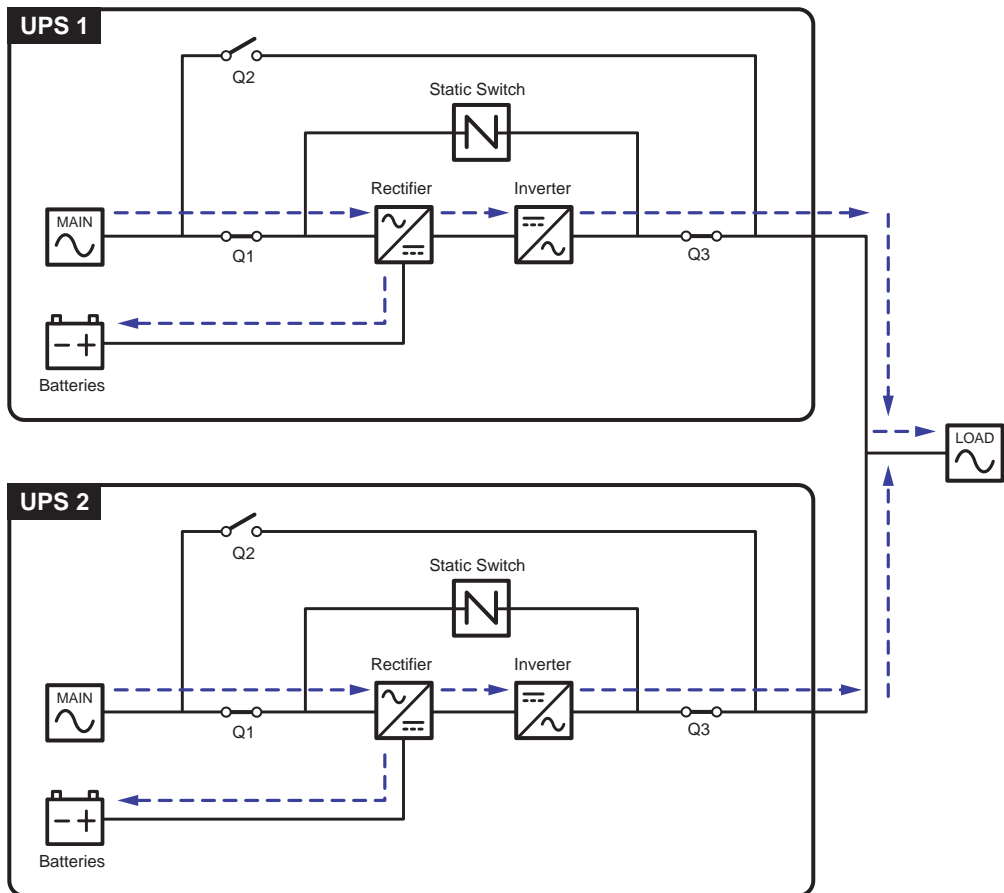

(Figure 3-9: Online Mode Diagram_ Single Input Parallel Units)

3.1.10 Battery Mode_ Single Input_ Parallel Units

If the main AC source cannot supply power, for example, when unstable voltage or a power outage occurs, all parallel UPSs will automatically transfer from online mode to battery mode. During the conversion process, output voltage remains the same, and during battery mode, each UPS's tri-color LED illuminates yellow and each UPS's LCD shows the text 'Battery' in the upper right corner. Please refer to **Figure 3-10** for the path of electrical power through the parallel UPSs in battery mode.

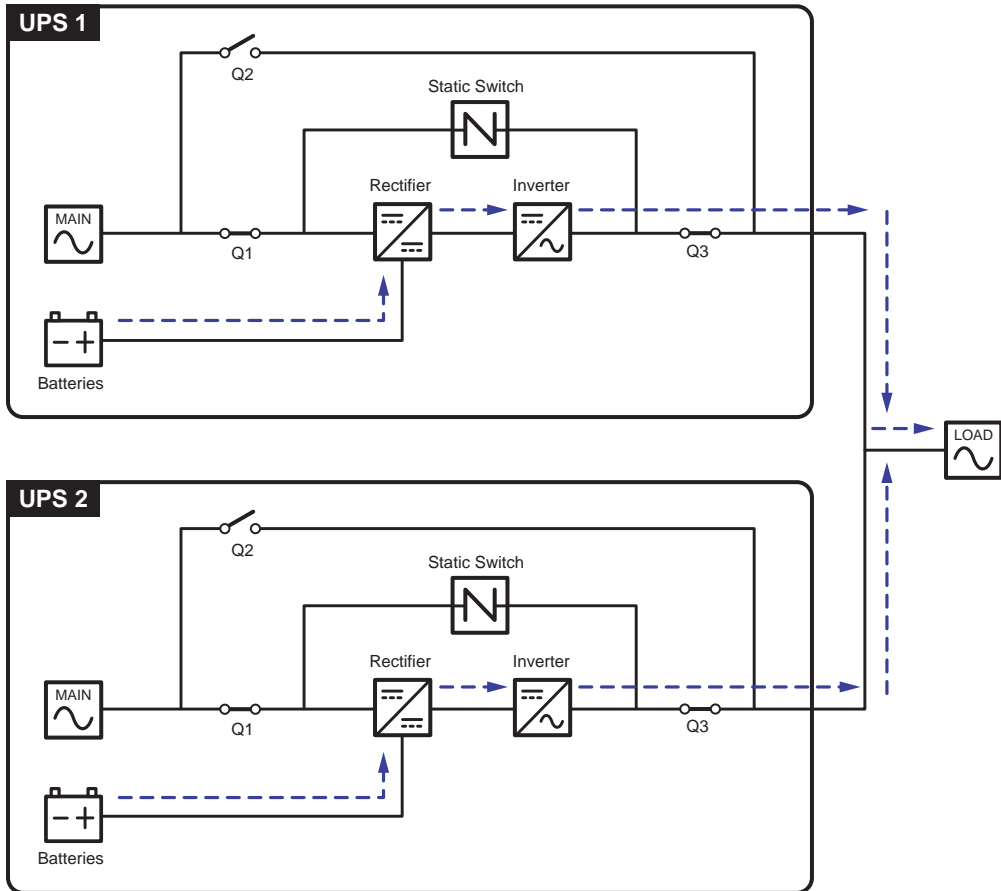

(Figure 3-10: Battery Mode Diagram_ Single Input Parallel Units)

3.1.11 Bypass Mode_ Single Input_ Parallel Units

In parallel mode, when all inverters encounter abnormal situations such as overload, short circuit, abnormal output voltage or low battery, they will automatically shut themselves down. Meanwhile, if all UPSs detect the bypass AC source is normal, they will automatically switch to bypass mode to protect the connected critical loads from power interruption. The critical loads will be equally shared by all parallel units. After the abnormalities mentioned above are eliminated, the UPSs will switch back to online mode from bypass mode. During bypass mode, each UPS's tri-color LED illuminates yellow and each UPS's LCD shows the text 'Bypass' in the upper right corner. Please see **Figure 3-11** for the path of electrical power through the parallel UPSs in bypass mode.

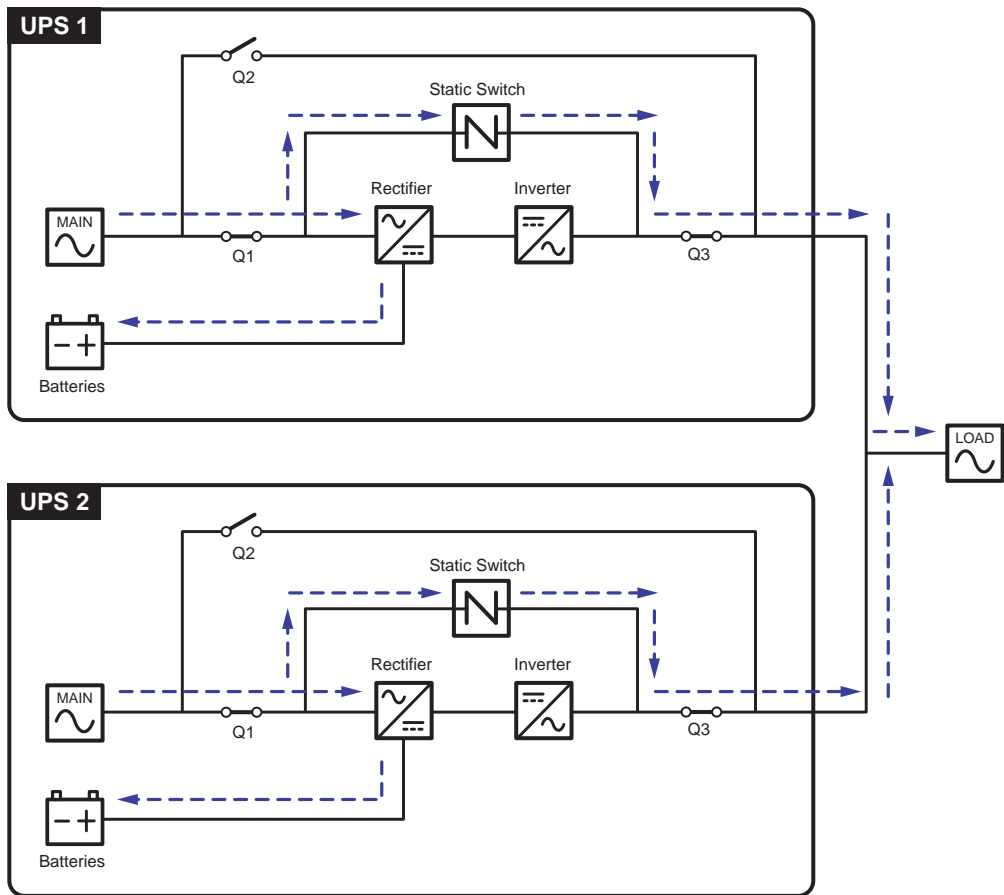

(Figure 3-11: Bypass Mode Diagram_ Single Input Parallel Units)

3.1.12 Manual Bypass Mode_ Single Input_ Parallel Units

In parallel mode, if one of the parallel UPSs needs maintenance, please first confirm that the bypass AC source and each parallel UPS's STS module are normal. After confirmation, please follow the procedures below to manually switch each of the parallel UPSs to manual bypass mode.

- 1 Press each LCD's ON/ OFF button () once and the 'POWER OFF?' screen will pop up to ask you if you want to power off the inverter. Please select 'YES'.
- 2 Turn on each UPS's Manual Bypass Breaker (Q2).
- 3 Turn off each UPS's Input/ Bypass Breaker (Q1) and Output Breaker (Q3).
- 4 Turn off each external battery cabinet's breaker and take out every battery module (optional) from each parallel UPS's battery module slot. For the battery module slot's location, please refer to **2.6 Internal View**. For battery module (optional) information, please refer to **5.9 Battery Module (Optional)**. For external battery cabinet information, please refer to **5.6 External Battery Cabinet Connection Warnings**.

In manual bypass mode, all power inside the parallel UPSs is completely cut off and maintenance personnel can perform maintenance safely. The connected critical loads will be supplied by the manual bypass. During manual bypass mode, all parallel UPSs' tri-color LEDs and LCDs are off. Please see **Figure 3-12** for the path of electrical power through the parallel UPSs in manual bypass mode.



WARNING:

1. In manual bypass mode, make sure that all of the breakers and switches (except each parallel UPS's Manual Bypass Breaker (Q2)) are in the OFF position before working on any of the parallel UPSs' internal circuits. This avoids electric shock.
2. After the power inside all parallel UPSs is completely cut off, there is no high voltage inside the parallel UPSs except each UPS's wiring terminals and Manual Bypass Breaker (Q2). Do not touch each UPS's wiring terminals and Manual Bypass Breaker (Q2) during UPS maintenance process to avoid electric shock.
3. During manual bypass mode, each parallel UPS's input power is completely cut off and the connected critical loads are not protected.



NOTE:

For parallel UPSs, if you want to turn off one of the parallel UPSs for maintenance, please make sure the connected critical loads will not exceed the remaining parallel unit's total capacity.

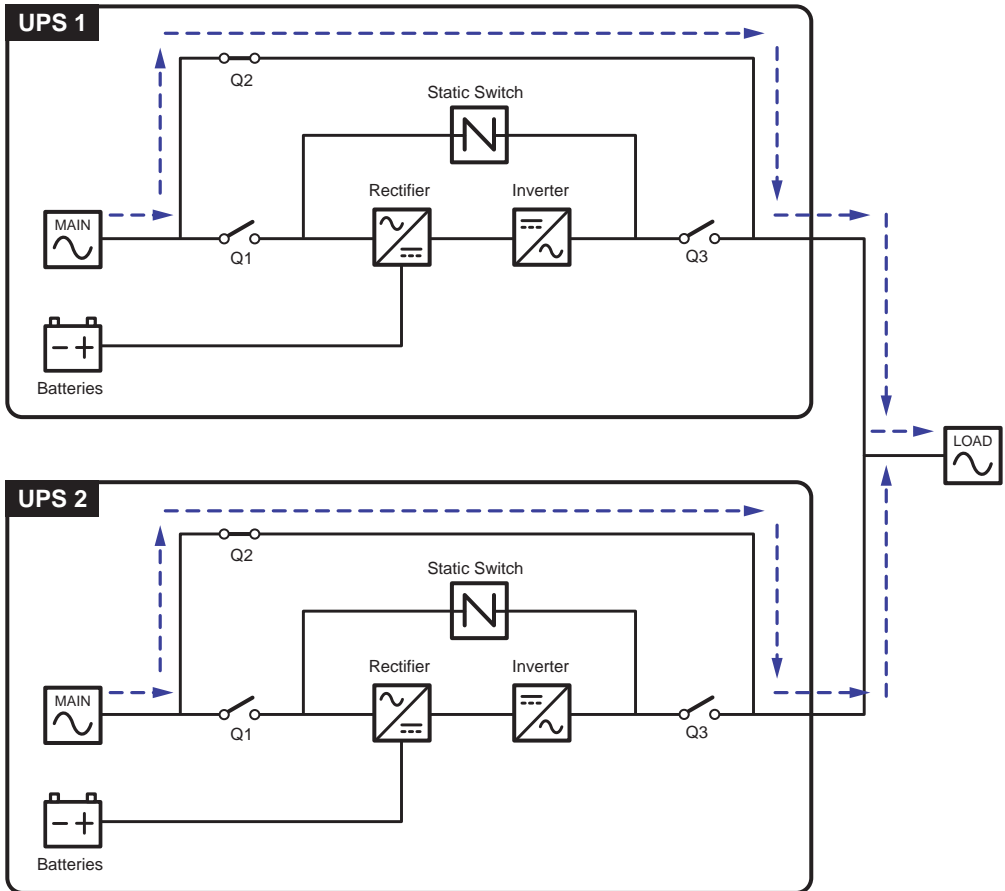

(Figure 3-12: Manual Bypass Mode Diagram_ Single Input Parallel Units)

3.1.13 ECO Mode_ Single Input_ Parallel Units

To activate ECO mode, please refer to **6.2.5 ECO Mode Start-up Procedures**, **7.6 Main Screen** and **7.10.2 Mode Setting**.

In ECO mode (parallel), when each UPS's bypass input voltage and frequency are within the range of rating voltage $\pm 10\%$ and rating frequency $\pm 3\text{Hz}$, each UPS works in bypass mode; otherwise, each UPS runs in online mode. During ECO mode, each UPS's tri-color LED illuminates green and each UPS's LCD shows the text 'ECO' in the upper right corner. Please see **Figure 3-13** for the path of electrical power through the parallel UPSs in ECO mode.

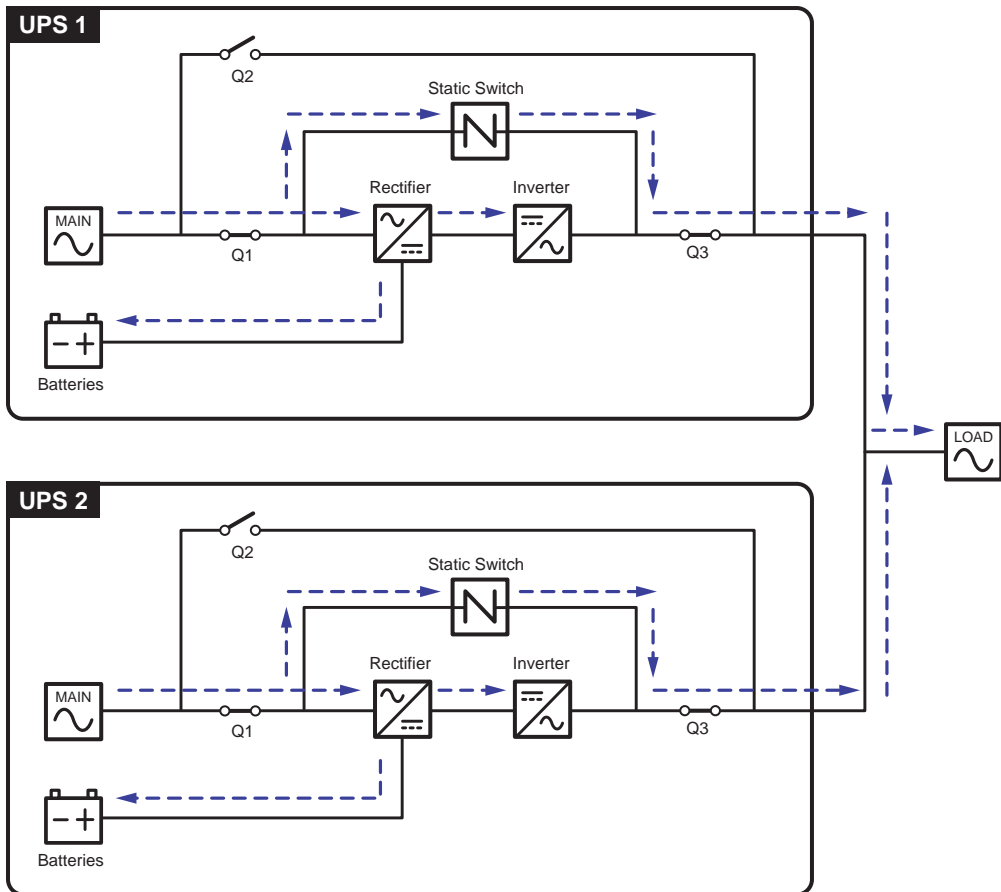

(Figure 3-13: ECO Mode Diagram_ Single Input Parallel Units)

3.1.14 Frequency Conversion Mode_ Single Input_ Parallel Units

To activate frequency conversion mode, please refer to **6.2.6 Frequency Conversion Mode Start-up Procedures**, **7.6 Main Screen** and **7.10.2 Mode Setting**.

For parallel application, after each of the parallel UPSs is manually set in frequency conversion mode, each inverter will automatically select 50Hz or 60Hz as the fixed output frequency. After the output frequency is determined, each system will automatically disable the bypass function. Please note that, once each inverter shuts down, there is no bypass output. During frequency conversion mode, each UPS's tri-color LED illuminates green and each UPS's LCD shows the text **'Frequency Conversion'** in the upper right corner. Please see **Figure 3-14** for the path of electrical power through the parallel UPSs in frequency conversion mode.



NOTE: During frequency conversion mode (parallel), once all of the UPSs' inverters shut down, there is no bypass output.

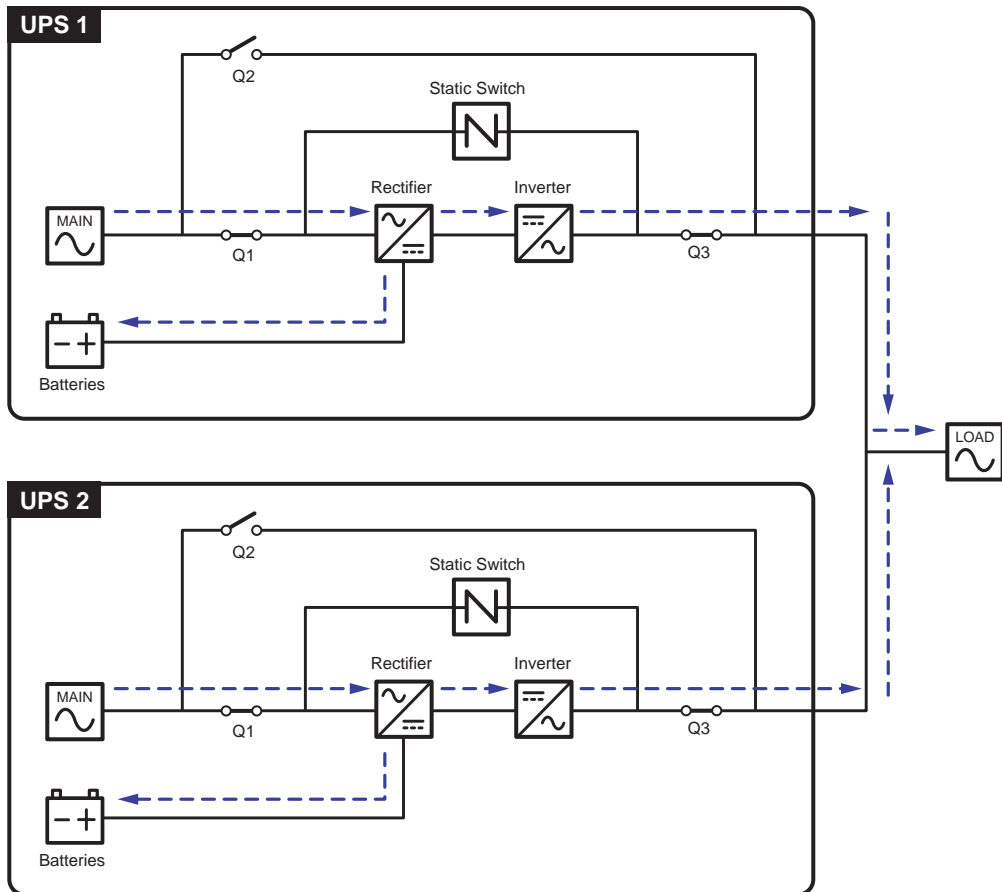

(Figure 3-14: Frequency Conversion Mode Diagram_ Single Input Parallel Units)

3.2 Dual Input

3.2.1 Online Mode_ Dual Input_ Single Unit

In online mode, the main AC source supplies AC power to the rectifier, and the rectifier converts the AC power to DC power and supplies the DC power to the inverter. In the meantime, the rectifier provides charging power to the batteries. After receiving the DC power, the inverter converts it into clean and stable AC power to the connected critical loads via the Output Breaker (Q3). Please see **Figure 3-15** for online mode diagram. During online mode, the UPS's tri-color LED illuminates green and the text 'On-Line' appears in the upper right corner of the screen.

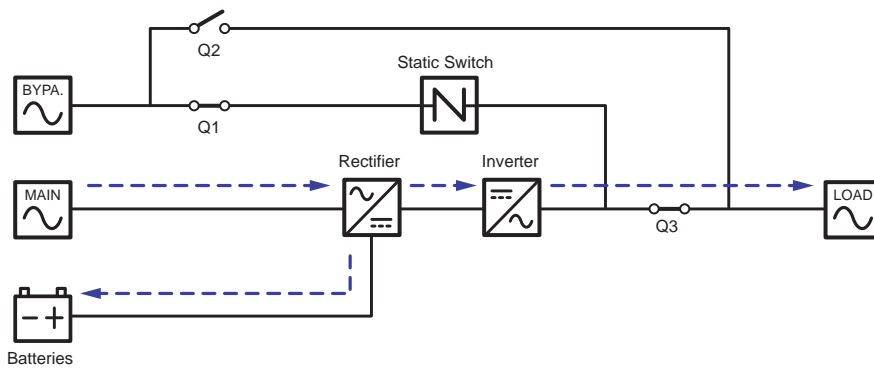

(Figure 3-15: Online Mode Diagram_ Dual Input Single Unit)

3.2.2 Battery Mode_ Dual Input_ Single Unit

The UPS transfers to battery mode automatically if the main AC source cannot supply power, for example, when unstable voltage or a power outage occurs. In battery mode, the batteries provide DC power and the UPS converts it into AC power and supplies it to the connected critical loads via the Output Breaker (Q3). During the conversion process, output voltage remains the same. Please see **Figure 3-16** for battery mode diagram. During battery mode, the UPS's tri-color LED illuminates yellow and the text 'Battery' appears in the upper right corner of the screen.

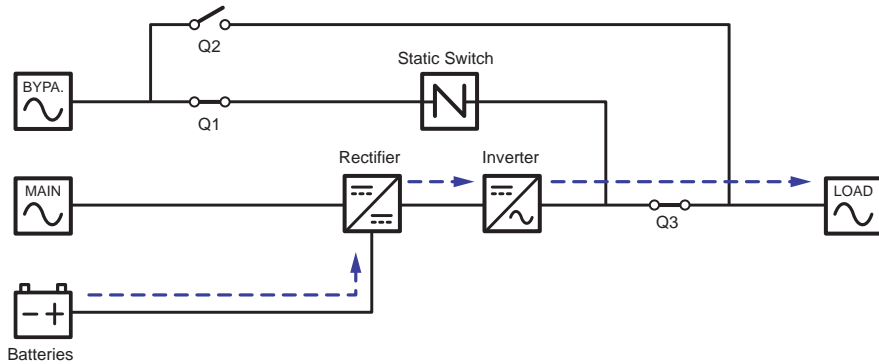

(Figure 3-16: Battery Mode Diagram_Dual Input Single Unit)

3.2.3 Bypass Mode_Dual Input_Single Unit

When the inverter encounters abnormal situations such as over temperature, overload, short circuit, abnormal output voltage or low battery, it will automatically shut itself down. If the UPS detects the bypass AC source is normal, it will automatically switch to bypass mode to protect the connected critical loads from power interruption. Please refer to **Figure 3-17**. After the above-mentioned abnormalities are eliminated, the UPS will switch back to online mode from bypass mode. During bypass mode, the UPS's tri-color LED illuminates yellow and the text 'Bypass' appears in the upper right corner of the screen.

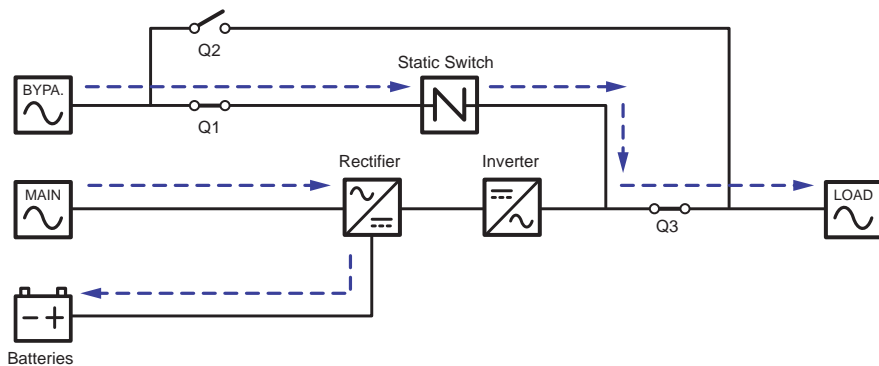

(Figure 3-17: Bypass Mode Diagram_Dual Input Single Unit)

3.2.4 Manual Bypass Mode_ Dual Input_ Single Unit

When the UPS needs maintenance, you can manually switch the UPS to manual bypass mode. To let the UPS run in manual bypass mode, please follow the procedures below:

- 1) Confirm that the bypass AC source and the STS module are normal.
- 2) Press the LCD's ON/ OFF button (🔌) once and the 'POWER OFF?' screen will pop up to ask you if you want to power off the inverter. Please select 'YES'.
- 3) Turn on the Manual Bypass Breaker (Q2).
- 4) If the end user installs an additional Input Breaker to control the ON/ OFF status of the main AC power, please turn the user-supplied Input Breaker off.
- 5) Ensure that the main AC power connected to the UPS is completely cut off.
- 6) Turn off the Input/ Bypass Breaker (Q1).
- 7) Turn off the Output Breaker (Q3).
- 8) Turn off each external battery cabinet's breaker and take out every battery module (optional) from the UPS's battery module slot. For the battery module slot's location, please refer to **2.6 Internal View**. For battery module (optional) information, please refer to **5.9 Battery Module (Optional)**. For external battery cabinet information, please refer to **5.6 External Battery Cabinet Connection Warnings**.

In manual bypass mode, all power inside the UPS is completely cut off and maintenance personnel can perform maintenance safely. For manual bypass mode diagram, please see **Figure 3-18**. During manual bypass mode, the UPS's tri-color LED and LCD are both off.

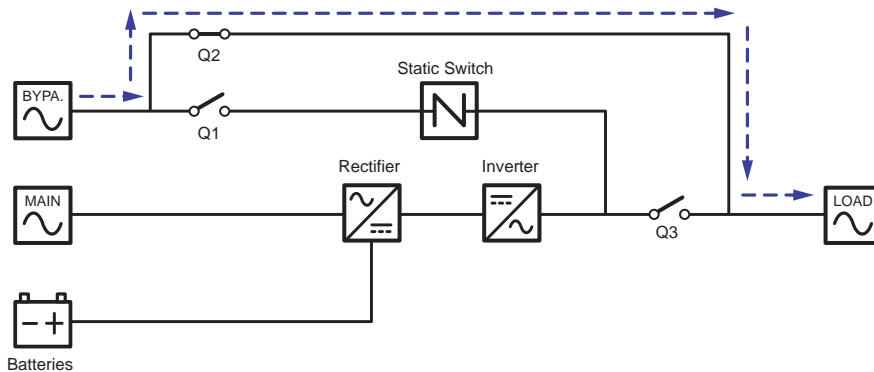

(Figure 3-18: Manual Bypass Mode Diagram_ Dual Input Single Unit)



WARNING:

1. In manual bypass mode, make sure that all of the breakers and switches (except the Manual Bypass Breaker (Q2)) are in the **OFF** position before working on the UPS's internal circuits. This avoids electric shock.
2. After the power inside the UPS is completely cut off, there is no high voltage inside the UPS except the wiring terminals and the Manual Bypass Breaker (Q2). Do not touch the wiring terminals and the Manual Bypass Breaker (Q2) during UPS maintenance process to avoid electric shock.
3. During manual bypass mode, the UPS's input power is completely cut off and the connected critical loads are not protected.

3.2.5 ECO Mode_Dual Input_Single Unit

To activate ECO mode, please refer to **6.2.5 ECO Mode Start-up Procedures**, **7.6 Main Screen** and **7.10.2 Mode Setting**.

In ECO mode, when the bypass AC source's input voltage and frequency are within the range of rating voltage $\pm 10\%$ and rating frequency $\pm 3\text{Hz}$, the UPS works in bypass mode; otherwise, the UPS runs in online mode. For ECO mode diagram, please see **Figure 3-19**. During ECO mode, the UPS's tri-color LED illuminates green and the text 'ECO' appears in the upper right corner of the screen.

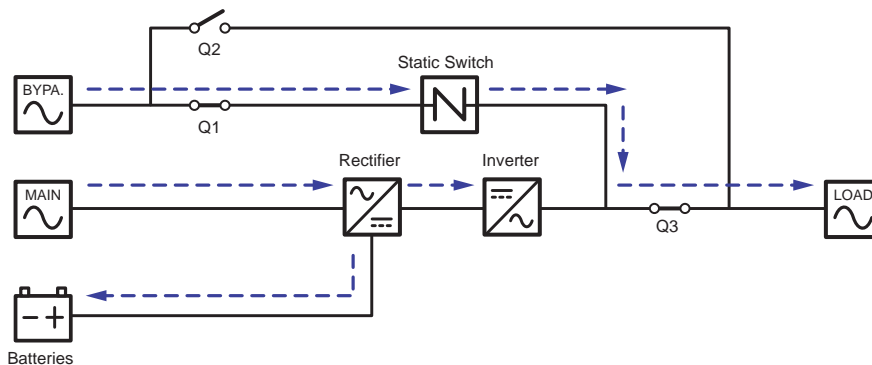

(Figure 3-19: ECO Mode Diagram_Dual Input Single Unit)

3.2.6 Frequency Conversion Mode_ Dual Input_ Single Unit

To activate frequency conversion mode, please refer to **6.2.6 Frequency Conversion Mode Start-up Procedures**, **7.6 Main Screen** and **7.10.2 Mode Setting**.

After the UPS is manually set in frequency conversion mode, the inverter will automatically select 50Hz or 60Hz as the fixed output frequency. After the output frequency is determined, the system will automatically disable the bypass function. Please note that, once the inverter shuts down, there is no bypass output. For the diagram of frequency conversion mode, please see **Figure 3-20**. During frequency conversion mode, the UPS's tri-color LED illuminates green and the text 'Frequency Conversion' appears in the upper right corner of the screen.



NOTE: During frequency conversion mode, once the inverter shuts down, there is no bypass output.

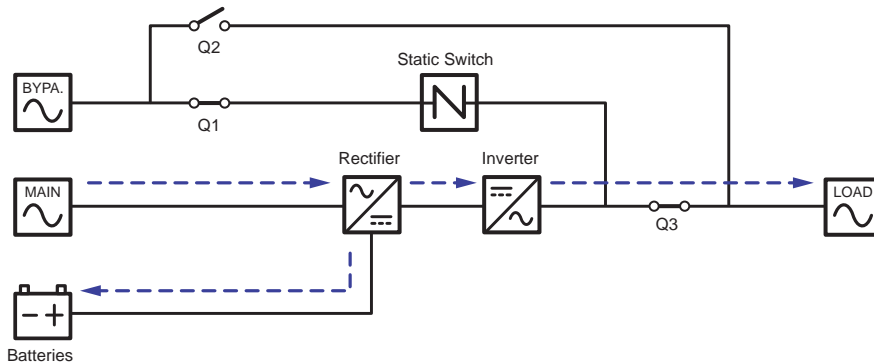

(Figure 3-20: Frequency Conversion Mode Diagram_ Dual Input Single Unit)

3.2.7 Green Mode_ Dual Input_ Single Unit

To activate green mode, please refer to **6.2.7 Green Mode Start-up Procedures**, **7.6 Main Screen** and **7.10.2 Mode Setting**.

Green mode is the same as online mode, but the difference is that the system will automatically detect the output status (i.e. total load capacity %) to decide which specific power modules should be fully powered on or idle in order to achieve higher efficiency of the UPS. For the green mode diagram, please see **Figure 3-21**. During green mode, the UPS's tri-color LED illuminates green and the text 'Green' appears in the upper right corner of the screen.

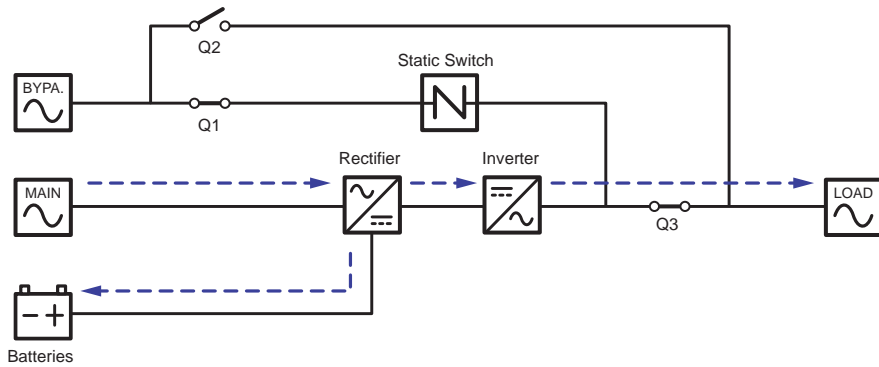

(Figure 3-21: Green Mode Diagram_ Dual Input Single Unit)

3.2.8 Online Mode_ Dual Input_ Parallel Units

In online mode (parallel), the total loads will be equally shared by the parallel UPSs. If one of the parallel units fails and its load is less than the total capacity of the remaining parallel unit, the failing UPS's output will be switched off and its load will be shared by the remaining parallel unit. If the failing UPS's load is larger than the total capacity of the remaining parallel unit, all UPSs' inverters will turn off and the total loads will be supplied by bypass power. During online mode, each UPS's tri-color LED illuminates green and each UPS's LCD shows the text 'On-Line' in the upper right corner. Please refer to **Figure 3-22** for the path of electrical power through the parallel UPSs in online mode.

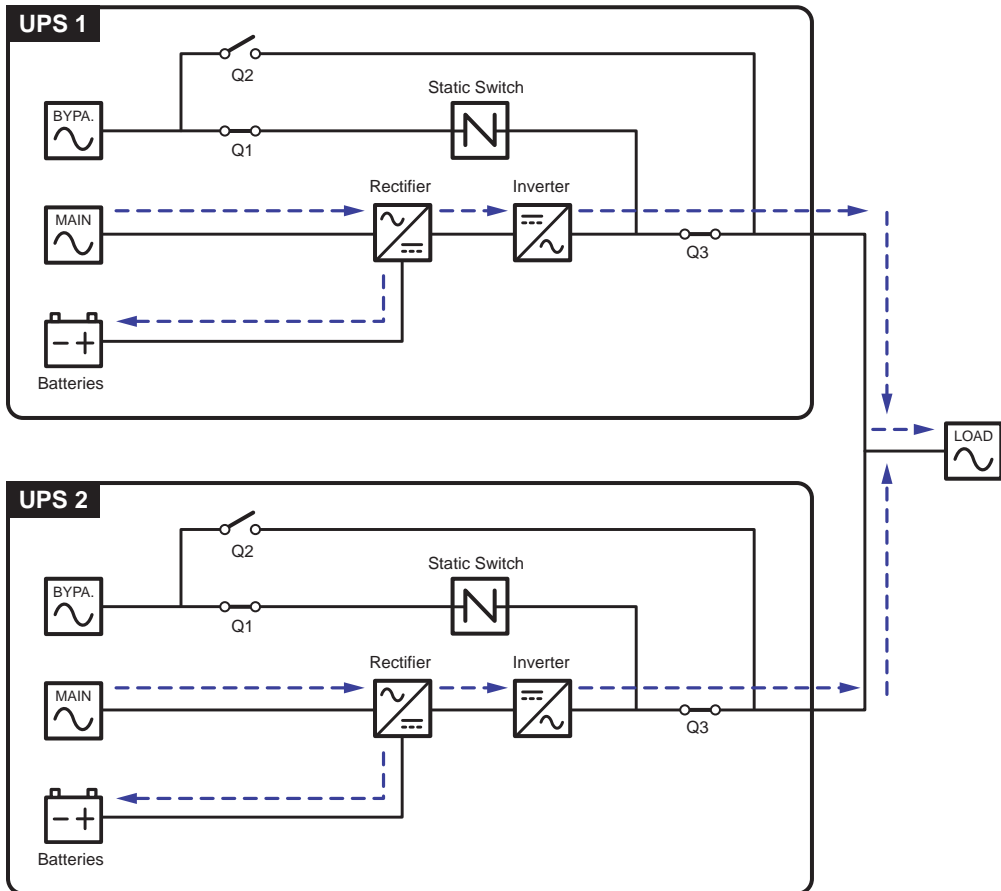

(Figure 3-22: Online Mode Diagram_ Dual Input Parallel Units)

3.2.9 Battery Mode_ Dual Input_ Parallel Units

If the main AC source cannot supply power, for example, when unstable voltage or a power outage occurs, all parallel UPSs will automatically transfer from online mode to battery mode. During the conversion process, output voltage remains the same, and during battery mode, each UPS's tri-color LED illuminates yellow and each UPS's LCD shows the text 'Battery' in the upper right corner. Please refer to **Figure 3-23** for the path of electrical power through the parallel UPSs in battery mode.

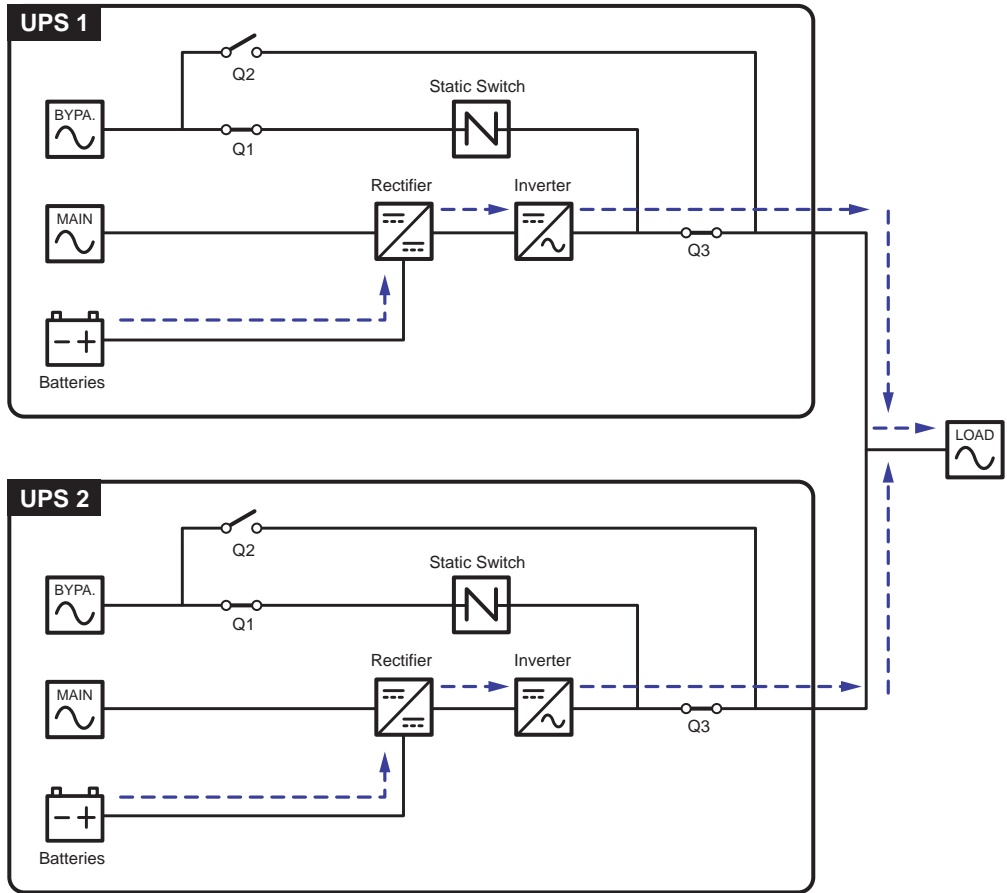

(Figure 3-23: Battery Mode Diagram_ Dual Input Parallel Units)

3.2.10 Bypass Mode_ Dual Input_ Parallel Units

In parallel mode, when all inverters encounter abnormal situations such as overload, short circuit, abnormal output voltage or low battery, they will automatically shut themselves down. Meanwhile, if all UPSs detect the bypass AC source is normal, they will automatically switch to bypass mode to protect the connected critical loads from power interruption. The critical loads will be equally shared by all parallel units. After the abnormalities mentioned above are eliminated, the UPSs will switch back to online mode from bypass mode. During bypass mode, each UPS's tri-color LED illuminates yellow and each UPS's LCD shows the text 'Bypass' in the upper right corner. Please see **Figure 3-24** for the path of electrical power through the parallel UPSs in bypass mode.

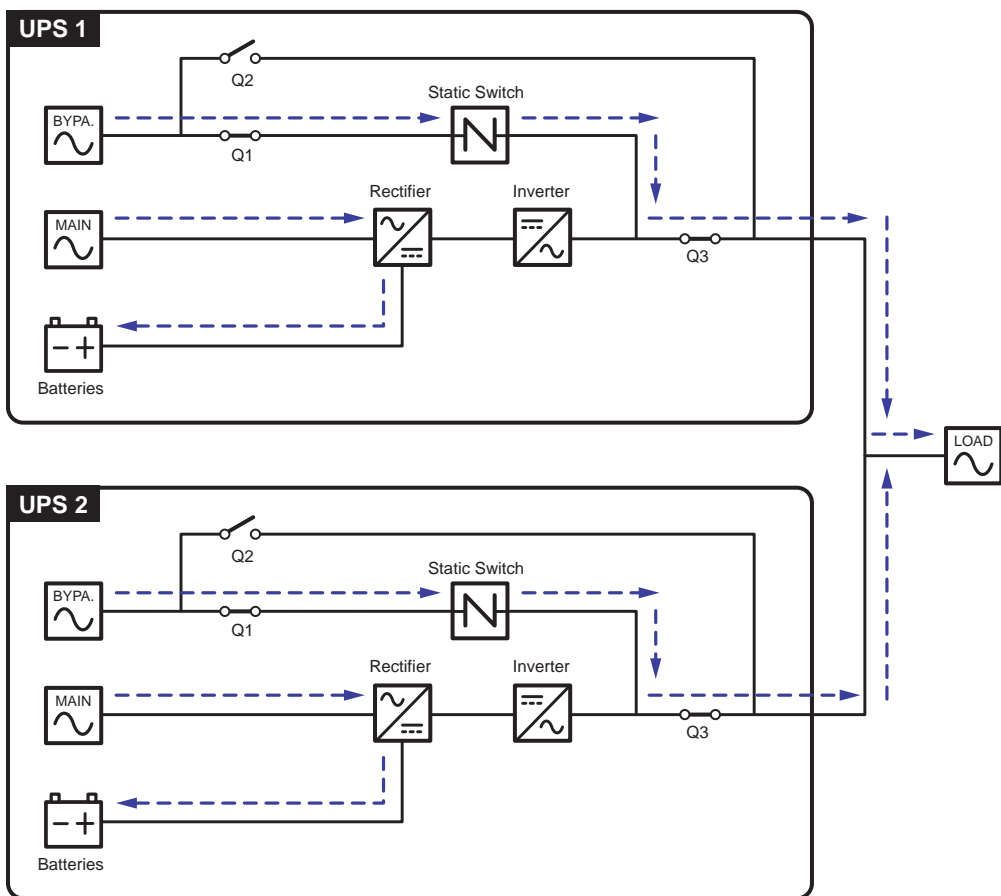

(Figure 3-24: Bypass Mode Diagram_ Dual Input Parallel Units)

3.2.11 Manual Bypass Mode_ Dual Input_ Parallel Units

In parallel mode, if one of the parallel UPSs needs maintenance, please first confirm that the bypass AC source and each parallel UPS's STS module are normal. After confirmation, please follow the procedures below to manually switch each of the parallel UPSs to manual bypass mode.

- 1 Press each LCD's ON/ OFF button () once and the 'POWER OFF?' screen will pop up to ask you if you want to power off the inverter. Please select 'YES'.
- 2 Turn on each UPS's Manual Bypass Breaker (Q2).
- 3 If the end user installs an additional Input Breaker to control the ON/ OFF status of the main AC power, please turn the user-supplied Input Breaker off.
- 4 Ensure that the main AC power connected to each parallel UPS is completely cut off.
- 5 Turn off each UPS's Input/ Bypass Breaker (Q1).
- 6 Turn off each UPS's Output Breaker (Q3).
- 7 Turn off each external battery cabinet's breaker and take out every battery module (optional) from each parallel UPS's battery module slot. For the battery module slot's location, please refer to **2.6 Internal View**. For battery module (optional) information, please refer to **5.9 Battery Module (Optional)**. For external battery cabinet information, please refer to **5.6 External Battery Cabinet Connection Warnings**.

In manual bypass mode, all power inside the parallel UPSs is completely cut off and maintenance personnel can perform maintenance safely. The connected critical loads will be supplied by the manual bypass. During manual bypass mode, all parallel UPSs' tri-color LEDs and LCDs are off. Please see **Figure 3-25** for the path of electrical power through the parallel UPSs in manual bypass mode.



WARNING:

1. In manual bypass mode, make sure that all of the breakers and switches (except each parallel UPS's Manual Bypass Breaker (Q2)) are in the **OFF** position before working on any of the parallel UPSs' internal circuits. This avoids electric shock.
2. After the power inside all parallel UPSs is completely cut off, there is no high voltage inside the parallel UPSs except each UPS's wiring terminals and Manual Bypass Breaker (Q2). Do not touch each UPS's wiring terminals and Manual Bypass Breaker (Q2) during UPS maintenance process to avoid electric shock.
3. During manual bypass mode, each parallel UPS's input power is completely cut off and the connected critical loads are not protected.



NOTE:

For parallel UPSs, if you want to turn off one of the parallel UPSs for maintenance, please make sure the connected critical loads will not exceed the remaining parallel unit's total capacity.

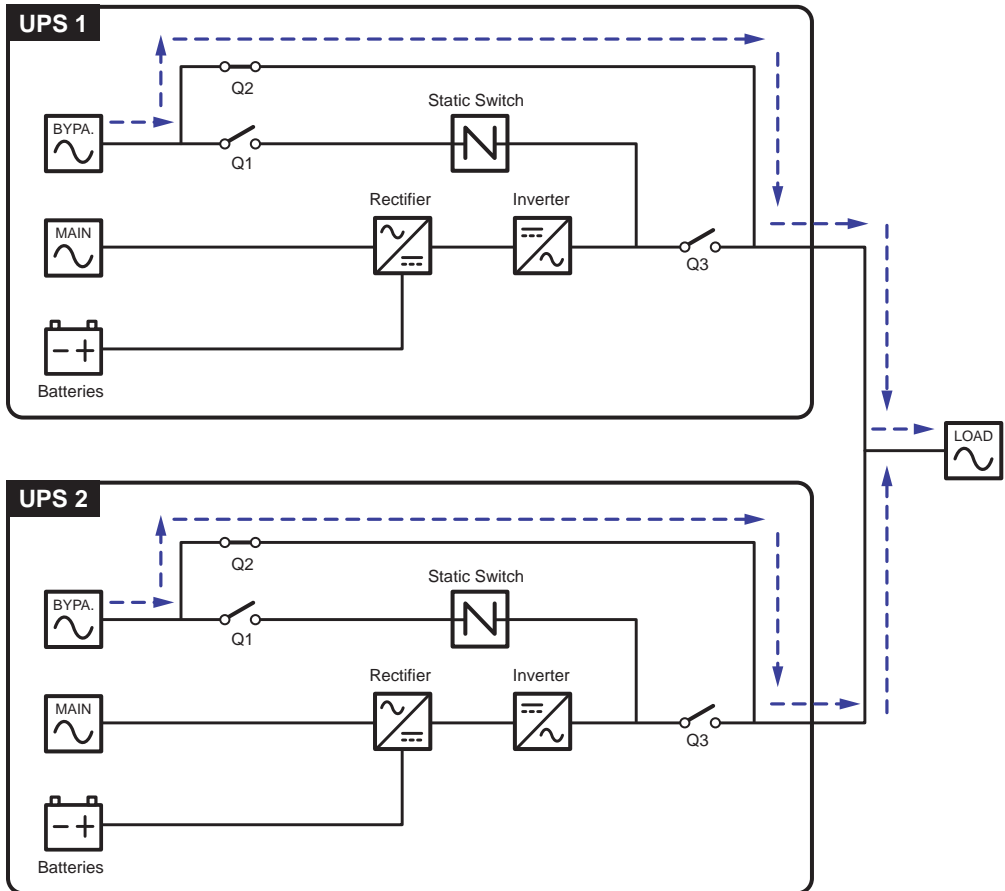

(Figure 3-25: Manual Bypass Mode Diagram_ Dual Input Parallel Units)

3.2.12 ECO Mode_ Dual Input_ Parallel Units

To activate ECO mode, please refer to **6.2.5 ECO Mode Start-up Procedures**, **7.6 Main Screen** and **7.10.2 Mode Setting**.

In ECO mode (parallel), when each UPS's bypass input voltage and frequency are within the range of rating voltage $\pm 10\%$ and rating frequency $\pm 3\text{Hz}$, each UPS works in bypass mode; otherwise, each UPS runs in online mode. During ECO mode, each UPS's tri-color LED illuminates green and each UPS's LCD shows the text 'ECO' in the upper right corner. Please see **Figure 3-26** for the path of electrical power through the parallel UPSs in ECO mode.

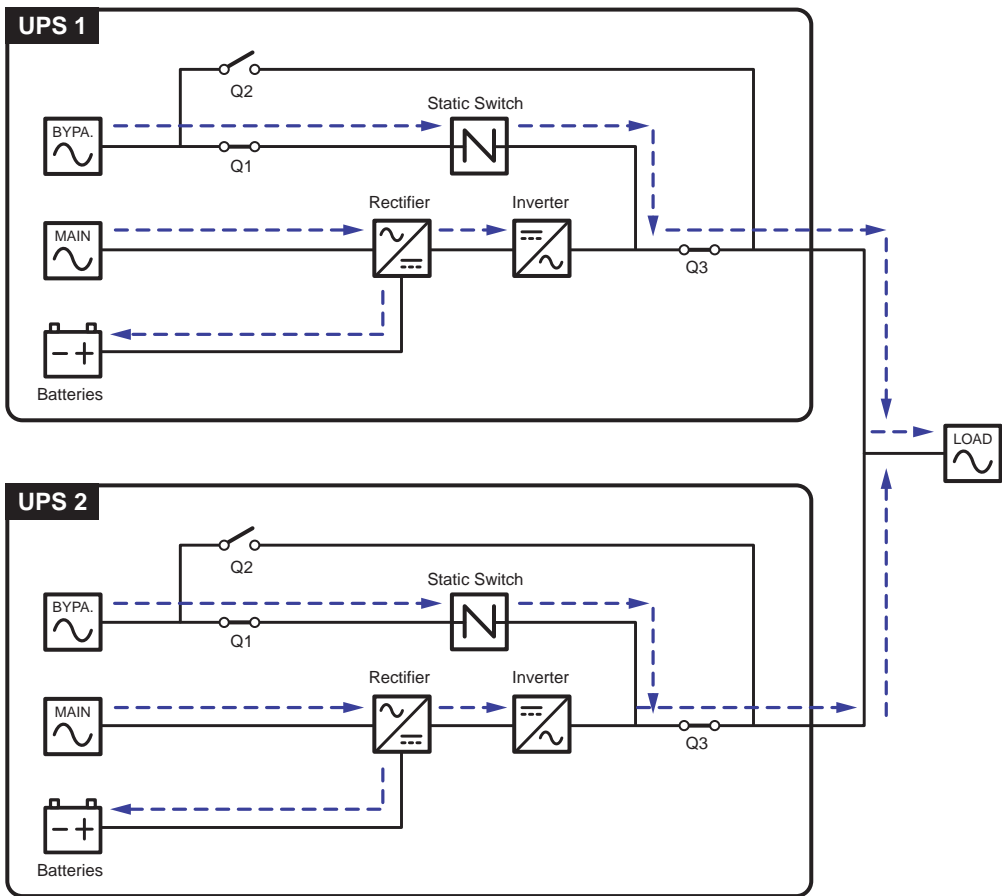

(Figure 3-26: ECO Mode Diagram_ Dual Input Parallel Units)

3.2.13 Frequency Conversion Mode_ Dual Input_ Parallel Units

To activate frequency conversion mode, please refer to **6.2.6 Frequency Conversion Mode Start-up Procedures**, **7.6 Main Screen** and **7.10.2 Mode Setting**.

For parallel application, after each of the parallel UPSs is manually set in frequency conversion mode, each inverter will automatically select 50Hz or 60Hz as the fixed output frequency. After the output frequency is determined, each system will automatically disable the bypass function. Please note that, once each inverter shuts down, there is no bypass output. During frequency conversion mode, each UPS's tri-color LED illuminates green and each UPS's LCD shows the text '**Frequency Conversion**' in the upper right corner. Please see **Figure 3-27** for the path of electrical power through the parallel UPSs in frequency conversion mode.



NOTE: During frequency conversion mode (parallel), once all of the UPSs' inverters shut down, there is no bypass output.

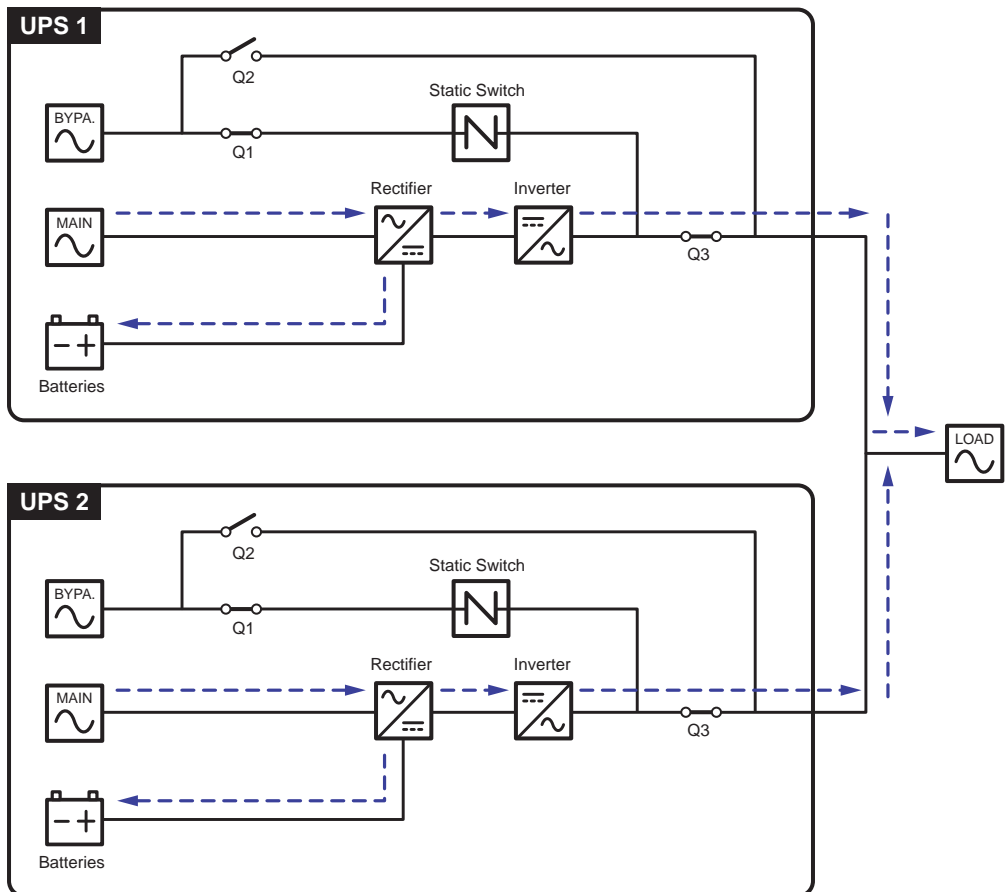

(Figure 3-27: Frequency Conversion Mode Diagram_ Dual Input Parallel Units)

3.3 Hot Standby Redundancy (Only for Dual Input & at Least Two UPSs)

To provide customers more application choices, the UPS with a dual-input configuration can have a hot standby redundancy function. If you use two UPSs and wish them to work in hot standby redundancy mode, please connect the output of UPS1 to the bypass AC source of UPS 2. Please see **Figure 3-28**. For more information about the hot standby redundancy application, please contact service personnel.

In normal condition, it is the UPS 2 inverter that supplies power to the critical loads. Both UPS 1 & UPS 2 tri-color LEDs illuminate green.

When the UPS 2 inverter becomes abnormal, the UPS 2 will automatically transfer to bypass mode and the UPS 1 inverter will supply power to the critical loads. Under such circumstances, the UPS 1 tri-color LED illuminates green and the UPS 2 tri-color LED illuminates yellow.

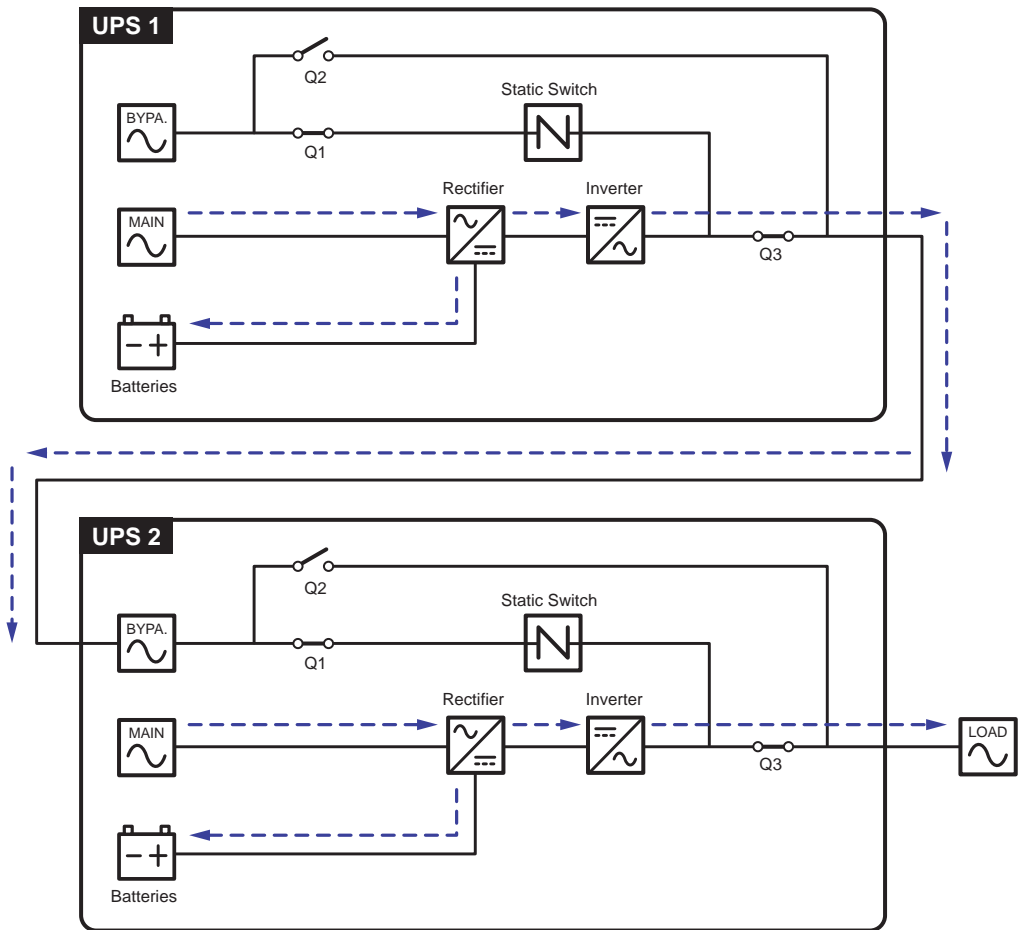

(Figure 3-28: Hot Standby Redundancy Diagram (only for Dual Input & at Least Two UPSs))

3.4 Common Battery (Only for Parallel UPSs Connecting to the Same External Battery Cabinet(s))

**NOTE:**

You can parallel UPSs. Each parallel UPS can connect with at maximum four external battery cabinets, and the parallel UPSs can share their connected external battery cabinet(s). For UPS parallel information and application, please contact Delta service personnel.

To save on your costs and installation space, the parallel UPSs can share their connected external battery cabinet(s). For common battery application, please install an isolated switch between each parallel UPS and its connected external battery cabinet(s). Please see **Figure 3-29** for two parallel UPSs sharing one external battery cabinet as an example.

If the parallel UPSs share the external battery cabinet(s), you should use the LCD to set up relevant parameters such as '**Battery Type**', '**Capacity**', '**Battery Strings**', '**Float Charge Voltage**', '**Equalized Charge Voltage**', '**Charge Current (Max)**', etc. For more information, please refer to **7.10.4 Battery & Charging Setting**.

**NOTE:**

For common battery application, please use the LCD to set each UPS's float charge voltage (default: 190V) the same, each UPS's equalized charge voltage (default: 196V) the same, and set each UPS's charge current even.

For example:

When (1) two UPSs are paralleled, (2) they share one external battery cabinet, (3) the battery type is 200AH, (4) there are a total of 4 battery strings, and (5) the charge current is 80A, please use the LCD to set each UPS's '**Battery Type**' the same, '**Capacity**' as 200AH, '**Battery Strings**' as 2, and '**Charge Current (Max)**' as 40A.

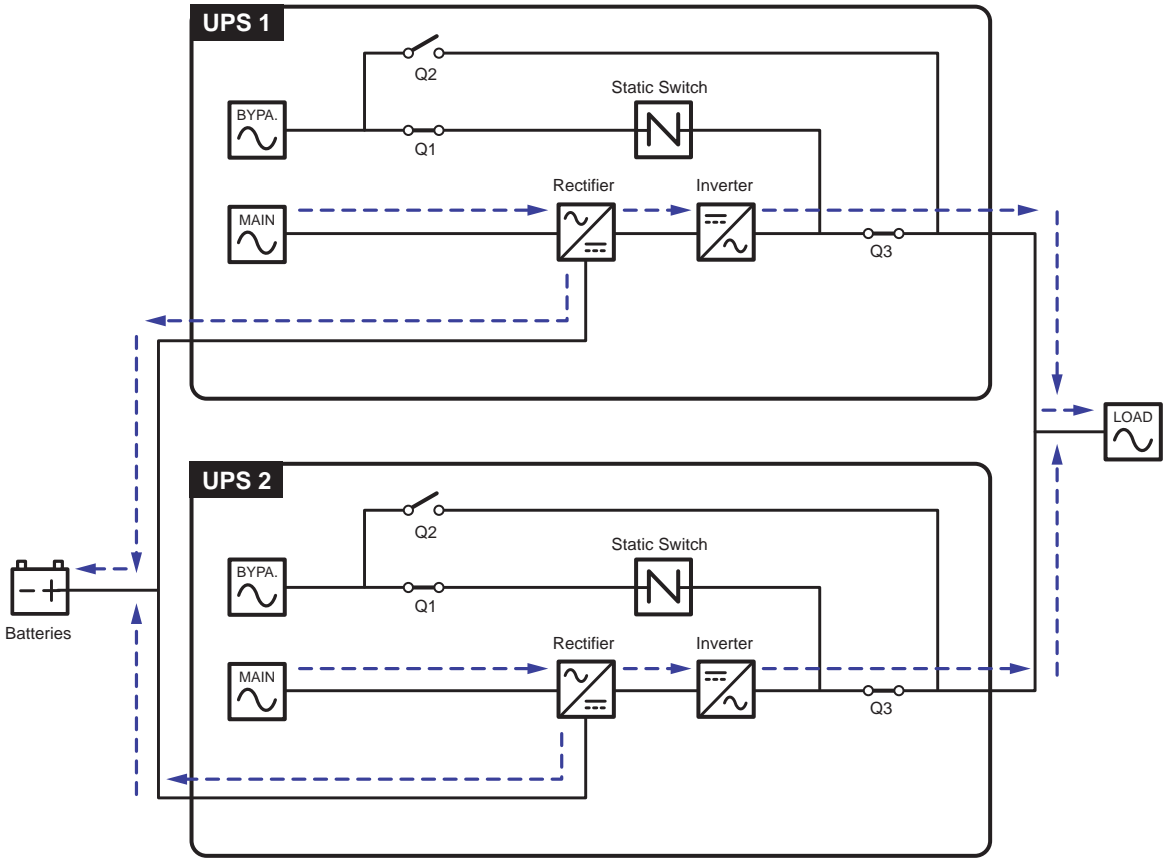

(Figure 3-29: Common Battery Diagram (only for Parallel UPSs Connecting to the Same External Battery Cabinet(s))

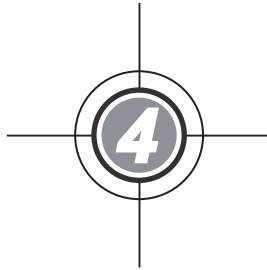

Communication Interfaces

- 4.1 Communication Interfaces on the Front of the UPS with Front Door Open
- 4.2 Communication Interfaces at the Rear of the Touch Panel

The communication interfaces are hot swappable and located at two different places. One is on the front of the UPS with front door open and the other is at the rear of the touch panel. Please see **Figure 4-1**.

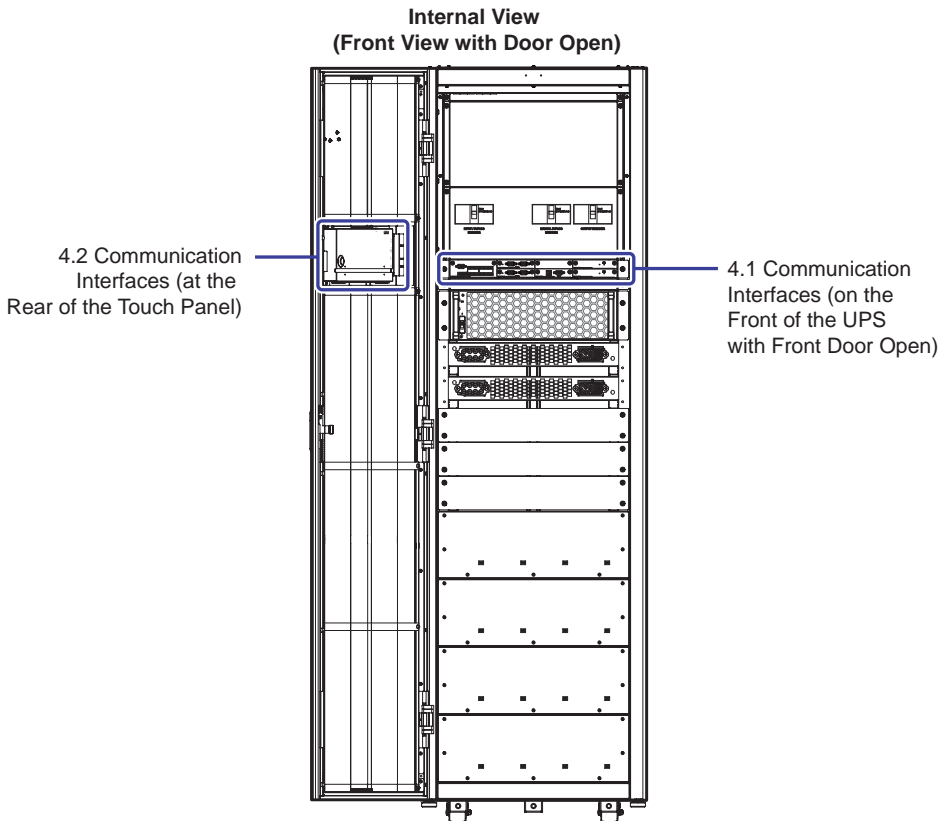

(Figure 4-1: Communication Interfaces Location)

4.1 Communication Interfaces on the Front of the UPS with Front Door Open

The following communication interfaces are located on the front of the UPS with front door open. Please see the description below.

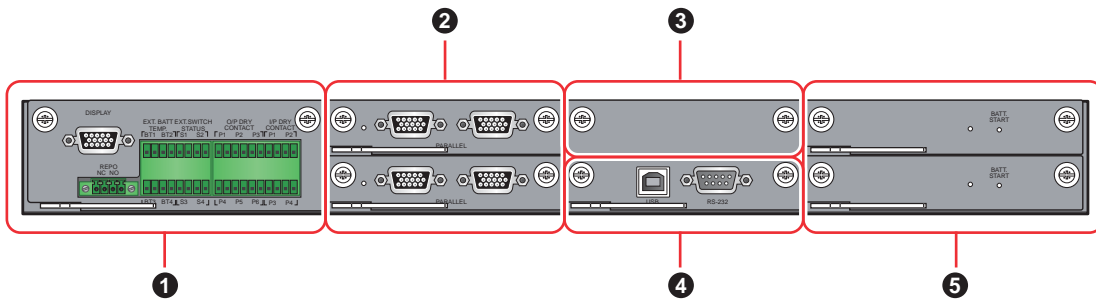

(Figure 4-2: Communication Interfaces_ on the Front of the UPS with Front Door Open)

No.	Item	Q'ty	Description
①	Dry Contact Card	1 PC	Includes a display port, REPO dry contacts, external battery temperature dry contacts, external switch/ breaker status dry contacts, output dry contacts and input dry contacts.
②	Parallel Communication Card	2 PCS	Each card includes two parallel ports and one LED indicator.
③	SMART Slot	1 PC	You can install the optional Relay I/O card for dry contact expansion.
④	System Control Card	1 PC	Includes a USB port and an RS-232 port.
⑤	Auxiliary Power Card	2 PCS	Each card includes a LED indicator and a battery start button.

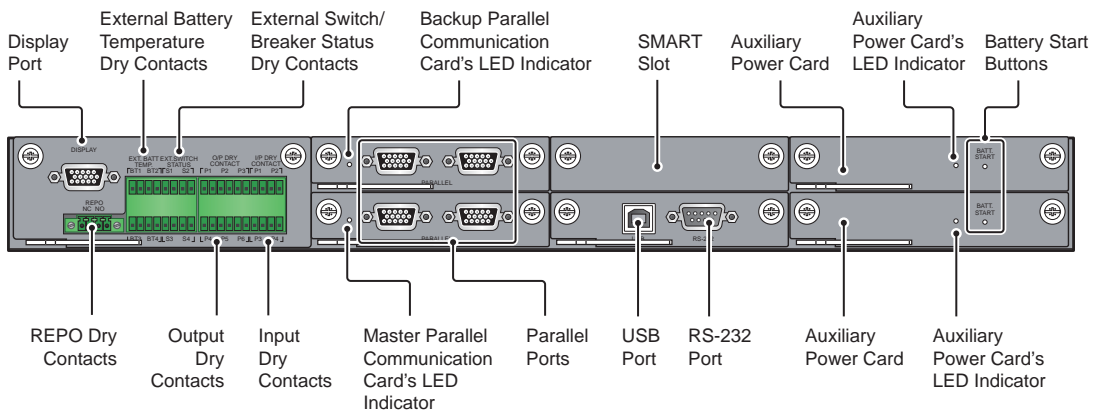

(Figure 4-3: Communication Interfaces Functions)

4.1.1 Display Port

Before shipment, the display port has been connected to the 10" touch panel with the designated cable in Delta factory.

4.1.2 REPO Dry Contacts

The REPO dry contacts provide you with quick and convenient interfaces to shut down the UPS safely when an emergency occurs. Connect the REPO dry contacts to a user-supplied switch and you can remotely shut down the UPS. The REPO dry contacts provide normally open (NO) and normally closed (NC) these two options for use.

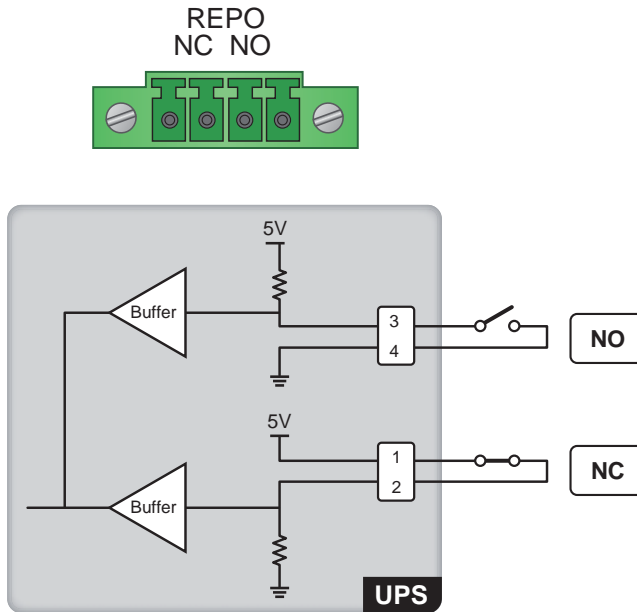

(Figure 4-4: REPO Dry Contacts Design)



NOTE:

If you want to enable the normally closed (NC) function, please take out the dry contact card (see **Figure 4-5**) and remove its Jump CNR3 (see **Figure 4-6**) before you turn on the UPS.

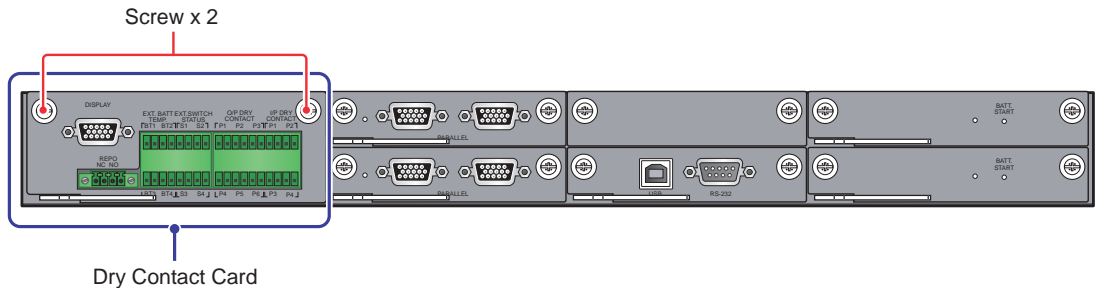

(Figure 4-5: Dry Contact Card Location)

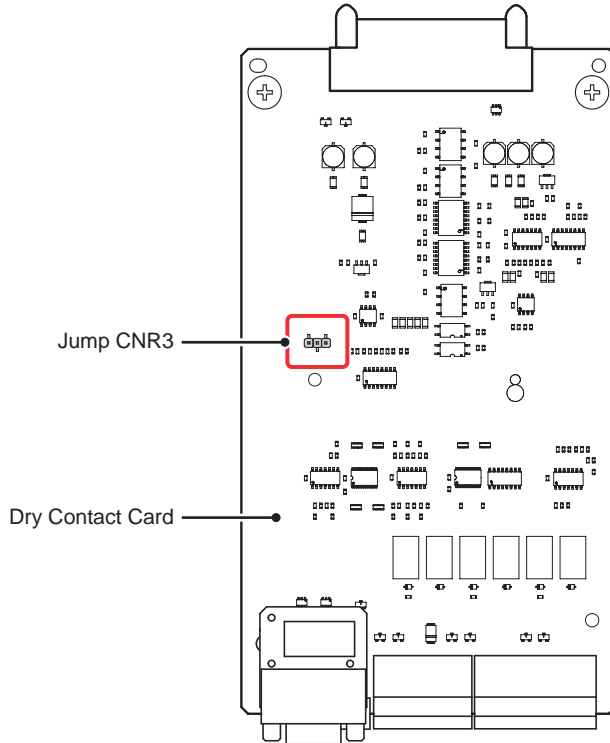

(Figure 4-6: Jump CNR3 Location)

4.1.3 External Battery Temperature Dry Contacts

You can use the external battery temperature dry contacts (BT1, BT2, BT3 and BT4) to detect at maximum four external battery cabinets' temperature. You need to purchase the battery cabinet temperature sensor cable (optional).

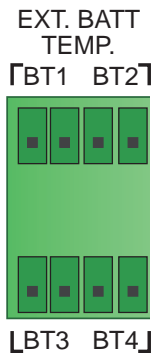

(Figure 4-7: External Battery Temperature Dry Contacts Design)

4.1.4 External Switch/ Breaker Status Dry Contacts

There are four sets of external switch/ breaker status dry contacts (S1, S2, S3 and S4), which can be used to detect the status of input, bypass, manual bypass and output switches or breakers. Please follow the table below to connect the dry contacts to normally open (NO) or normally closed (NC) devices.

Type	Connection
Dry Contact_ S1	Normally closed (NC) device
Dry Contact_ S2	Normally closed (NC) device
Dry Contact_ S3	Normally closed (NC) device
Dry Contact_ S4	Normally open (NO) device

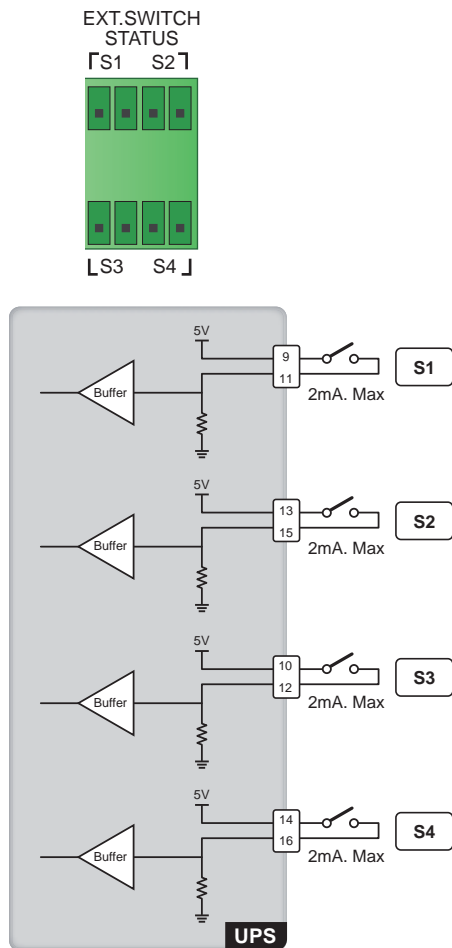

(Figure 4-8: External Switch/ Breaker Status Dry Contacts Design)

No.	Event	Description
1	External input switch or breaker detection.	Detect the external input switch or breaker's status (default: S1).
2	External bypass switch or breaker detection.	Detect the external bypass switch or breaker's status (default: S2).
3	External output switch or breaker detection.	Detect the external output switch or breaker's status (default: S3).
4	External manual bypass switch or breaker detection.	Detect the external manual bypass switch or breaker's status (default: S4).

4.1.5 Output Dry Contacts

There are six sets of programmable output dry contacts (see **Figure 4-9**). Please use the touch panel to set each dry contact as normally open (NO) or normally closed (NC). Each dry contact can be assigned with a specific event. Six out of twenty-one events can be assigned according to your applications. To learn how to set up, please contact your local dealer and refer to **7.10.6 Dry Contact Setting**. For the twenty-one events, please refer to the table below.



NOTE: Since the output dry contacts belong to the secondary circuit, the voltage of each dry contact's connected device should not exceed 60Vdc/ Vac to avoid electric shock and insufficient insulation.

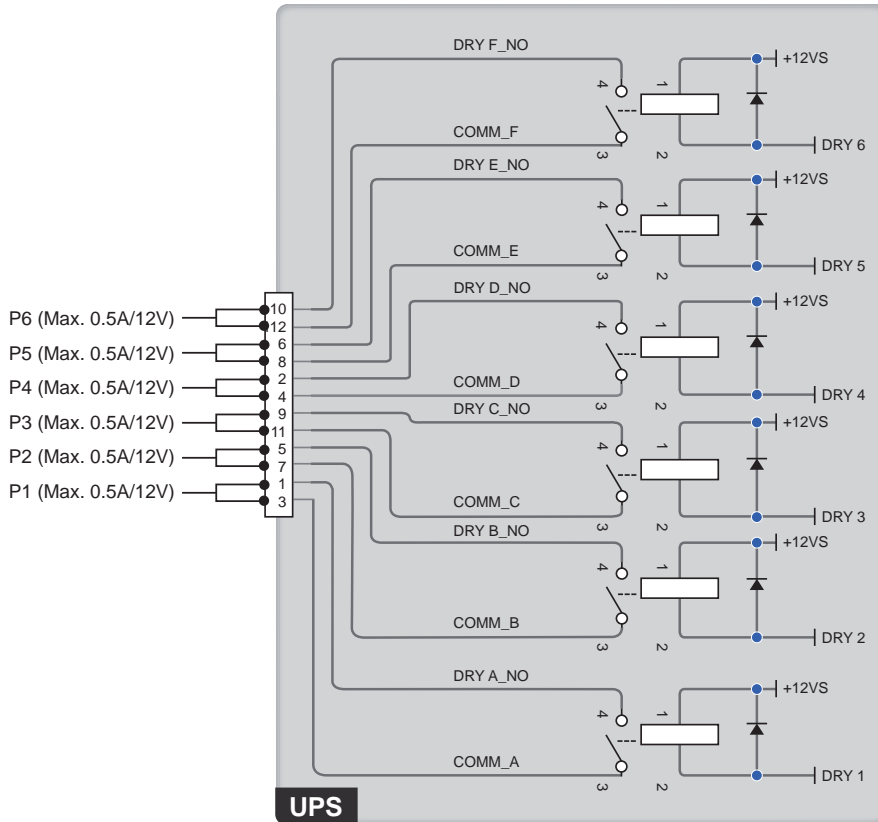
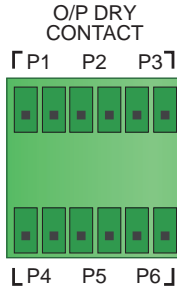

(Figure 4-9: Output Dry Contacts Design)

No.	Event	Description
1	None	No set-up.
2	Load On Inverter	The UPS works in online mode.
3	Load On Bypass	The UPS works in bypass mode.
4	Load On Battery	When the main AC source fails, the batteries supply power to the critical loads.

No.	Event	Description
5	Battery Low	When the UPS runs in battery mode, battery voltage is lower than the setup limit (default: 154Vdc).
6	Bypass Input Abnormal	The bypass voltage, frequency or phase sequence is abnormal.
7	Battery Test Fail	During the battery test, the battery voltage is out of the setup limit.
8	Internal Comm. Fail	The #n power module's internal communication is abnormal.
9	External Parallel Comm. Fail	In parallel mode, parallel communication is abnormal.
10	Output Overload	The UPS is overloaded or the UPS shuts down to let the bypass supply power to the critical loads.
11	EPO Activated	The EPO button is pressed to urgently power off the UPS.
12	Load On Manual Bypass	The Manual Bypass Breaker (Q2) is turned on and the UPS transfers to manual bypass mode.
13	Battery Over Temperature	The battery temperature is too high.
14	Output Voltage Abnormal	The output voltage is too high or too low.
15	Battery Need Replacement	The battery replacement date is due.
16	Bypass Over Temperature	The bypass static switch temperature is too high.
17	Bypass Static Switch Fault	The bypass static switch has an open/ short issue.
18	UPS Over Temperature	The UPS temperature is too high.
19	Battery Breaker Shunt Trip	When the EPO button is pressed or low battery shutdown occurs, the UPS will send a signal to the connected external shunt trip device to cut off the external battery power.
20	Backfeed Protection	When the UPS's bypass SCR has an open/ short issue, the UPS will send a signal to the connected external shunt trip device to cut off the backfeed voltage.
21	General Alarm	When any UPS alarm occurs, the UPS will send an I/ O signal.

4.1.6 Input Dry Contacts

There are four sets of programmable input dry contacts (see **Figure 4-10**). Please use the touch panel to set each dry contact as normally open (NO) or normally closed (NC). The input dry contacts allow the UPS to receive external signals from peripheral devices and let the UPS response accordingly. Each input dry contact can be assigned with a specific event. There are four events can be assigned according to your applications. To learn how to set up, please contact your local dealer and refer to **7.10.6 Dry Contact Setting**. For information about the four events, please refer to the table below.

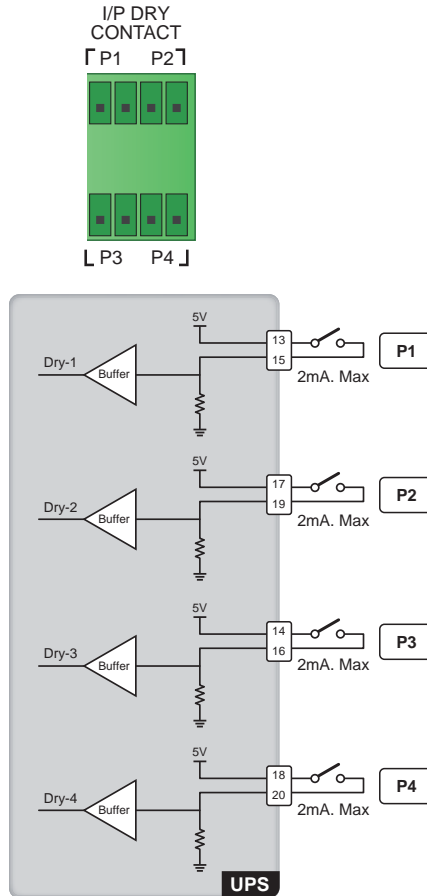

(Figure 4-10: Input Dry Contacts Design)

No.	Event	Description
1	None	No set-up.
2	Generator Status	Generator status detection.
3	Battery Ground Fail	Battery leakage detection.
4	External Battery Breaker Detection	Status detection of the external battery cabinet's breaker or switch.

4.1.7 Parallel Communication Cards

The UPS has two parallel communication cards, which are master parallel communication card and backup parallel communication card. Each card has one LED indicator. Please see **Figure 4-11** for their location.

If both cards work normally, the master parallel communication card's LED indicator will illuminate green and the backup parallel communication card's LED indicator will illuminate yellow.

If one card works normally and the other works abnormally, the normal card's LED indicator will illuminate green and the abnormal card's LED indicator will illuminate red.

During initialization process, both cards' LED indicators flash yellow.

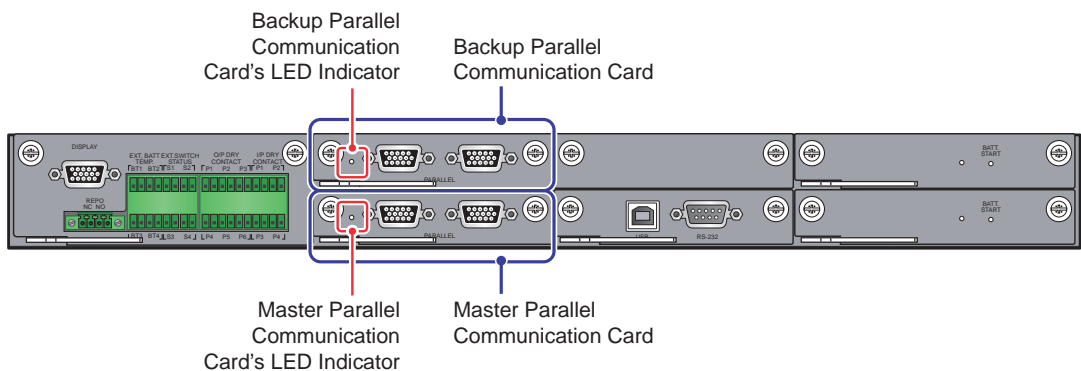

(Figure 4-11: Location of Parallel Communication Cards and Their LED Indicators)

4.1.8 Parallel Ports

The parallel ports are used to connect parallel UPSs to increase the system capacity and redundancy. With the provided parallel cable, UPS units with the same capacity, voltage and frequency can be paralleled. To enhance parallel reliability, please adopt Daisy Chain method (see **Figure 5-18** & **Figure 5-20**) to execute parallel configuration.



WARNING:

1. The provided parallel cable is placed in the accessory package. Using other types of cables to connect the parallel UPSs may cause parallel failure, malfunctions and accidents.
2. For UPS parallel information and application, please contact Delta service personnel.

4.1.9 SMART Slot

You can install the optional Relay I/O card (for dry contact expansion) into the SMART slot shown in **Figure 4-12**. For relevant installation and application information, please contact Delta customer service.

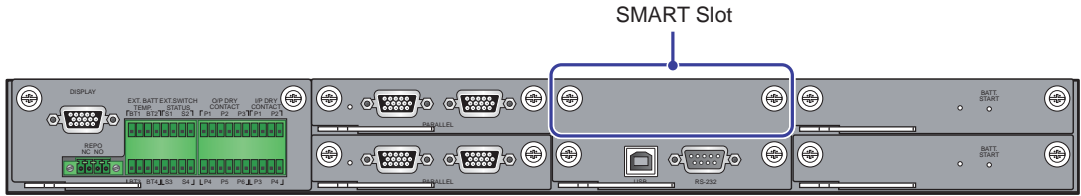

(Figure 4-12: SMART Slot Location)

4.1.10 USB Port & RS-232 Port

You can use the provided RS-232 cable or the USB cable to connect the UPS's RS-232 port or USB port with a computer, and use either the USB port or the RS-232 port to upgrade the firmware of UPS, power modules, system control card and parallel communication cards and download event logs.



NOTE: Do not use the RS-232 port and the USB port at the same time.

4.1.11 Auxiliary Power Cards

The UPS has two auxiliary power cards. Each card has one LED indicator. Please see **Figure 4-13** for their location.

If the auxiliary power card works normally, its LED indicator will illuminate green. If the auxiliary power card is off or abnormal, its LED indicator will be off.

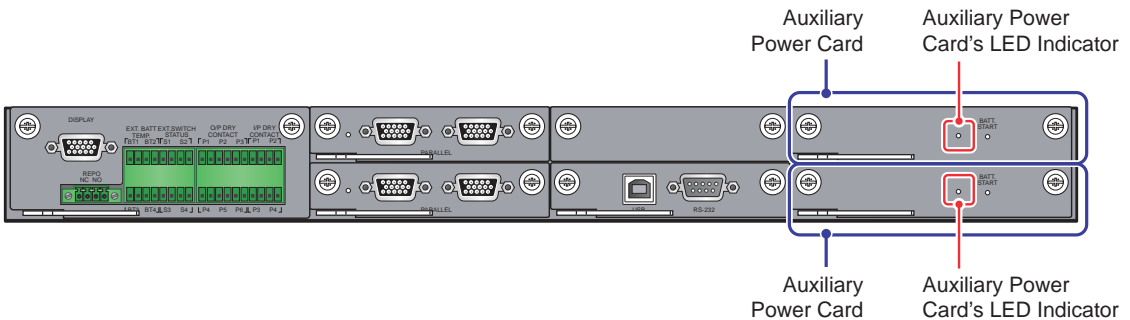

(Figure 4-13: Location of Auxiliary Power Cards and their LED Indicators)

4.1.12 Battery Start Buttons

Please refer to **6.2.2 Battery Mode Start-up Procedures** for relevant information.

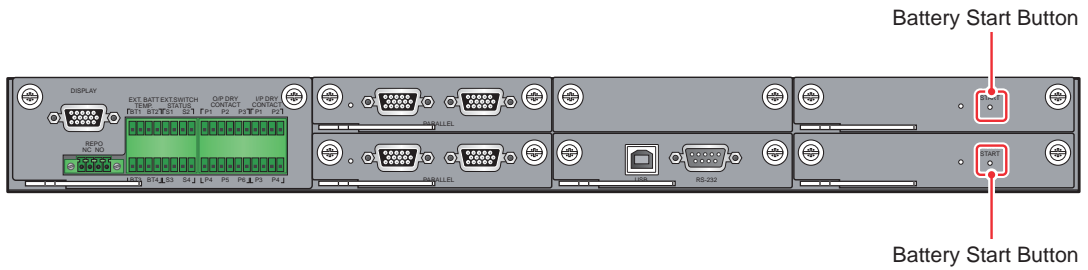



(Figure 4-14: Location of Battery Start Buttons)

4.2 Communication Interfaces at the Rear of the Touch Panel

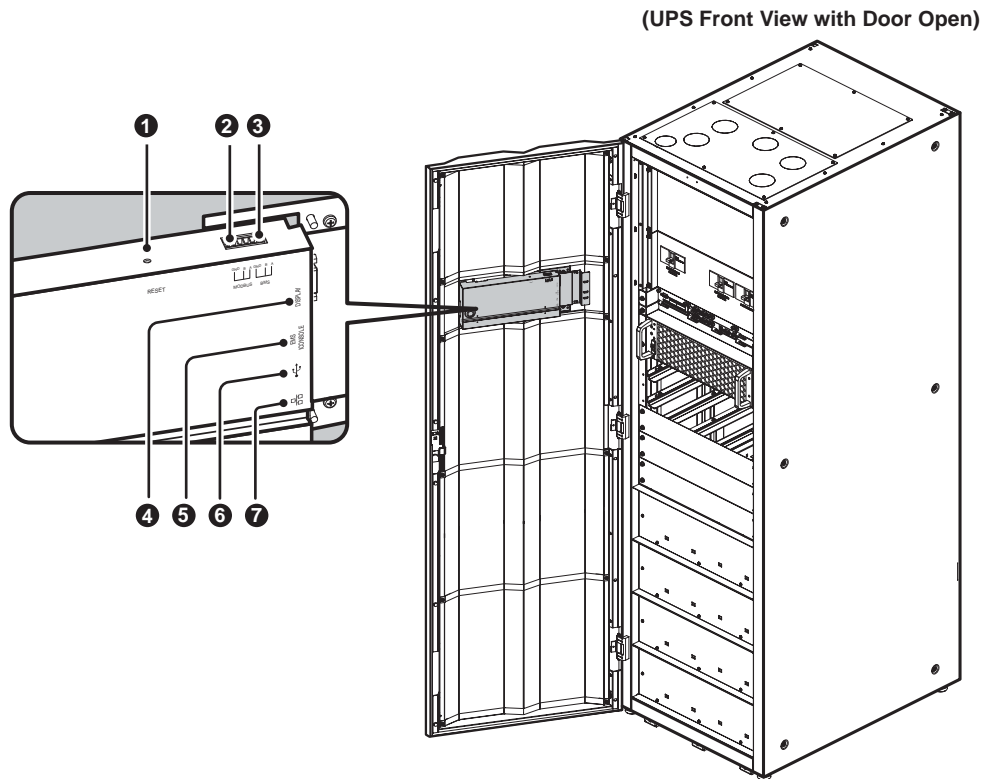
The following communication interfaces are located at the rear of the touch panel. Please see the description below.



(Figure 4-15: Communication Interfaces_ at the Rear of the Touch Panel)

No.	Item	Function
①	RESET	Press the RESET button once to restart the LCD.
②	MODBUS (RS-485 Port)	<ol style="list-style-type: none"> 1. Provides MODBUS RTU communication service. 2. Connects to user-supplied monitoring system.
③	BMS	Connects to a user-supplied battery management system or Delta battery management system (optional).
④	DISPLAY	<ol style="list-style-type: none"> 1. Connects to the display port shown in Figure 4-3. 2. Before shipment, the display port has been connected to the 10" touch panel with the designated cable in Delta factory.
⑤	EMS/ CONSOLE	Connects to a user-supplied environmental monitoring system or Delta EnviroProbe 1000/ 1100/ 1200 (optional).
⑥	 (USB Ports)	There are two USB ports. Connect a user-supplied USB flash drive to any of the USB ports to (1) upgrade the UPS and LCD's firmware and (2) download event logs.
⑦	 (Network Port)	<ol style="list-style-type: none"> 1. Provides network communication service (including SNMP, MODBUS TCP, HTTP, HTTPS, etc.). 2. Connects to user-supplied monitoring system.

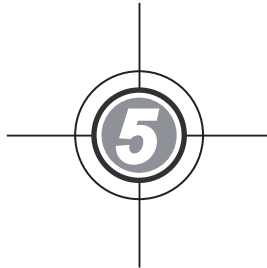

Installation and Wiring

- 5.1 Before Installation and Wiring
- 5.2 Installation Environment
- 5.3 UPS Transportation
- 5.4 Fixing the UPS
- 5.5 Wiring
- 5.6 External Battery Cabinet Connection Warning
- 5.7 STS Module
- 5.8 Power Module (Optional)
- 5.9 Battery Module (Optional)

5.1 Before Installation and Wiring

1. Please read this user manual thoroughly before installation, wiring and usage. Only authorized Delta engineers or service personnel can perform installation, wiring, panel & cover removal, maintenance and operation. If you want to execute any action mentioned above by yourself, the action must be under the supervision of authorized Delta engineers or service personnel. If you use a forklift or other equipment to move the UPS, please make sure its load bearing is sufficient. Please refer to **Table 5-1**.
2. You can install at maximum sixteen battery modules (optional) inside the UPS cabinet. For relevant information, please refer to **5.9 Battery Module (Optional)**. To extend backup time, the UPS can be connected with at maximum four external battery cabinets (user-supplied, handled and configured by Delta service personnel). Please refer to **5.6 External Battery Cabinet Connection Warnings** for relevant information.
3. In this user manual, the meaning of Q1, Q2 and Q3 represents the following.

Code	Meaning
Q1	Input/ Bypass Breaker
Q2	Manual Bypass Breaker
Q3	Output Breaker

5.2 Installation Environment

- Install the UPS indoors. Do not place it outdoors.
- Make sure that transportation routes (e.g. corridors, door gates, elevators, etc.) and installation area can accommodate and bear the weight of the UPS, external battery cabinet and handling equipment. Please refer to **Table 5-1** for floor weight loading information.

Table 5-1: UPS Floor Weight Loading Table

DPH Series UPS_ 15~ 60kVA				
UPS Capacity	15kVA/ 15kW	30kVA/ 30kW	45kVA/ 45kW	60kVA/ 60kW
Power Module Q'ty	1+1	2+1	3+1	4+1
Maximum Battery Module Q'ty	16	16	16	16
Weight	1488 lb 675 kg	1537 lb 697 kg	1583 lb 718kg	1629 lb 739kg
Weight Loading	271.1 lb/ft ² 1323.6 kg/m ²	279.6 lb/ft ² 1365.1 kg/m ²	288.1 lb/ft ² 1406.7 kg/m ²	296.6 lb/ft ² 1448.3 kg/m ²

- The UPS adopts top wiring. Please leave adequate space on the top of the UPS to allow cable entry.
- Ensure that the installation area is big enough for maintenance and ventilation. Since the UPS adopts the design of air inlet at the front and air outlet at the rear, we suggest that you:

1. Keep a distance of 39.4" (100 cm) from the front of the UPS for maintenance and ventilation.
 2. Keep a distance of 7.9" (20 cm) from the back of the UPS for ventilation.
 3. Keep a distance of 17.7" (45 cm) from the top of the UPS for wiring, maintenance and ventilation.
- Keep the installation area clean. Please note that wiring routes must be hermetic to prevent possible damage from rodents.
 - Keep the installation area's temperature around 77°F (25°C) and humidity below 95%. The highest operating altitude is 3280 ft (1000 m) above sea level.
 - For safety concerns, we suggest that you:
 1. Equip surroundings of the installation area with CO₂ or dry powder fire extinguishers.
 2. Install the UPS in an environment where fireproof materials are used to construct the walls, floors and ceilings.
 3. Install the UPS on a floor that is made of noncombustible materials.
 - Do not allow unauthorized personnel to enter the installation area and assign specified personnel to keep the UPS key.



WARNING: Do not use air conditioners or similar equipment to blow into the rear of the UPS and hinder ventilation.

5.3 UPS Transportation

- At the bottom of the UPS, there are six casters to help you to move the UPS to a designated area. Before you move the UPS, please turn the four leveling feet counterclockwise to raise them off the ground. This protects the leveling feet from damage when moving the UPS. Please use sufficient manpower (at least six people) and equipment (e.g. forklift) to carefully move the UPS from its pallet to ground. Please pay attention to the movement of the casters to avoid accidents.

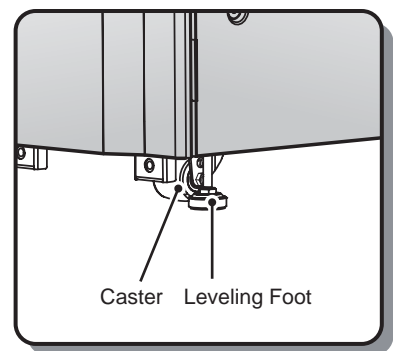

(Figure 5-1: UPS Leveling Foot and Caster)



NOTE:

1. The UPS is fixed on the pallet with two balance supports. When taking apart the two balance supports from the UPS, please pay attention to the movement of the casters to avoid accidents.
2. Please refer to the **Unpacking Guide** attached to the UPS external wooden box for location of the balance supports.

- The casters are designed to move on level ground. Do not move the UPS on an uneven surface. This might cause damage to the casters or tip the UPS, which could damage the unit.
- After the UPS has been removed from the pallet to ground, we suggest that at least three people move the UPS to the installation area. One person use their hands to hold a lateral side of the UPS, one person hold the other lateral side of the UPS with their hands, and one person use their hands to push the UPS either from the front side or from the backside to move the unit to the installation area and avoid tipping the UPS.
- If you need to move the UPS over a long distance, please use appropriate equipment like a forklift. Do not use the UPS casters to move the unit over a long distance.

5.4 Fixing the UPS

Please follow the steps below:

- 1 Before fixing the UPS in a designated installation area, please double check whether the area's floor weight loading is sufficient to bear the UPS, external battery cabinet and handling equipment (i.e. forklift) to avoid accidents. For UPS floor weight loading information, please refer to **Table 5-1**.
- 2 After the UPS is moved to the designated installation area, use a #17 wrench to stabilize the UPS four leveling feet on the floor. Please note that the UPS must stand on the floor stably and levelly without any tipping.
- 3 Use a 17mm socket wrench and three M10 screws **1** (originally used to fix the front balance support on the pallet) to install the front balance support (removed during the unpacking process) at the front of the UPS. Use the three expansion screws & nuts **2** (provided by service personnel) to fix the front balance support on the ground to avoid UPS movement. Please see **Figure 5-2**.

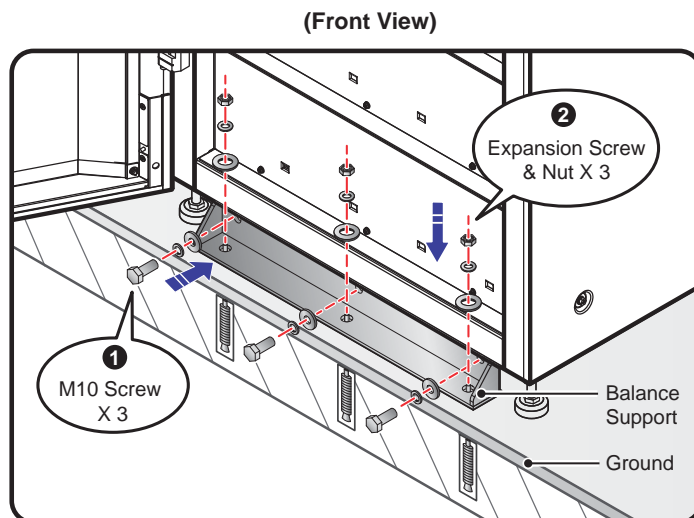

(Figure 5-2: Install the Balance Support at the Front of the UPS)

- 4 Use a 17mm socket wrench and three M10 screws ① (originally used to fix the rear balance support on the pallet) to install the rear balance support (removed during the unpacking process) at the rear of the UPS. Use the three expansion screws & nuts ② (provided by service personnel) to fix the rear balance support on the ground to avoid UPS movement. Please see **Figure 5-3**.

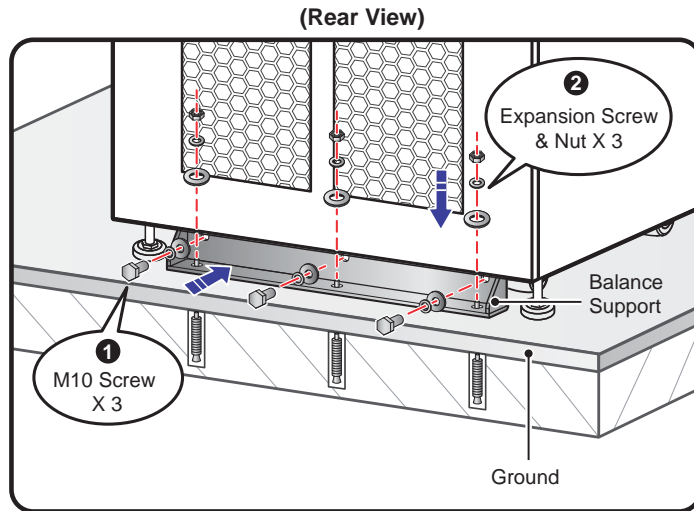

(Figure 5-3: Install the Balance Support at the Rear of the UPS)



WARNING:

If you don't use the balance supports to fix the UPS on the ground, the unit might topple over. For safety concerns, please use the balance supports to fix the UPS to the floor.

- 5 Follow **5.5 Wiring** to perform wiring procedures.
- 6 If on-site requirements need to install the external battery cabinet (at maximum four), follow **5.6 External Battery Cabinet Connection Warnings** to install the external battery cabinet.
- 7 Follow **5.8 Power Module (Optional)** to install the power modules.
- 8 If on-site requirements need to install the battery modules (optional; at minimum four; at maximum sixteen), follow **5.9 Battery Module (Optional)** to install the battery modules.
- 9 After finishing the procedures above, close the UPS front door.

5.5 Wiring

5.5.1 Pre-wiring Warnings



NOTE:

1. Before wiring, please ensure that you have followed **5.4 Fixing the UPS** to fix the UPS in the designated installation area firmly.
 2. Before wiring, please read **5.5 Wiring thoroughly**.
 3. Only authorized Delta engineers or service personnel can perform installation, wiring, panel & cover removal, maintenance and operation. If you want to execute any action mentioned above by yourself, the action must be under the supervision of authorized Delta engineers or service personnel.
 4. For battery installation, please refer to **5.6 External Battery Cabinet Connection Warnings** and **5.9 Battery Module (optional)**.
- Before wiring or making any electrical connection, make sure that the power supplied to the input and output of the UPS is completely cut off.
 - The UPS adopts top wiring. Please leave adequate space on the top of the UPS to allow cable entry.
 - Check that the size, diameter, phase, polarity are correct for each cable that needs connecting to the UPS. Please refer to **Table 5-2**.



NOTE:

Table 5-2 is based on (1) default input/ output voltage: 120V, (2) default battery Q'ty: 28PCS and (3) default charge current per power module: 1.5A. For other conditions different from **Table 5-2**, please contact service personnel for relevant values.

Table 5-2: Specifications of Input/ Output/ Battery Cables and Breakers

DPH 15 ~ 60kVA					
Capacity		15kVA/ 15kW	30kVA/ 30kW	45kVA/ 45kW	60kVA/ 60kW
Power Module Q'ty		1+1	2+1	3+1	4+1
Input	Rated current at input voltage 120V (in the status of battery charging)	46A	92A	138A	184A
	Recommended cable size (L1/ L2/ L3/ N/ PE)	6 AWG (13 mm ²) × 1 PC	1 AWG (42 mm ²) × 1 PC	3/ 0 AWG (85 mm ²) × 1 PC	4/ 0 AWG (107 mm ²) × 1 PC
	Maximum cable size (L1/ L2/ L3/ N/ PE)	250 kcmil (125 mm ²) × 1 PC			

DPH 15 ~ 60kVA					
Input	Cable lug width	1.1" (28 mm)			
	Screw size	M8			
Output	Rated current at output voltage 120V	42A	83A	125A	167A
	Recommended cable size (L1/ L2/ L3/ N/ PE)	6 AWG (13 mm ²) × 1 PC	1 AWG (42 mm ²) × 1 PC	3/ 0 AWG (85 mm ²) × 1 PC	4/ 0 AWG (107 mm ²) × 1 PC
	Maximum cable size (L1/ L2/ L3/ N/ PE)	250 kcmil (125 mm ²) × 1 PC			
	Cable lug width	1.1" (28 mm)			
	Screw size	M8			
Battery	Nominal discharge current (condition: per cell 2V)	48A	95A	143A	190A
	Recommended cable size (+/- Battery N)	6 AWG (13 mm ²) × 1 PC	1 AWG (42 mm ²) × 1 PC	3/ 0 AWG (85 mm ²) × 1 PC	4/ 0 AWG (107 mm ²) × 1 PC
	Maximum cable size (+/- Battery N)	250 kcmil (125 mm ²) × 1 PC			
	Cable lug width	1.1" (28 mm)			
	Screw size	M8			
Tightening Torque		M8= 130 ± 4.4 lb-in (150 ± 5 Kgf-cm)			
Input/ Bypass Breaker (Q1)		225A	225A	225A	225A
Manual Bypass Breaker (Q2)		225A	225A	225A	225A
Output Breaker (Q3)		225A	225A	225A	225A

**NOTE:**

1. In accordance with National Electrical Codes (NEC), please install a suitable conduit and bushing for cable protection.
2. Please refer to national and local electrical codes for acceptable non-fuse breakers and cable size.
3. The cables mentioned in **Table 5-2** with PVC material and with temperature resistance up to 221 °F (105°C) are suggested.
4. The tightening torque for M8 screw should be 130 ± 4.4 lb-in (150 ± 5 Kgf-cm).

- To avoid UPS failure, the input of the UPS must be Y connection.
- If there is a floating voltage between the input power's neutral (N) and the ground (⊕), and you require that the VNG of the UPS should be zero, we suggest that you install an isolation transformer in front of the input side of the UPS, and connect the isolation transformer's secondary neutral (N) and the ground (⊕) to the nearest place of the transformer.
- The main AC source must be a three-phase four-wire system and meets the specifications specified on the UPS rating label. For main AC source connection, make sure it is in positive phase sequence. Please refer to **5.5.3 Single Unit Wiring** and **5.5.4 Parallel Units Wiring** for wiring information.
- For external battery cabinet connection, please check the battery polarity. Do not connect the batteries in reverse. Please refer to **5.6 External Battery Cabinet Connection Warnings**.
- Connect the external battery cabinet's grounding terminal (⊕) to the UPS's grounding terminal (⊕). Please refer to **Figure 5-15** and **Figure 5-19** for grounding information.
- The UPS's grounding terminal (⊕) must be grounded and please use ring-type terminals when wiring. For the location of the UPS's grounding terminal (⊕), please refer to **Figure 5-12**.



WARNING:

1. Wrong wiring will cause damage to the UPS and electric shock.
2. If the UPS is not grounded, the power boards and components might be damaged after the UPS is powered on.

5.5.2 Single Input/ Dual Input Modification



WARNING: Only authorized Delta engineers or service personnel can modify single input/ dual input setup.

The UPS default setting is single input. If you want to modify it into dual input, please follow the procedures below.

- 1 Follow **Figure 5-4** to remove the left side panel (there are six screws) and find the AC/ Bypass Input Cooper Bars and AC Input Cooper Bars shown in **Figure 5-5** and **Figure 5-6**.

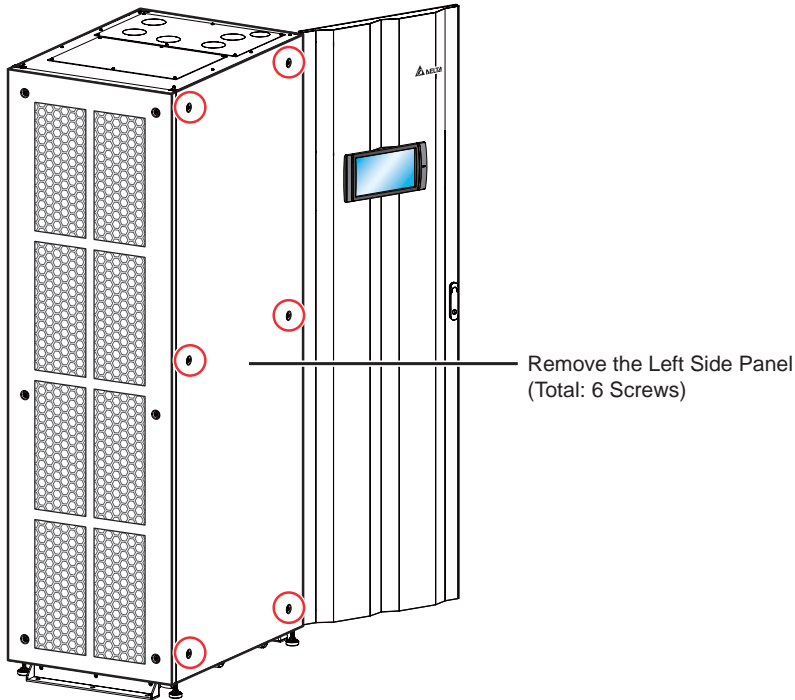

(Figure 5-4: Location of Left Side Panel and Six Screws)

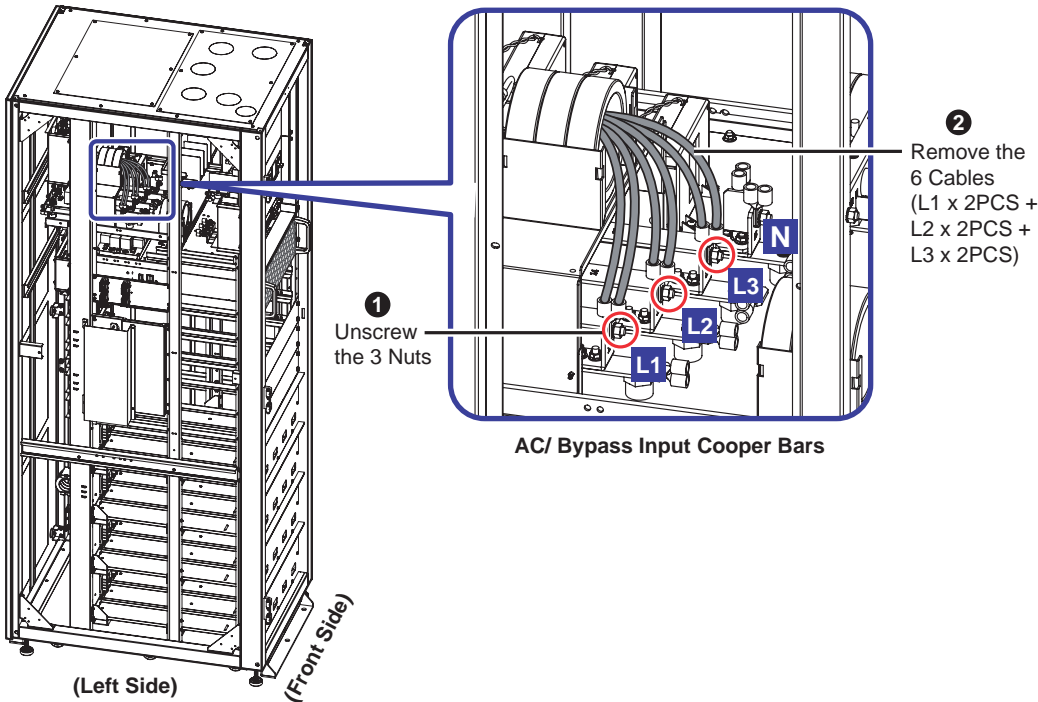

(Figure 5-5: Location of AC/ Bypass Input Cooper Bars)

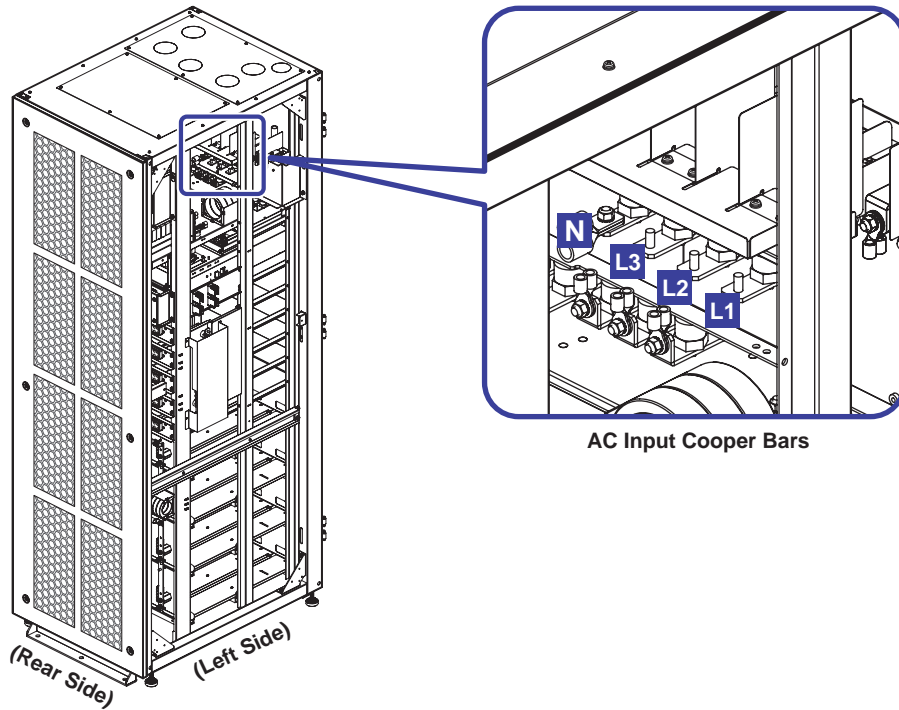

(Figure 5-6: Location of AC Input Cooper Bars)

- ② ① Unscrew the three nuts of the AC/ Bypass Input Cooper Bars, ② remove the six cables (L1 x 2PCS, L2 x 2PCS & L3 x 2PCS) originally connected to the AC/ Bypass Input Cooper Bars, and ③ connect the six cables to the AC Input Cooper Bars.

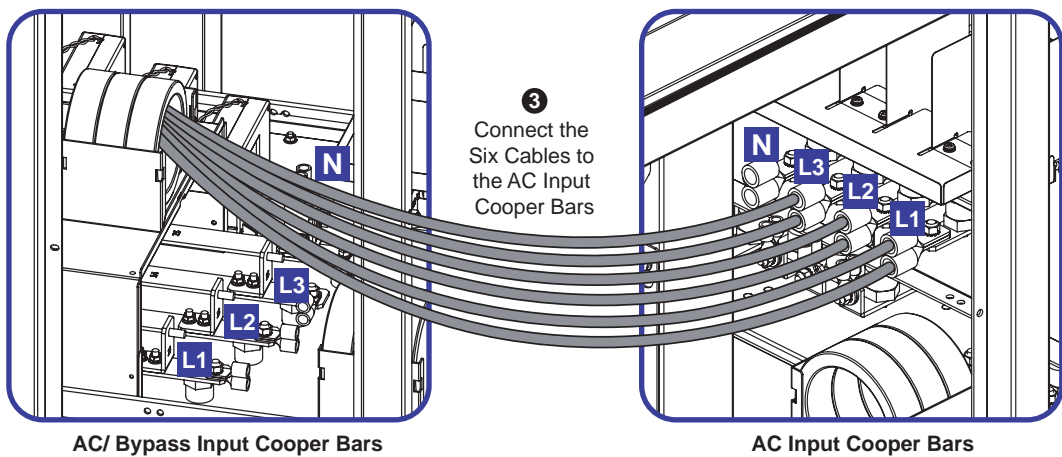

(Figure 5-7: Connect the Six Cables to the AC Input Cooper Bars)

**NOTE:**

1. Please keep the three nuts well for future use.
2. If you want to modify the UPS from dual input into single input, please reverse the actions mentioned above.

5.5.3 Single Unit Wiring

**NOTE:**

1. Only authorized Delta engineers or service personnel can perform installation, wiring, panel & cover removal, maintenance and operation. If you want to execute any action mentioned above by yourself, the action must be under the supervision of authorized Delta engineers or service personnel.
2. The UPS rating voltage is 120/ 208Vac or 127/ 220Vac.
3. The external battery cabinet's rating voltage is ± 168 Vdc.
4. Before wiring, please read **5.5 Wiring** thoroughly.

- **Single Input (Single Unit)**

When there is only one AC power source, single unit wiring procedures are as follows.

- 1 The UPS adopts top wiring. Please leave adequate space on the top of the UPS to allow cable entry.
- 2 Remove the six round covers on the top of the UPS for cable entry. For the round covers' location, please refer to **Figure 5-8**.

Internal View (Front View with Door Open)

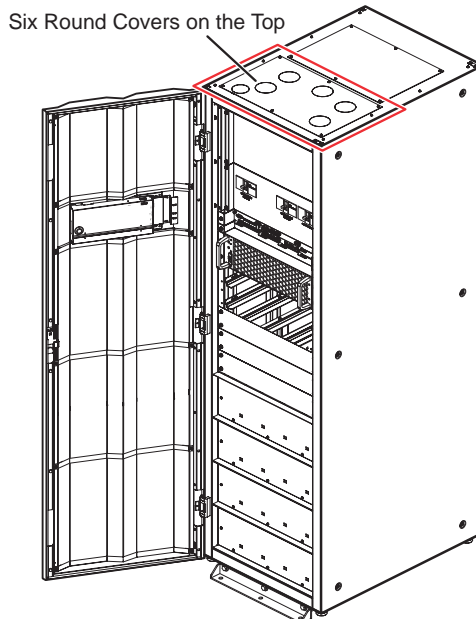

(Figure 5-8: Location of Six Round Top Covers)

- 3 Remove the wiring terminal cover (there are four screws (see **Figure 5-9**) and find the wiring terminals shown in **Figure 5-10 ~ Figure 5-12**.

Internal View
(Front View with Door Open)

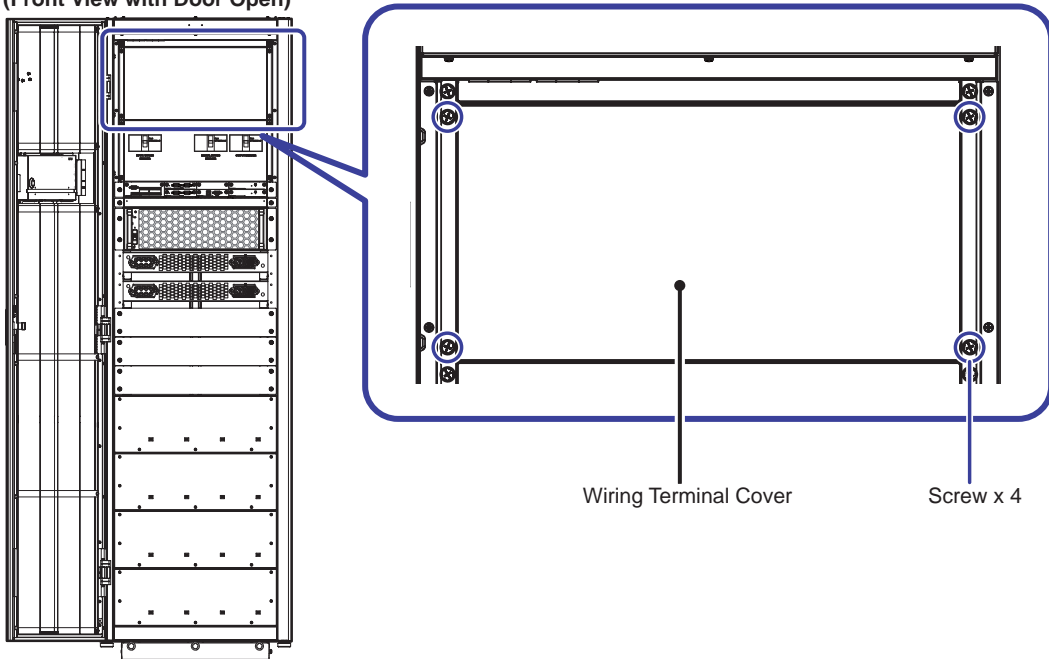

(Figure 5-9: Wiring Terminal Cover & Screws Location)

(Internal View with Door Open and
Wiring Terminal Cover Removal)

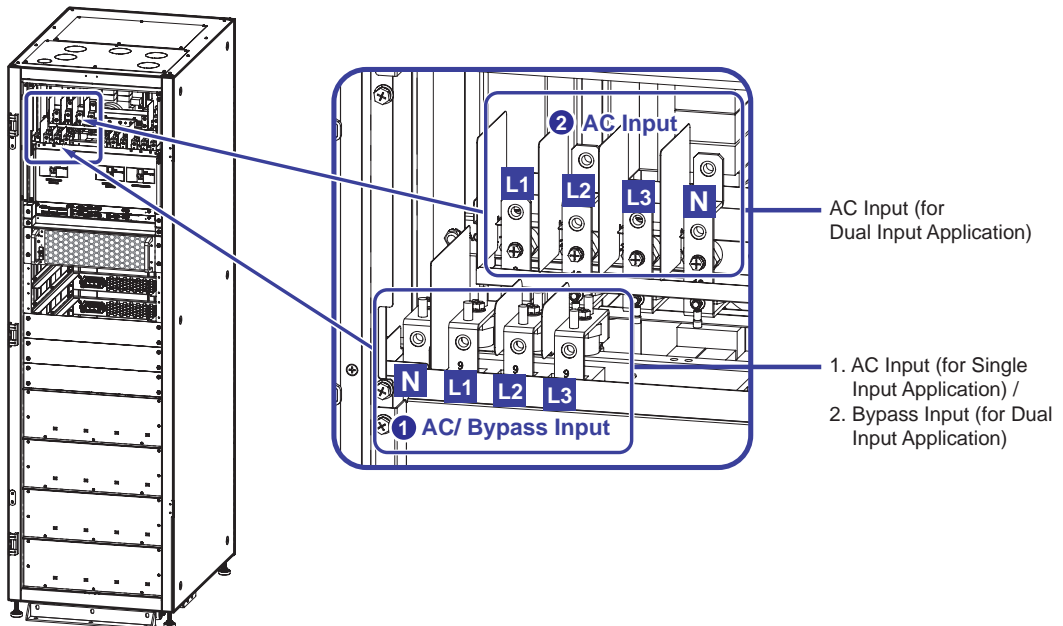

(Figure 5-10: Wiring Terminals_ AC/ Bypass Input & AC Input)

(Internal View with Door Open and Wiring Terminal Cover Removal)

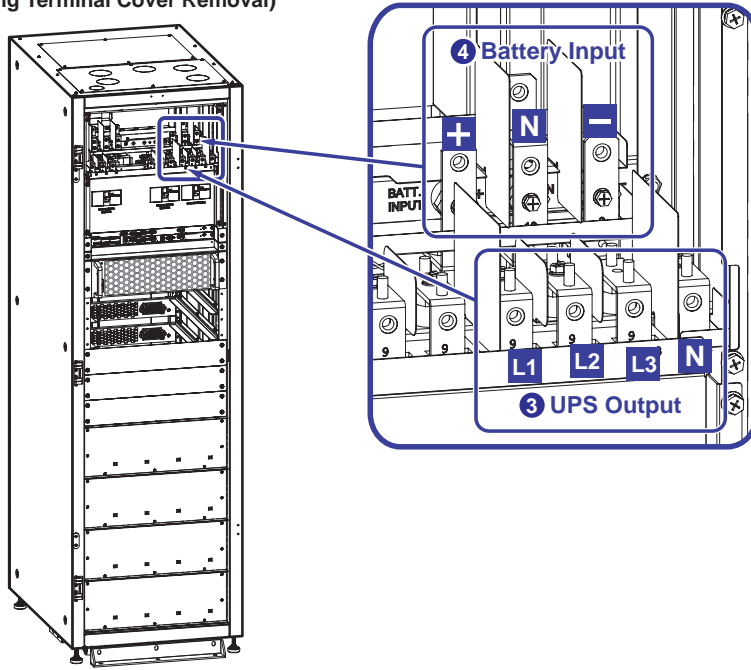

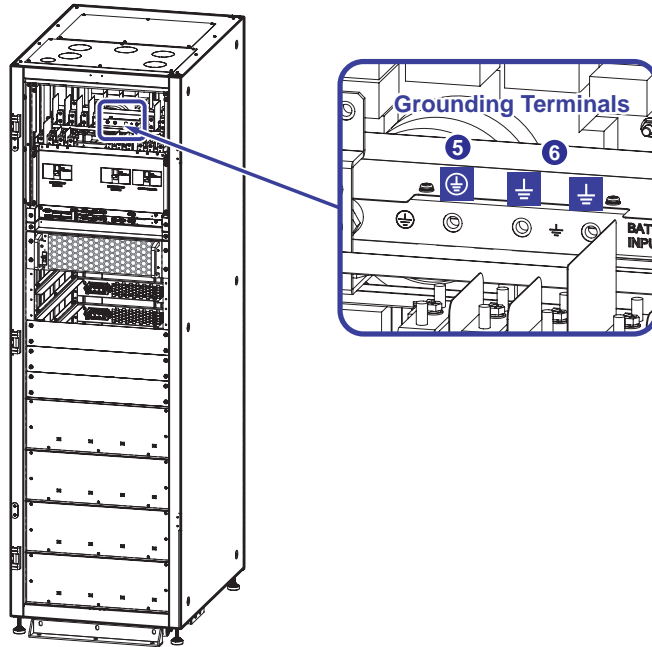

(Figure 5-11: Wiring Terminals_ UPS Output & Battery Input)

(Internal View with Door Open and Wiring Terminal Cover Removal)



(Figure 5-12: Wiring Terminals_ Grounding)

- 4 Refer to the table below and **Figure 5-10 ~ Figure 5-12** for information about the wiring terminals.

No.	Item	Description	Function
1	AC/ Bypass Input Terminals	Include L1/ L2/ L3/ N terminals.	<ul style="list-style-type: none"> Single Input: Connect to the main AC source. Dual Input: Connect to the bypass AC source.
2	AC Input Terminals	Include L1/ L2/ L3/ N terminals.	<ul style="list-style-type: none"> Single Input: There is no need to connect these terminals. Dual Input: Connect to the main AC source.
3	UPS Output Terminals	Include L1/ L2/ L3/ N terminals.	Connect to the critical loads.
4	Battery Input Terminals	Include +/- N terminals.	Connect to the external battery cabinet.
5		Includes one grounding terminal.	For the UPS's protective earthing.
6		Includes two grounding terminals.	Connect to the external battery cabinet and critical loads' grounding terminals ().

- 5 Make sure the Input/ Bypass Breaker (Q1), Manual Bypass Breaker (Q2) and Output Breaker (Q3) are in the **OFF** position. Please see **Figure 2-5** for the breakers' location.
- 6 Make sure that each external battery cabinet's breaker is in the **OFF** position. If there are battery modules (optional) installed inside the UPS, please pull every battery module at least 10cm out of its battery module slot to avoid electric shock.
- 7 Follow **Table 5-2** to select proper input, output and battery cables.
- 8 Connect the main AC source/ output/ external battery cabinet's cables to the UPS. Please refer to **Figure 5-13** and **Figure 5-14**.

Single Input Wiring_ Step 1

(Internal View with Door Open and Wiring Terminal Cover Removal)

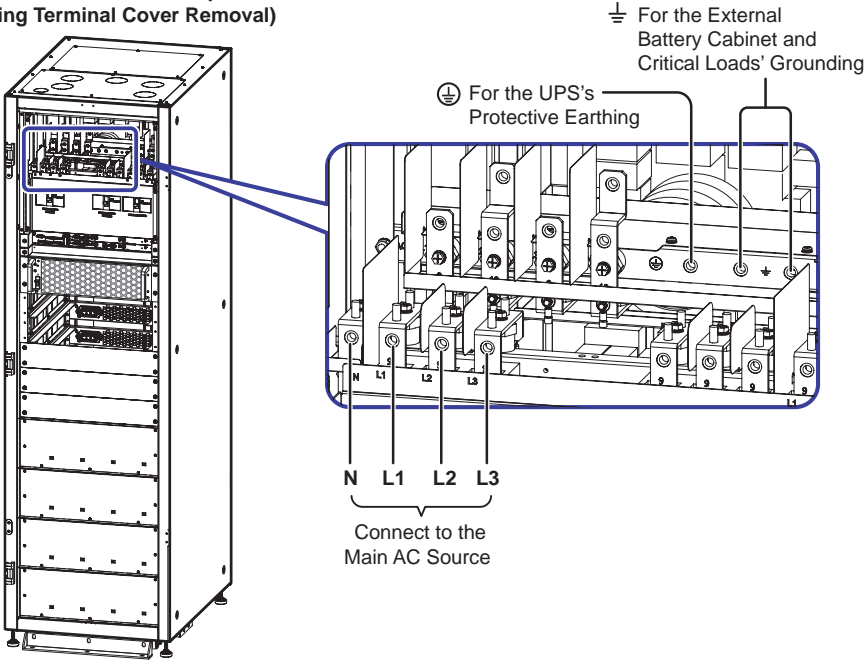

(Figure 5-13: Single Unit Single Input Wiring Diagram_ Step 1)

Single Input Wiring_ Step 2

(Internal View with Door Open and Wiring Terminal Cover Removal)

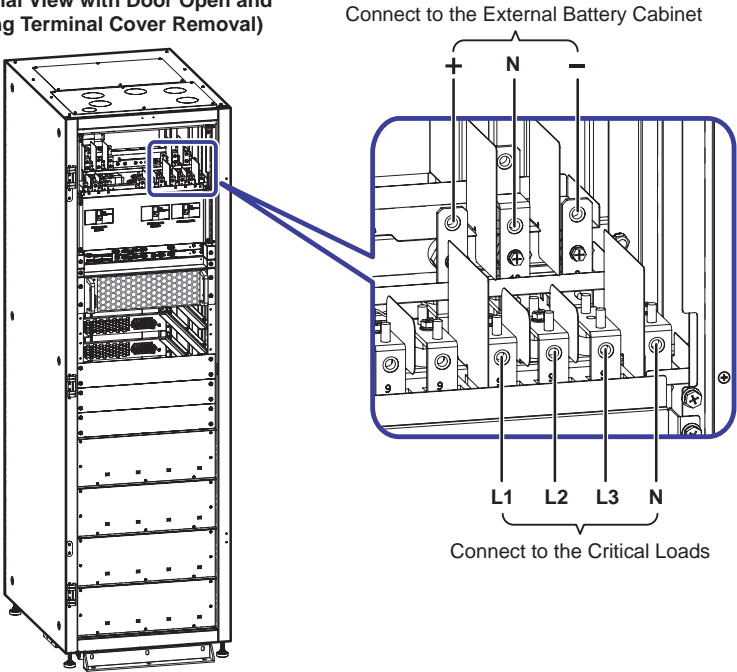

(Figure 5-14: Single Unit Single Input Wiring Diagram_ Step 2)



NOTE:

For single input, the UPS will not work normally if the main AC source's neutral (N) is not firmly connected or not connected to the UPS's Input neutral (N).

- 9 Follow **Figure 5-15** to ground the UPS, the external battery cabinet(s) and the connected critical loads.

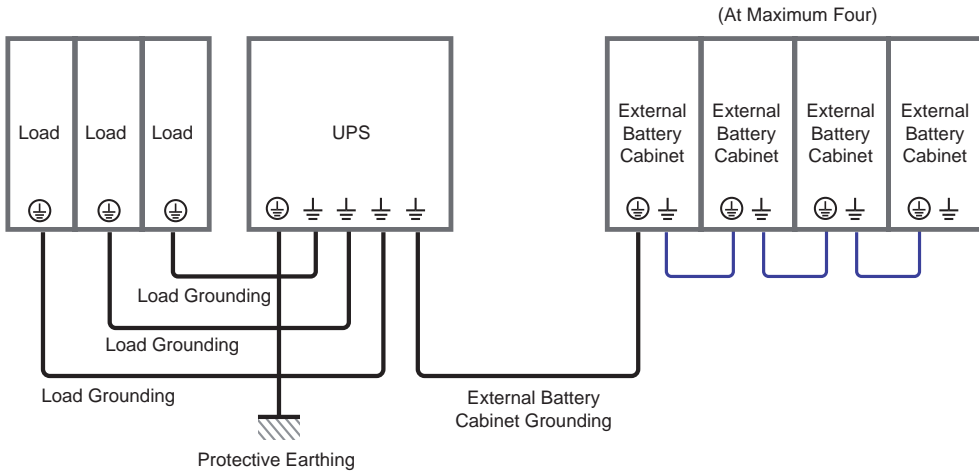

(Figure 5-15: Grounding Diagram_ Single Unit)

• **Dual Input (Single Unit)**

When there are two AC power sources, single unit wiring procedures are as follows.

- 1 Follow **5.5.2 Single Input/ Dual Input Modification** to modify the UPS from single input into dual input.
- 2 Follow the procedures 1 ~ 7 stated in the section of **Single Input (Single Unit)**.
- 3 Connect the main AC source/ bypass AC source/ external battery cabinet/ output's cables to the UPS. Please see **Figure 5-16** and **Figure 5-17**.



NOTE:

For dual input, the UPS will not work normally if the main AC source and bypass AC source's neutral (N) is not firmly connected or not connected to the UPS's Input neutral (N).

- 4 Follow **Figure 5-15** to ground the UPS, the external battery cabinet(s) and the connected critical loads.

Dual Input Wiring_ Step 1

(Internal View with Door Open and Wiring Terminal Cover Removal)

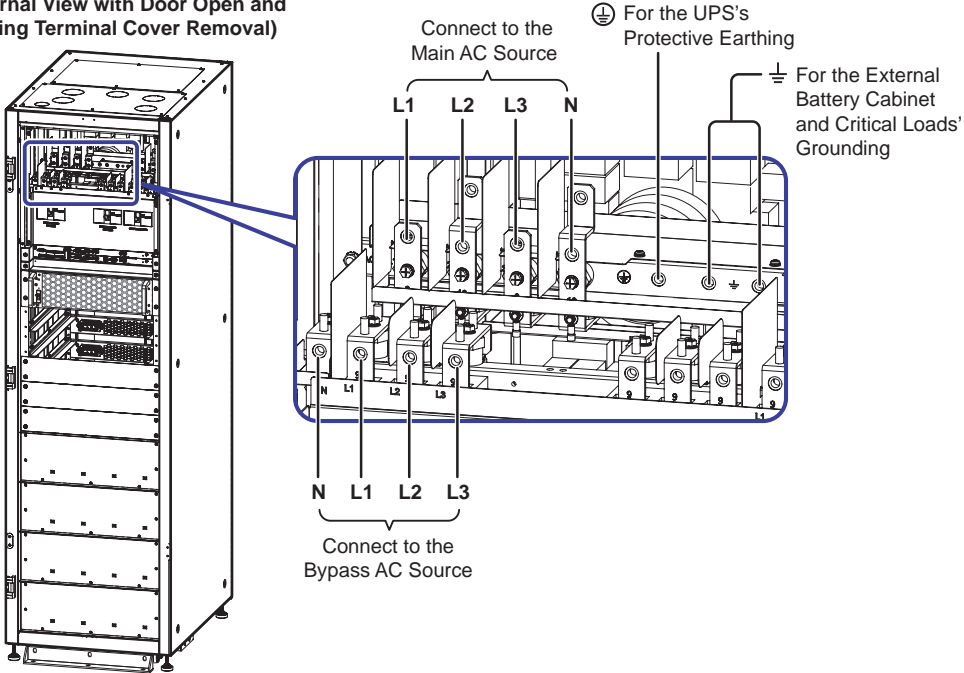

(Figure 5-16: Single Unit Dual Input Wiring Diagram_ Step 1)

Dual Input Wiring_ Step 2

(Internal View with Door Open and Wiring Terminal Cover Removal)

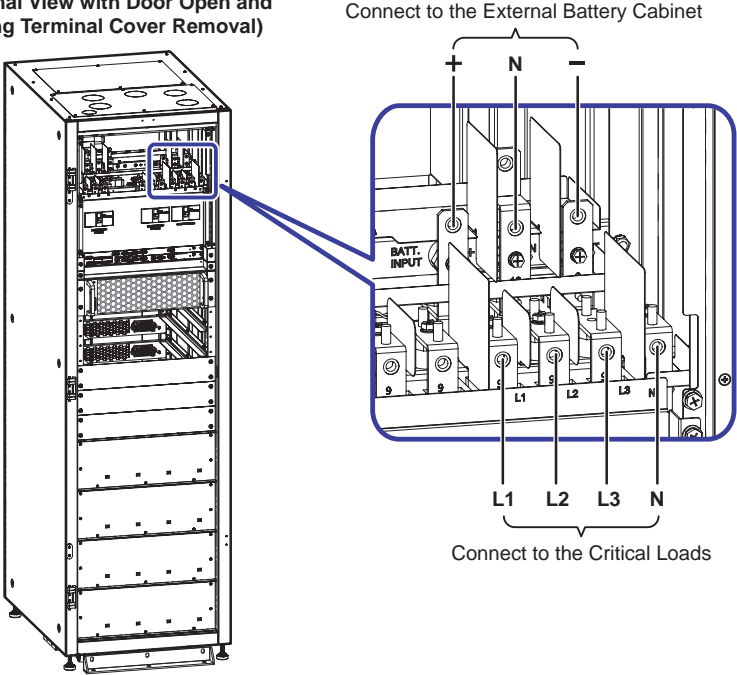

(Figure 5-17: Single Unit Dual Input Wiring Diagram_ Step 2)

5.5.4 Parallel Units Wiring



NOTE:

1. Only authorized Delta engineers or service personnel can perform installation, wiring, panel & cover removal, maintenance and operation. If you want to execute any action mentioned above by yourself, the action must be under the supervision of authorized Delta engineers or service personnel.
2. Only UPSs with the same capacity, voltage and frequency can be paralleled. Please only use the provided parallel cable to parallel the UPS units; otherwise, parallel functions will fail. For UPS parallel information and application, please contact Delta service personnel.
3. When UPSs are paralleled, the length of each unit's input cables plus output cables must be the same. This ensures that the parallel UPSs can equally share the critical loads in bypass mode.
4. The UPS rating voltage is 120/ 208Vac or 127/ 220Vac.
5. The external battery cabinet's rating voltage is $\pm 168\text{Vdc}$.
6. Before wiring, please read **5.5 Wiring** thoroughly.

- **Single Input (Parallel Units)**

When there is only one AC power source, parallel units' wiring procedures are as follows.

- 1 Please follow the procedures 1 ~ 7 stated in the section of **Single Input (Single Unit)**.
- 2 Connect the main AC source/ output/ external battery cabinet's cables to each parallel UPS. Please refer to:

Figure 5-13: Single Unit Single Input Wiring Diagram_ Step 1

Figure 5-14: Single Unit Single Input Wiring Diagram_ Step 2

Figure 5-18: Parallel Units Single Input Wiring Diagram



NOTE:

For single input, the UPS will not work normally if the main AC source's neutral (N) is not firmly connected or not connected to the UPS's Input neutral (N).

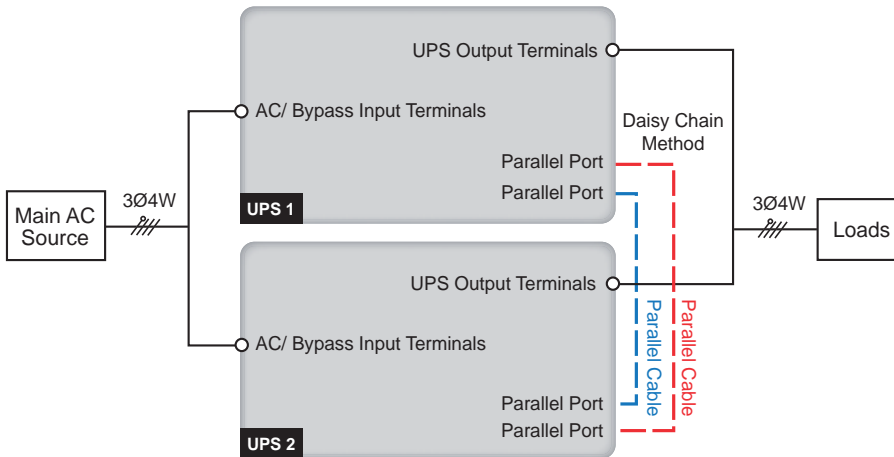

(Figure 5-18: Parallel Units Single Input Wiring Diagram)

- 3 Use the provided parallel cable to connect the parallel ports on the parallel units. Please refer to **Figure 4-3** for the parallel port location.
- 4 Follow **Figure 5-19** to ground the parallel UPS units, external battery cabinet(s) and connected critical loads.

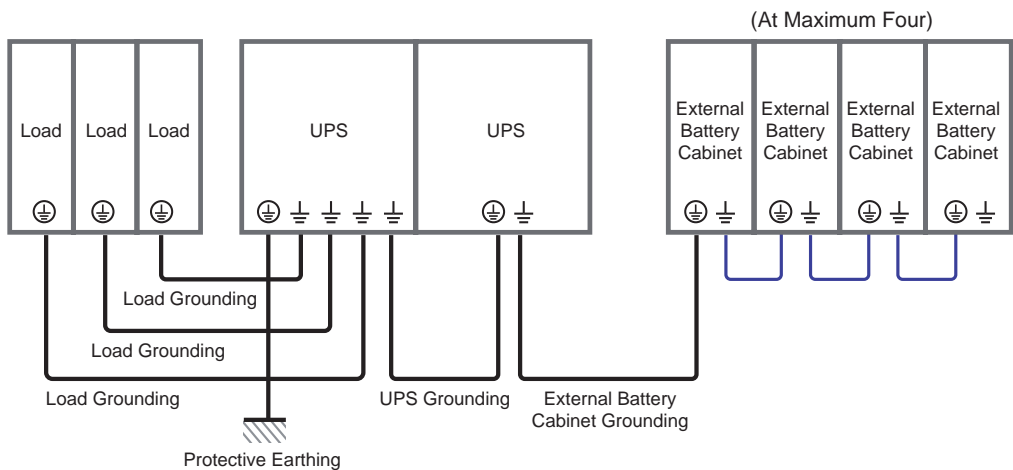

(Figure 5-19: Grounding Diagram_ Parallel Units)



WARNING:

Before start-up of the parallel units, qualified service personnel must set each UPS's 'Parallel Group ID' (1 or 2) and 'Parallel ID' (1 or 2) through the LCD. Otherwise, the parallel UPSs cannot be started. Please refer to **7.10.5 Parallel Setting**.

- **Dual Input (Parallel Units)**

When there are two AC power sources, parallel units' wiring procedures are as follows.

- 1 Follow **5.5.2 Single Input/ Dual Input Modification** to modify the UPS from single input into dual input.
- 2 Refer to the procedures 1 ~ 7 stated in the section of **Single Input (Single Unit)**.
- 3 Connect the main AC source/ bypass source/ output/ external battery cabinet's cables to each parallel UPS. Please refer to:

Figure 5-16: Single Unit Dual Input Wiring Diagram_ Step 1

Figure 5-17: Single Unit Dual Input Wiring Diagram_ Step 2

Figure 5-20: Parallel Units Dual Input Wiring Diagram



NOTE:

For dual input, the UPS will not work normally if the main AC source and bypass AC source's neutral (N) is not firmly connected or not connected to the UPS's Input neutral (N).

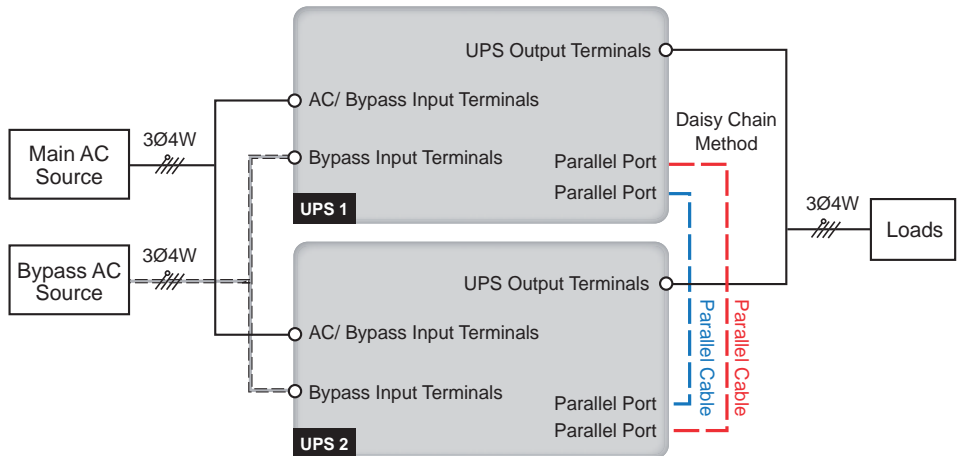

(Figure 5-20: Parallel Units Dual Input Wiring Diagram)

- 4 Use the provided parallel cable to connect the parallel ports on the parallel units. Please refer to **Figure 4-3** for the parallel port location.
- 5 Follow **Figure 5-19** to ground the parallel UPS units, external battery cabinet(s) and connected critical loads.



WARNING:

Before start-up of the parallel units, qualified service personnel must set each UPS's '**Parallel Group ID**' (1 or 2) and '**Parallel ID**' (1 or 2) through the LCD. Otherwise, the parallel UPSs cannot be started. Please refer to **7.10.5 Parallel Setting**.

5.6 External Battery Cabinet Connection Warnings



NOTE:

1. For battery application, you can choose to install (1) the external battery cabinet (at maximum four), (2) the battery modules (optional; at maximum sixteen; at minimum four) or (3) both the external battery cabinet (at maximum four) and the battery modules (optional; at maximum sixteen; at minimum four) for the UPS. For more information, please refer to **5.6 External Battery Cabinet Connection Warnings & 5.9 Battery Module (Optional)**.
 2. A battery can present a risk of electric shock and high short-circuit current. Servicing of batteries and battery cabinets must be performed or supervised by qualified service personnel knowledgeable in batteries, battery cabinets and the required precautions. Keep unauthorized personnel away from batteries and battery cabinets.
 3. Only authorized Delta engineers or qualified service personnel can perform external battery cabinet installation, configuration and wiring. If you want to perform the actions mentioned above by yourself, the actions must be under the supervision of authorized Delta engineers or qualified service personnel.
 4. Before external battery cabinet installation, configuration and wiring, ensure that there is no battery module (optional) installed inside the UPS cabinet. For battery module information, please refer to **5.9 Battery Module (Optional)**.
 5. If there are battery modules (optional) installed inside the UPS, please pull every battery module at least 10cm out of its battery module slot to avoid electric shock.
 6. Common battery is only applicable to the external battery cabinet (at maximum four) but not to the battery modules (optional). For common battery application, please refer to **3.4 Common Battery (Only for Parallel UPSs Connecting to the Same External Battery Cabinet(s))**.
 7. Turn off the UPS and cut off the AC power source before performing battery/ battery cabinet connection, wiring and replacement.
- Only use the same type of batteries from the same supplier. Never use old, new and different Ah batteries at the same time.
 - The number of batteries must meet UPS requirements.
 - Do not connect the batteries in reverse.
 - The default number of batteries is 28 PCS of 12V batteries connected in string, and you should connect the external battery cabinet's neutral to the middle 14th and 15th batteries. You should use battery cables to connect the external battery cabinet with the '+', '-' and 'N' terminals marked on the UPS. Please refer to **Figure 5-21**.

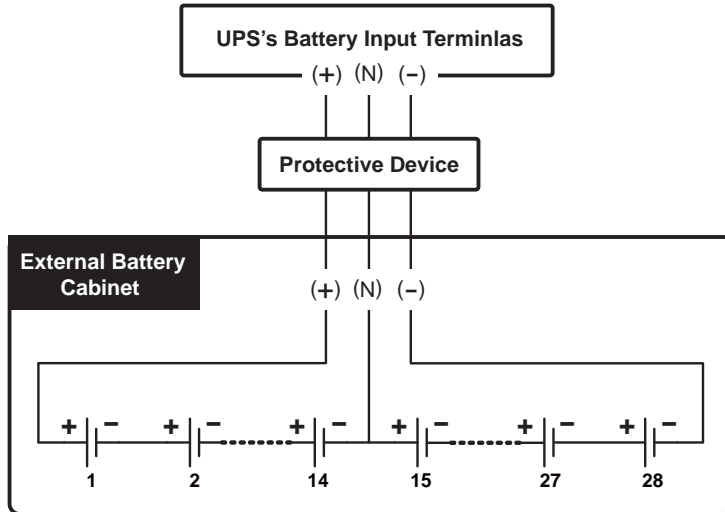

(Figure 5-21: External Battery Cabinet Connection)

- For the external battery cabinet's grounding information, please refer to:
 - Figure 5-15: Grounding Diagram_ Single Unit**
 - Figure 5-19: Grounding Diagram_ Parallel Units**
- Please follow your UPS's rating to install an appropriate protective device for the external battery cabinet. The external battery cabinet's protective device must be planned and designed by qualified service personnel. The protective device should be either an isolated switch connected in series with a DC fuse or a 3-pole DC circuit breaker; please refer to **Table 5-3**. When choosing the external battery cabinet's protective device, please take the following factors into consideration: (1) over current between the UPS and battery circuit, (2) short circuit, (3) wire/ cable material, and (4) local electrical regulations. If you have any questions about the external battery cabinet's protective device, please contact Delta service personnel. Please refer to **Figure 5-22 ~ Figure 5-23** for the installation of the external battery cabinet's protective device.
- The protective device's capacity must be larger than the current shown in **Table 5-3**.

Table 5-3: External Battery Cabinet's Protective Device (Default Battery Q'ty: 28 PCS)

UPS Capacity	Power Module Q'ty	Protective Device's Current	Protective Device's Voltage
15kVA/ 15kW	1+1	60A	1. DC fuse \geq 250Vdc 2. 3-pole DC circuit breaker (per pole voltage \geq 250Vdc)
30kVA/ 30kW	2+1	125A	
45kVA/ 45kW	3+1	175A	
60kVA/ 60kW	4+1	225A	

**NOTE:**

1. **Table 5-3** is based on 28 PCS batteries (default). If you install different number of batteries, please contact Delta service personnel for protective device's current and voltage.
2. The above-mentioned DC fuse and DC circuit breaker are optional. If you want to buy any of them, please contact Delta service personnel.
3. Battery protective device must be DC type only. Please contact Delta regional office for information about the exact sizing of the DC fuse or DC circuit breaker according to your on-site conditions.

1. **Option 1: An isolated switch connected in series with a DC fuse (voltage \geq 250Vdc)**

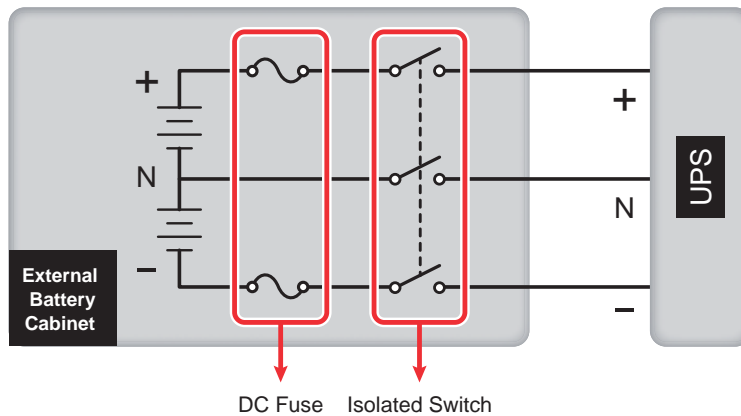

(Figure 5-22: Installation of an Isolated Switch Connected in Series with a DC Fuse)

2. **Option 2: A 3-pole DC circuit breaker (per pole voltage \geq 250Vdc)**

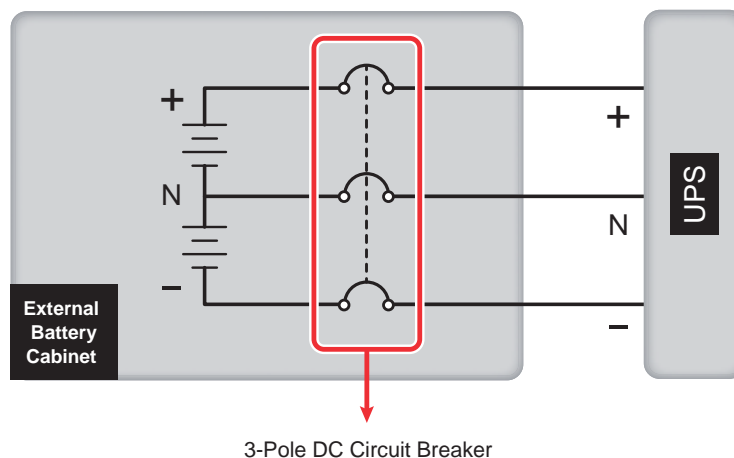

(Figure 5-23: Installation of a 3-Pole DC Circuit Breaker)

- If you need to parallel multiple units of external battery cabinets, please contact Delta service personnel for relevant information. To extend backup time, you can parallel up to four units of external battery cabinets to the UPS. Please note that (1) the number of batteries in each of the parallel external battery cabinets and (2) the cable length of each string of the batteries must be the same.
- If you choose to install both the battery modules (optional; at maximum sixteen; at minimum four) and the external battery cabinet (at maximum four), please ensure that the brand and type of every battery are the same.
- Use a voltage meter to measure whether the total voltage, after the external battery cabinet connection, is around 12.5Vdc × the total number of batteries.
- To ensure that the batteries are fully charged, please charge the batteries at least 8 hours before initial use of the UPS. The charging procedures are as follows.
 1. Connect the UPS to the AC power source and the external battery cabinet. Please refer to **5. Installation and Wiring**.
 2. Follow **6. Operation** to turn on the UPS and the external battery cabinet. After the UPS is turned on, the unit will automatically charge the batteries.



WARNING:

You can connect the critical loads to the UPS only after the batteries are fully charged. This guarantees that the UPS can provide sufficient backup power to the critical loads connected when a power failure occurs.

- **Battery parameters**

No.	Item	Description
1	Charge Voltage	Float charge voltage: ± 190Vdc (default)
		Equalized charge voltage: ± 196Vdc (default)
2	Charge Current	Default: ± 1.5A (per power module)
		Minimum: ± 4A
		Maximum: ± 6A (15kVA) / ± 12A (30kVA) / ± 18A (45kVA) / ± 24A (60kVA) (per power module's Max. current: 6A)
3	Low Battery Shutdown Voltage	±140Vdc (default)
4	The Number of Batteries	12V × 28 PCS (default)

**NOTE:**

1. You can adjust the charge current from 4A to the maximum in increments of 1A
2. If you need to modify the default charge current setting and default low battery shutdown setting, please contact your local dealer or service personnel.
3. For battery selection, installation and replacement, please contact your local dealer or customer service.
4. The number of batteries that you set up via the LCD must be the same as that of on-site installation; otherwise, the batteries will be over charged, not fully charged or even seriously damaged.

- **External Battery Cabinet Alarm**

When any external battery cabinet connected to the UPS has the following problems, the UPS system will sound an alarm. Please see the table below.

No.	External Battery Cabinet Status	Alarm
1	Battery Abnormal - Reversed	Sounds 50ms every second.
2	Battery Ground Fault	Sounds 50ms every second.
3	Battery Over Temperature	Sounds 50ms every second.
4	Battery Under Temperature	Sounds 50ms every second.
5	Battery Breaker Off	Sounds 50ms every 3 seconds.
6	Battery Disconnected (Missing)	Sounds once every second.
7	Battery Over Charged	Long beep.
8	Battery Test Fail	Sounds 50ms every second.
9	Battery End of Discharge Imminent	Sounds 50ms every second.
10	Battery End of Discharge	Long beep.
11	Battery Life Time Expired	Sounds 50ms every 3 seconds.

5.7 STS Module

The hot swappable STS module has been installed inside the UPS in the Delta factory before shipment. Please see the following for its location (see **Figure 5-24**).

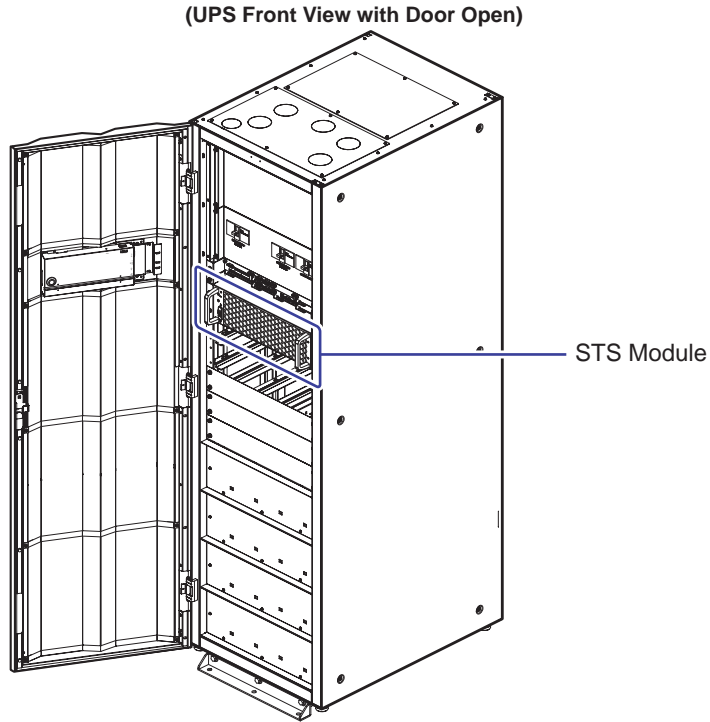

(Figure 5-24: STS Module Location)

For STS module illustration, please refer to **Figure 5-25**.

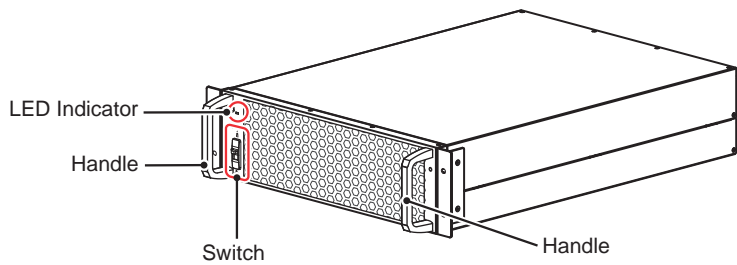

(Figure 5-25: STS Module)

5.7.1 STS Module Installation

The STS module has been installed inside the UPS in the Delta factory before shipment. If the STS module is removed for some reasons and you want to re-install it, please follow the steps below.



NOTE:

1. Only qualified service personnel can perform the following STS module installation procedures.
2. The STS module is heavy (> 46.3 lb (> 21 kg)). At least two people are required for handling.

- 1 Confirm that (1) the STS module's switch is in the lower position () and (2) the switch cannot be moved down anymore.

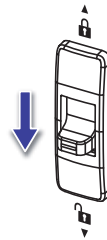

(Figure 5-26: Turn the STS Module's Switch to the Lower Position until the Switch Cannot be Moved down Anymore)

- 2 Insert the STS module into the unoccupied STS module slot until it snaps into place. Two people are required.

(UPS Front View with Door Open)

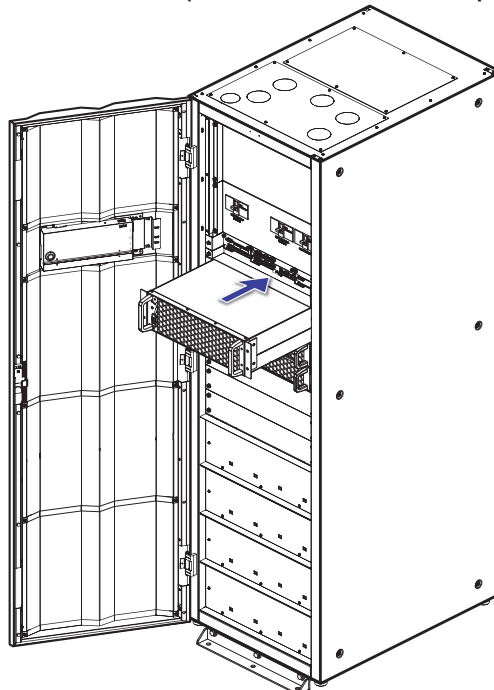

(Figure 5-27: Insert the STS Module into the UPS)

- 3 Re-install the four screws (removed during the STS module removal process) to firmly fix the STS module's bracket ears on the UPS cabinet.

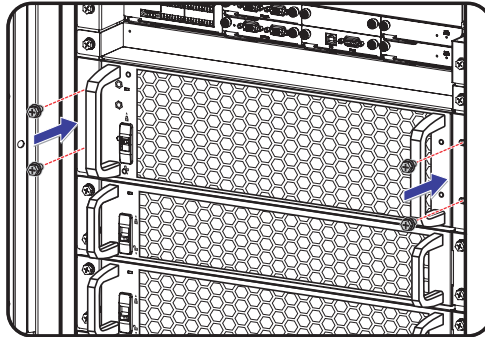

(Figure 5-28: Fix the STS Module on the UPS)

- 4 (1) Turn the STS module's switch to the upper position () and (2) confirm that the switch cannot be moved up anymore.

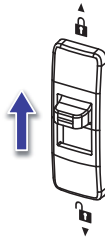

(Figure 5-29: Turn the STS Module's Switch to the Upper Position until the Switch Cannot be Moved up Anymore)

5.7.2 STS Module Removal



NOTE:

1. Only qualified service personnel can perform the following STS module removal procedures.
2. The STS module is heavy (> 46.3 lb (> 21 kg)). At least two people are required for handling.

- 1 (1) Turn the STS module's switch to the lower position (), (2) confirm that the switch cannot be moved down anymore and (3) wait until the STS module's LED indicator becomes off.

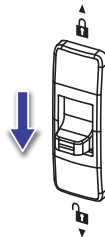

(Figure 5-30: Turn the STS Module's Switch to the Lower Position until the Switch Cannot be Moved down Anymore)

- 2) Unscrew the four screws shown in **Figure 5-31**.

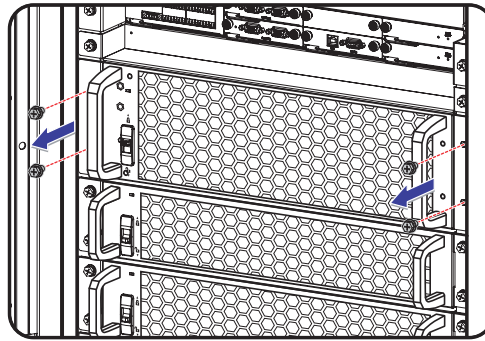

(Figure 5-31: Remove the Four Screws)

- 3) Pull out the STS module from the slot (two people are required) (see **Figure 5-32**). When the STS module cannot be pulled out any more, press the lock (see **Figure 5-33**) on the left side of the STS module in order to continuously pull out the module from the UPS cabinet.

(UPS Front View with Door Open)

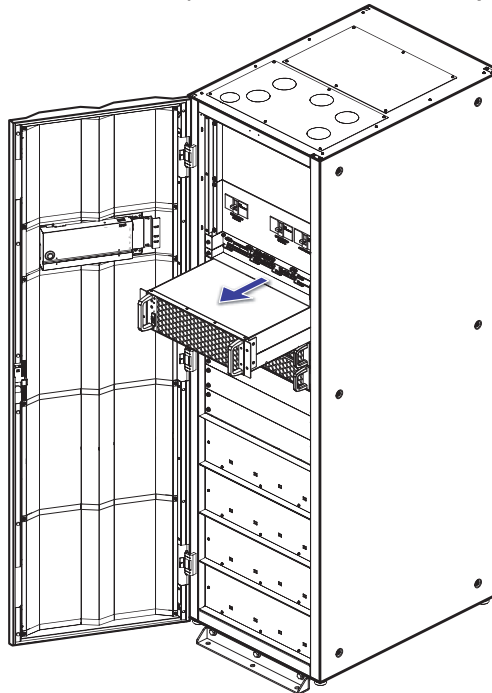

(Figure 5-32: Remove the STS Module from the UPS Cabinet)

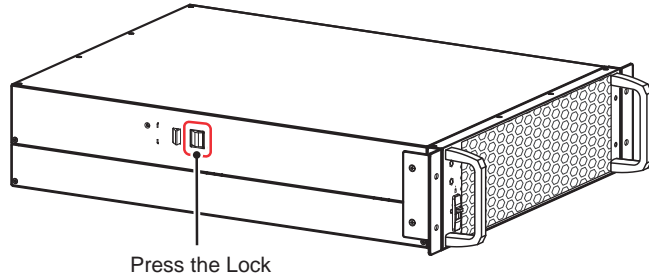

(Figure 5-33: Press the Lock of the STS Module)

5.7.3 STS Module's LED Indicator

The STS module's LED indicator shows its operation status. Please refer to the following table.

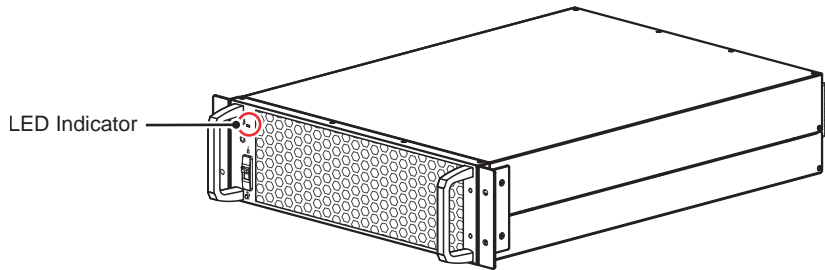



(Figure 5-34: STS Module's LED Indicator)

LED Indicator	Description
OFF	The STS module is OFF.
ON (yellow)	The STS module is working in bypass mode, ECO mode, or energy recycle mode.
Flashing (yellow)_ on for 0.3 second and off for 3 seconds	The STS module is abnormal.



NOTE:

In bypass mode, if you turn the STS module's switch to the lower position (), the STS module will shut down its output and its LED indicator will be off. 

5.8 Power Module (Optional)

The power module is optional (not included in the package of the UPS). It is hot swappable and each capacity is 15kVA/ 15kW. Please follow UPS capacity to install appropriate number of power modules.

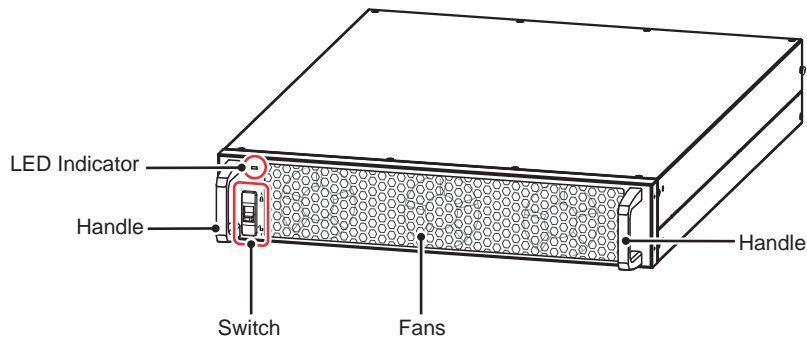

(Figure 5-35: Power Module (Optional))

Please see the table below for the power module's packing list.

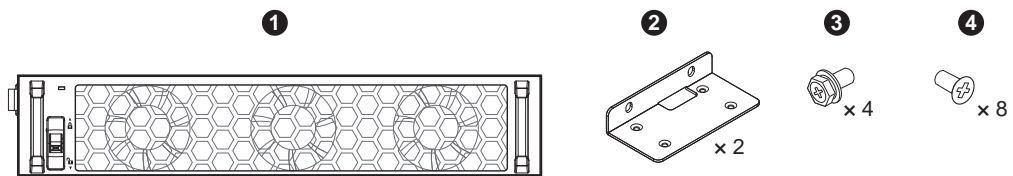

Table 5-4: Power Module Packing List

No.	Item	Q'ty
①	Power Module	1 PC
②	Bracket Ear	2 PCS
③	M6 Screw	4 PCS
④	M4 Screw	8 PCS

5.8.1 Power Module Installation

After following **5.4 Fixing the UPS** to firmly fix the UPS in the designated installation area, follow the following steps to install the power modules into the UPS.



WARNING:

1. Only qualified service personnel can perform the following installation procedures.
2. The power module is heavy (> 46.3 lb (> 21 kg)). At least two people are required for handling.
3. Please follow UPS capacity to install appropriate number of power modules.

DPH Series UPS_ 15~ 60kVA				
UPS Capacity	15kVA/ 15 kW	30kVA/ 30 kW	45kVA/ 45 kW	60kVA/ 60 kW
Power Module Q'ty	1+1	2+1	3+1	4+1

4. To take the center of gravity into consideration, please install the power modules from the top layer of the power module slot to the bottom layer of the power module slot in sequence.

- 1 Confirm that (1) the power module's switch is in the lower position () and (2) the switch cannot be moved down anymore.

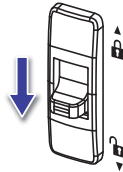

(Figure 5-36: Turn the Power Module's Switch to the Lower Position until the Switch Cannot be Moved down Anymore)

- 2 Take out the two bracket ears, four M6 screws and eight M4 screws from the power module's package.
- 3 Use the provided eight M4 screws to fix the provided two bracket ears on the two sides of the power module. Please refer to **Figure 5-37**.

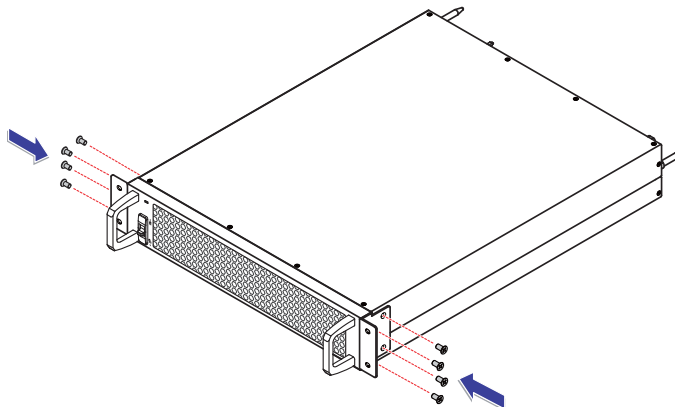

(Figure 5-37: Install the Two Bracket Ears)

- 4 There are five power module slots (see **Figure 5-38**). The top two slots are without covers but the bottom three slots are with covers. Each slot cover has four screws. If you need to insert the power module into a slot that has a cover, please remove the cover's four screws first.

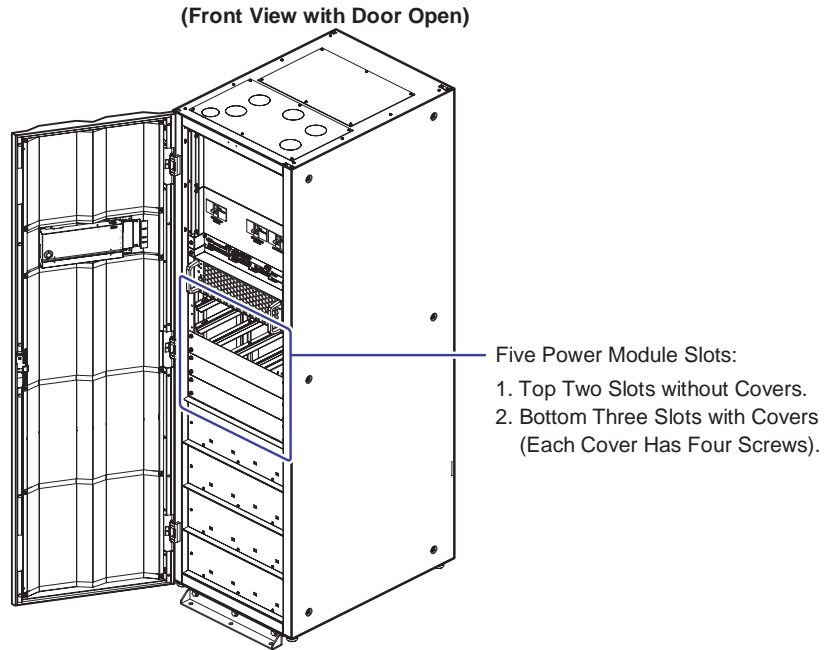

(Figure 5-38: Location of Power Module Slots and Covers)

- 5 Insert the power module into the power module slot until it snaps into place. Two people are required. Please refer to **Figure 5-39**.



NOTE:

To take the center of gravity into consideration, please install the power modules from the top layer of the power module slot to the bottom layer of the power module slot in sequence.

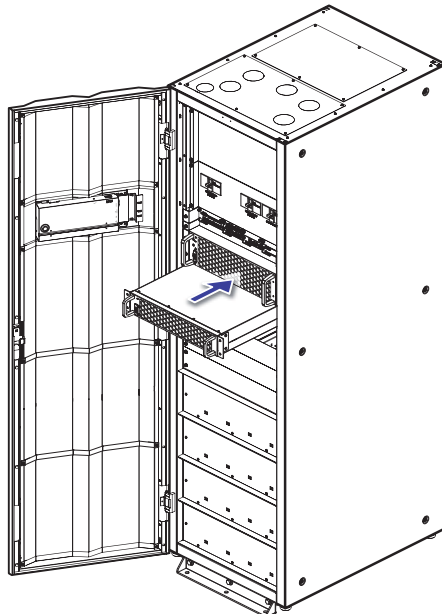

(Figure 5-39: Insert the Power Module into the UPS)

- 6 Use the provided four M6 screws to firmly fix the power module on the UPS. Please refer to **Figure 5-40**.

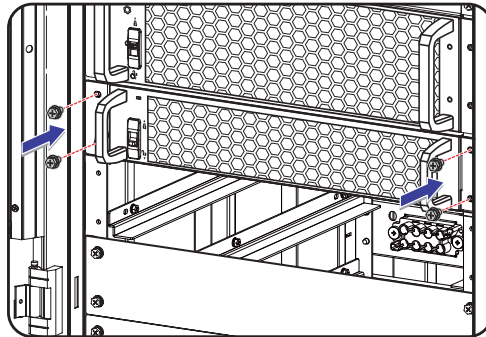

(Figure 5-40: Fix the Power Module on the UPS)

- 7 (1) Turn the power module's switch to the upper position () and (2) confirm that the switch cannot be moved up anymore.

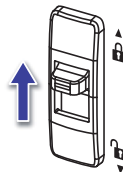

(Figure 5-41: Turn the Power Module's Switch to the Upper Position until the Switch Cannot be Moved up Anymore)

5.8.2 Power Module Removal



WARNING:

1. Before removing any power module, make sure that the remaining power modules can support the connected critical loads.
2. Only qualified service personnel can perform the following removal procedures.
3. The power module is heavy (> 46.3 lb (> 21 kg)). At least two people are required for handling.

- 1 Turn the power module's switch to the lower position () and confirm that the switch cannot be moved down anymore. After that, the power module will start discharging. After discharging, the power module's LED indicator will be off.

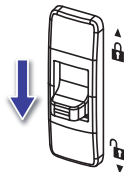

(Figure 5-42: Turn the Power Module's Switch to the Lower Position until the Switch Cannot be Moved down Anymore)

- 2 Use a screwdriver to remove the four screws shown in **Figure 5-43**.

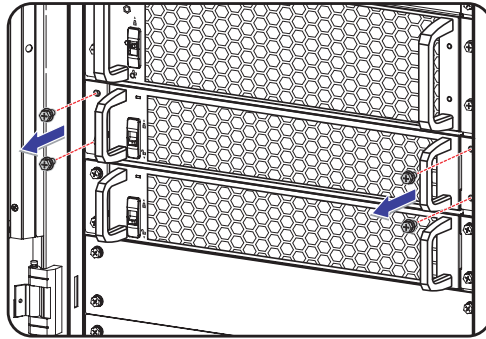

(Figure 5-43: Remove the Four Screws)

- 3 Pull out the power module from the slot (two people are required) (see **Figure 5-44**). When the power module cannot be pulled out any more, press the lock (see **Figure 5-45**) on the left side of the power module in order to continuously pull out the module from the UPS cabinet.

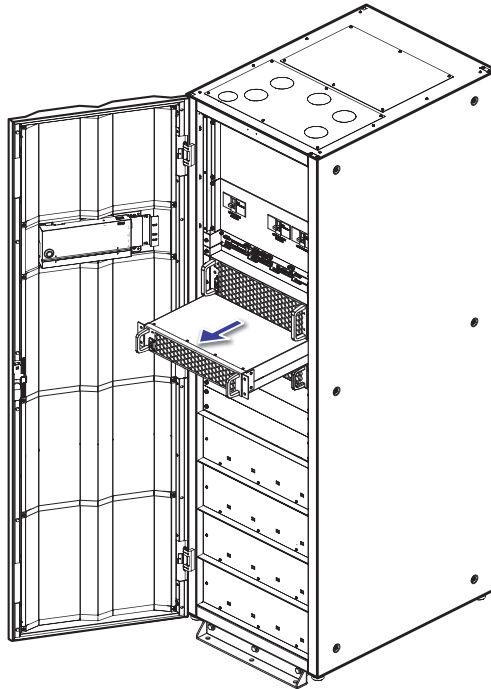

(Figure 5-44: Remove the Power Module)

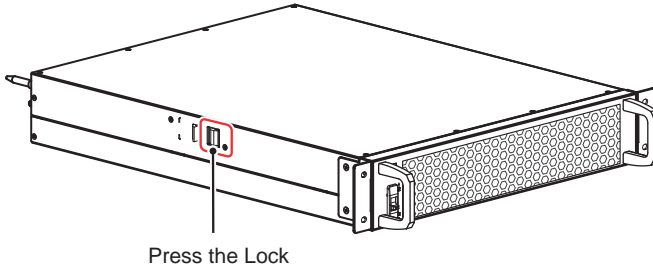

(Figure 5-45: Press the Lock of the Power Module)

5.8.3 Power Module's LED Indicator

The power module's LED indicator shows its operation status. Please refer to the following table.

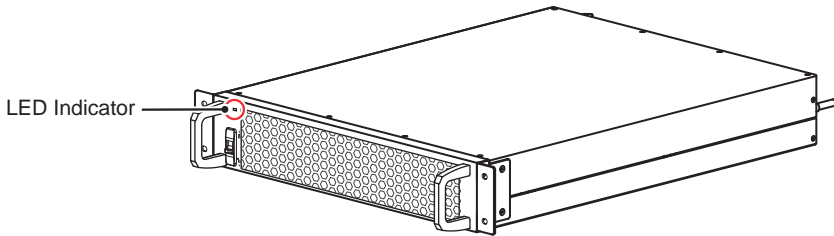

(Figure 5-46: Power Module's LED Indicator)

LED Indicator	Description
OFF	The power module is OFF.
ON (green)	<ol style="list-style-type: none"> 1. The power module is running in online mode or in battery mode. 2. The power module's inverter starts up. 3. The power module's PFC starts up.
Flashing (green)_ on for 2 seconds and off for 1 second	The power module is under discharging process.
Flashing (green)_ on for 0.3 second and off for 3 seconds	The power module is abnormal.



NOTE:

In online mode, if you turn the power module's switch into the lower position (), the power module will shut down its output and discharge the DC BUS voltage until the voltage reaches to a safety level. After that, the power module's LED indicator will be off.

5.9 Battery Module (Optional)

The battery module is hot swappable and optional (not included in the package of the UPS). Please follow on-site requirements to install appropriate number of battery modules.

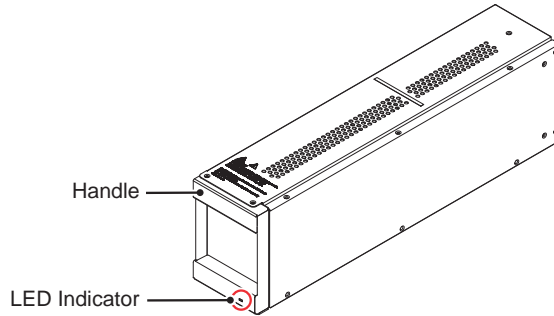

(Figure 5-47: Battery Module (Optional))

Please see the table below for the battery module's packing list.

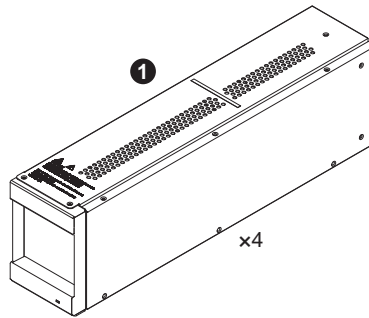

Table 5-5: Battery Module Packing List

No.	Item	Q'ty
①	Battery Module	4 PCS

5.9.1 Battery Module Warnings

- The UPS has four layers of battery module slots. Each battery module slot has a cover with seven screws. Please see **Figure 5-48** for the location of the battery module slots.

Please note that a layer of battery module slot must be fully installed four battery modules.

To take the center of gravity into consideration, please install the battery modules from the bottom layer of the battery module slot to the top layer of the battery module slot in sequence.

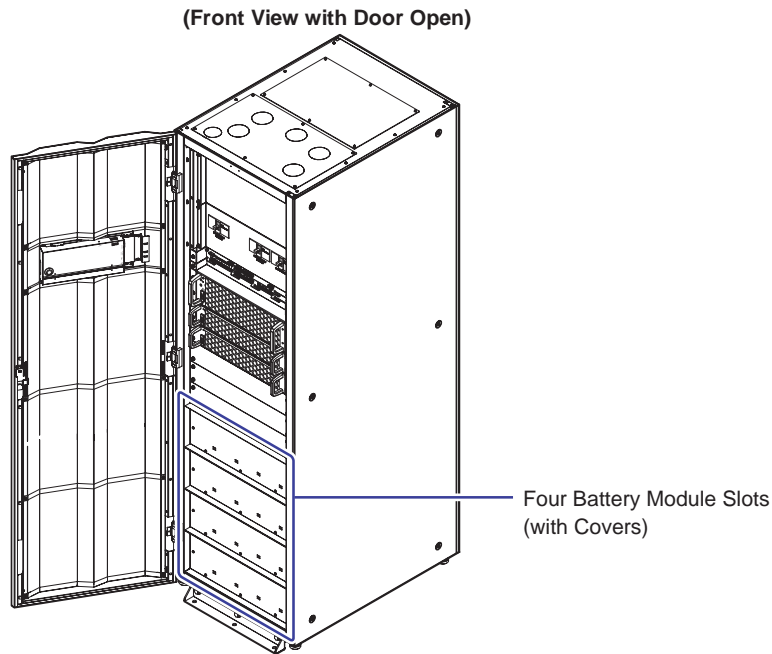

(Figure 5-48: Location of Four Battery Module Slots (with Covers))

- One battery module package includes four battery modules (see **Table 5-5**). For battery module application, you must install the four battery modules into the same layer of the battery module slot. Do not only install one battery module in one battery module slot or install the four battery modules into different layers of the battery module slots.
- For battery application, you can choose to install (1) the external battery cabinet (at maximum four), (2) the battery modules (optional; at maximum sixteen; at minimum four) or (3) both the external battery cabinet (at maximum four) and the battery modules (optional; at maximum sixteen; at minimum four) for the UPS. For more information, please refer to **5.6 External Battery Cabinet Connection Warnings** and **5.9 Battery Module (Optional)**.

- Common battery is only applicable to the external battery cabinet (at maximum four) but not to the battery modules (optional). For common battery application, please refer to **3.4 Common Battery (Only for Parallel UPSs Connecting to the Same External Battery Cabinet(s))**.
- In battery mode, do not hot-swap any battery module.
- Please follow the table below to (1) install appropriate number of battery modules and (2) refer to relevant data.

Table 5-6: Battery Module Q'ty & Relevant Data

DPH Series UPS_ 15 ~ 60kVA Battery Module Data				
UPS Capacity	15kVA/ 15 kW	30kVA/ 30 kW	45kVA/ 45 kW	60kVA/ 60 kW
Power Module Q'ty	1+1	2+1	3+1	4+1
Minimum Battery Module Q'ty	8	12	12	16
Battery Ah	18 Ah	27 Ah	27 Ah	36 Ah
Maximum Charge Current	4 A	6 A	6 A	8 A

- After battery module installation, use a voltage meter to measure whether the total battery voltage is correct or not.
- Electric Shock Hazard!

The bus bars at the rear of the UPS are energized with dangerous DC voltage coming from the battery modules. Before removing the rear panel of the UPS, please pull every battery module at least 10cm out of its battery module slot to avoid electric shock.

5.9.2 Battery Module Installation

After following **5.4 Fixing the UPS** to firmly fix the UPS in the designated installation area, follow the following steps to install the battery modules into the UPS.



WARNING:

1. In battery mode, do not hot-swap any battery module.
2. Only qualified service personnel can perform the following battery module installation procedures.
3. Before battery module installation, please read **5.9.1 Battery Module Warnings** thoroughly.
4. The battery module is heavy (> 52.2 lb (> 23.7 kg)). At least two people are required for handling.

- 1 Open the UPS's front door and follow on-site requirements to decide how many covers of the battery module slots that you need to remove (each cover has 7 screws). Please see **Figure 5-49**.

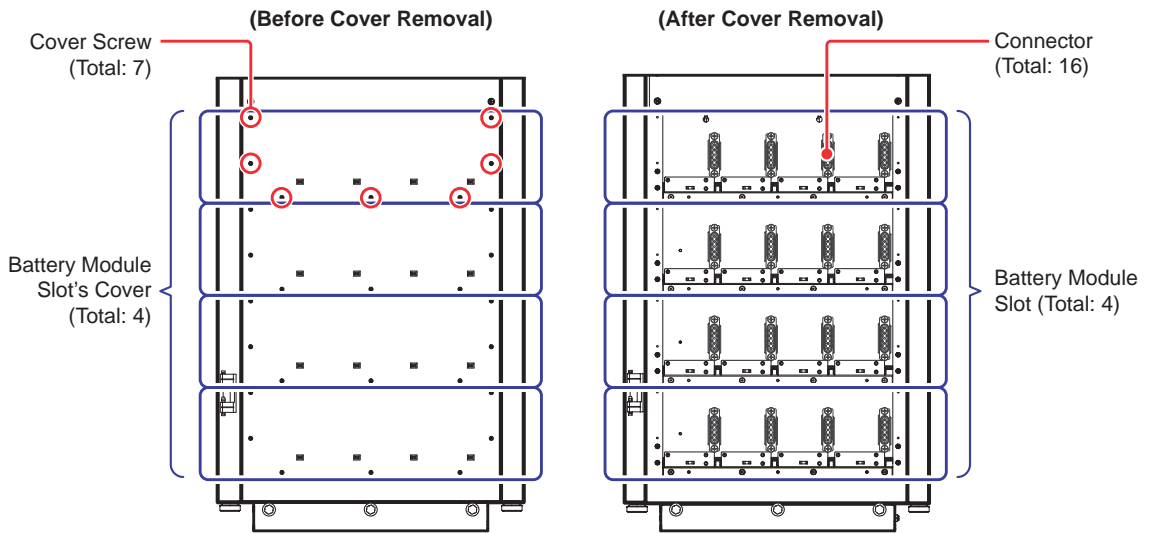

(Figure 5-49: Remove the Cover(s) of the Battery Module Slot(s))

- 2 To take the center of gravity into consideration, please install the battery modules from the bottom layer of the battery module slot to the top layer of the battery module slot in sequence.

Hold the battery module's handle (see **Figure 5-50**), aim the connector locating inside the battery module slot (see **Figure 5-49** for the connector's location), and insert the battery module into the rails until the battery module is well connected with the connector.

One battery module package includes four battery modules (see **Table 5-5**). You must install the four battery modules into the same layer of the battery module slot. Do not only install one battery module in one battery module slot or install the four battery modules into different layers of the battery module slots.

Please follow on-site requirements to decide how many battery modules that you need to install (please refer to **Table 5-6**). Pay attention that a layer of battery module slot must be fully installed four battery modules.

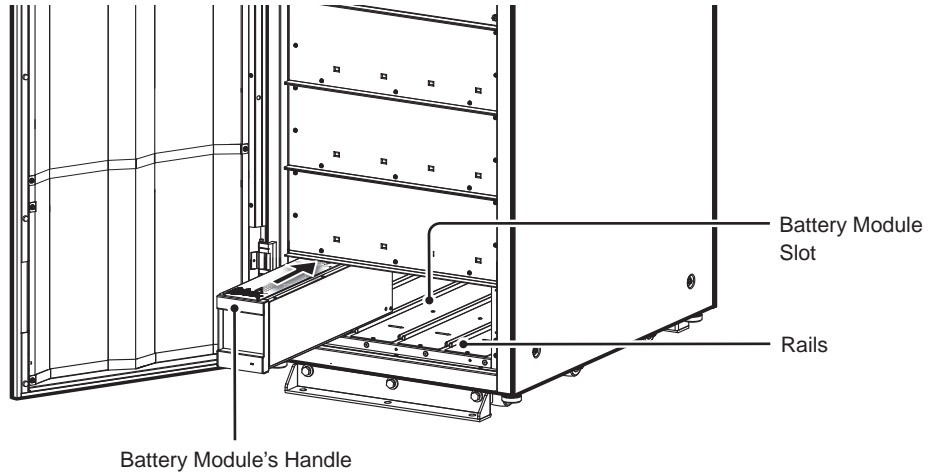

(Figure 5-50: Insert the Battery Module into the Battery Module Slot)

- 3) Ensure that a layer of battery module slot is fully installed four battery modules. After confirmation, re-install the battery module slot's cover (each cover has 7 screws). Please refer to **Figure 5-51**.

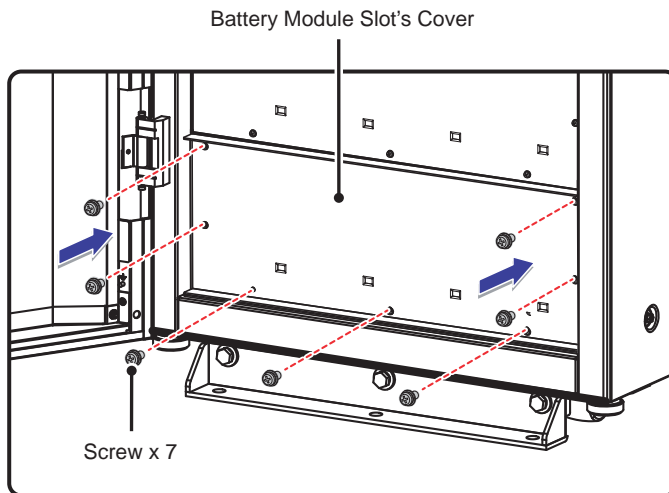

(Figure 5-51: Re-install the Cover of the Battery Module Slot)

5.9.3 Battery Module Removal



NOTE:

1. In battery mode, do not hot-swap any battery module.
2. Only qualified service personnel can perform the following battery module removal procedures.
3. Removal of the battery module(s) will let your critical loads not be protected once a power event occurs. Please ensure that your critical loads are safely shut down before removal of the battery module(s).
4. The battery module is heavy (> 52.2 lb (> 23.7 kg)). At least two people are required for handling.

- 1 Follow on-site requirements to decide how many covers of the battery module slots that you need to remove (each cover has 7 screws). Please see **Figure 5-52**.

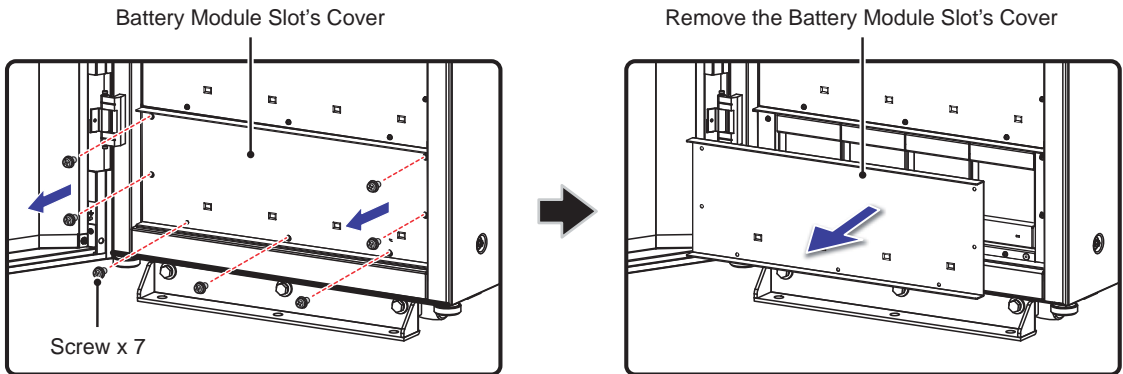

(Figure 5-52: Remove the Cover of the Battery Module Slot)

- 2 A layer of the battery module slot accommodates four battery modules. Take out the battery modules one by one. One person holds the battery module's handle and two persons work together to pull it out of the UPS cabinet.

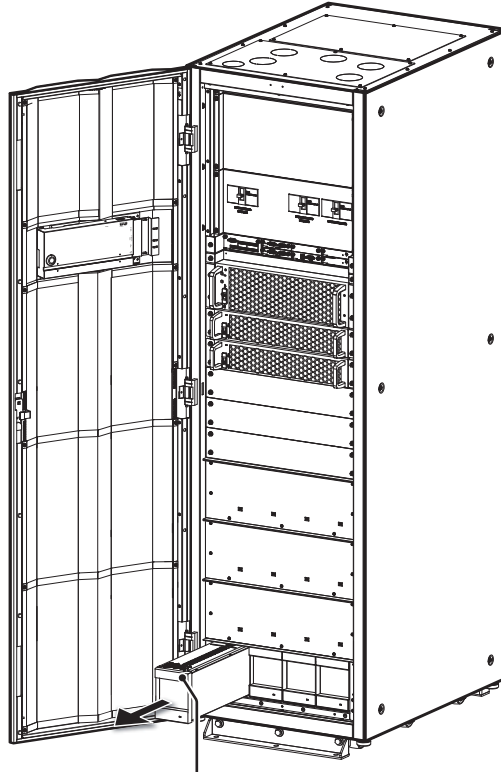

Battery Module's Handle

(Figure 5-53: Remove the Battery Module)

5.9.4 Battery Module's LED Indicator

The battery module's LED indicator is located at the front (see **Figure 5-54**). After a layer of battery module slot is fully installed four battery modules and the cover of the battery module slot is installed, you will see the four battery modules' LED indicators from the cover shown in **Figure 5-55**.

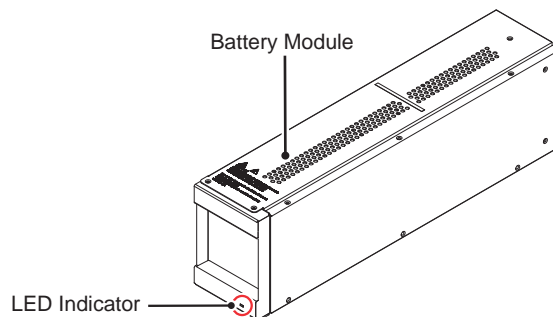

(Figure 5-54: Battery Module's LED Indicator)

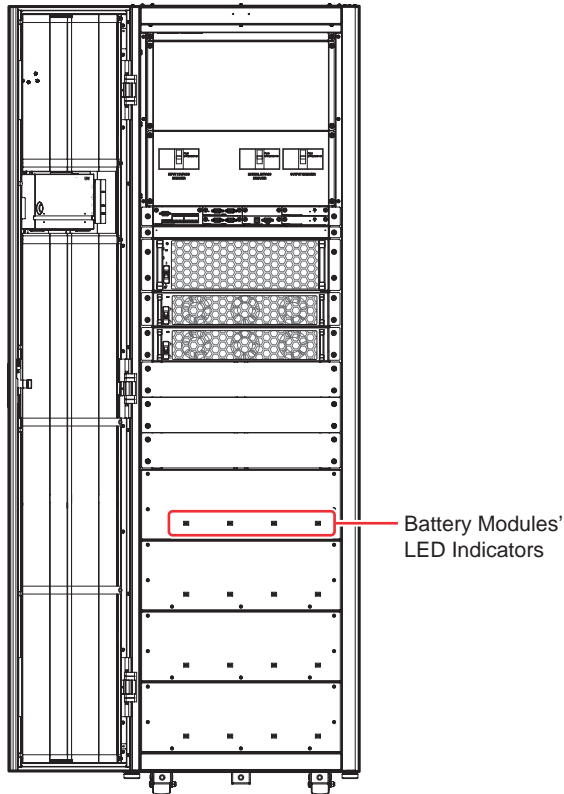

(Figure 5-55: Battery Modules' LED Indicators)

The battery module's LED indicator shows its operation status. Please refer to the following table:

LED Indicator	Description
OFF	The battery module is normal.
ON (red)	The battery module's fuses are broken.  NOTE: There are two fuses inside the battery module.

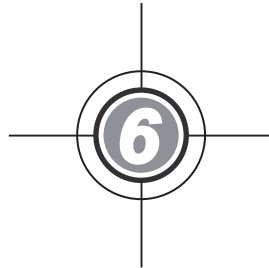

UPS Operation

- 6.1 Single Unit and Parallel Units Pre Start-up & Pre Turn-off Warnings
- 6.2 Start-up Procedures
- 6.3 Turn-off Procedures

6.1 Single Unit and Parallel Units Pre Start-up & Pre Turn-off Warnings



NOTE:

1. All unit No., UPS status, date, time, warning No., event No., load (%), battery remaining time, user login, administrator login, etc. shown in the LCD diagrams presented in **6. Operation** are for reference only. Actual readings depend on the operation of the UPS.
2. In this user manual, the meaning of Q1, Q2 and Q3 represents the following.

Code	Meaning
Q1	Input/ Bypass Breaker
Q2	Manual Bypass Breaker
Q3	Output Breaker

3. Before operation, ensure that installation and wiring have been completely done according to **5. Installation and Wiring**, and relevant instructions have been followed.
4. Before operation, please refer to **2.8 Tri-color LED Indicator & Buzzer** and **7. LCD Display & Settings**.

Single Unit

• Pre Start-up Warnings for Single Unit

1. Make sure that all of switches and breakers, including every external battery cabinet's breaker, are turned to the **OFF** position.
2. Make sure the voltage difference between the Neutral (N) and Ground (⊕) is < 3V.
3. Check if the wiring is correct. Make sure the AC power's voltage, frequency, phase and battery type meet the UPS's requirements.
4. Check if all power modules are properly installed and every power module's switch is in the upper position (). Please refer to **5.8 Power Module (Optional)** for more information.
5. If you install the battery modules (optional) in the UPS, ensure that they are properly connected and installed. Please refer to **5.9 Battery Module (Optional)** for more information.

• Pre Turn-off Warnings for Single Unit

If you perform turn-off procedures for single unit, all power will be completely cut off. Please make sure the critical loads connected to the UPS have already been safely shut down before you perform the turn-off procedures.

Parallel Units

- **Pre Start-up Warnings for Parallel Units**

1. You can parallel UPS units. For UPS parallel information and application, please contact Delta service personnel.
2. For parallel units, ensure that each parallel cable (provided) is connected well.
3. Make sure that all of switches and breakers, including every external battery cabinet's breaker, are turned to the **OFF** position.
4. Make sure the voltage difference between the Neutral (N) and Ground (\oplus) is $< 3V$.
5. Check if the wiring is correct. Make sure the AC power's voltage, frequency, phase and battery type meet the UPS's requirements.
6. Check if all power modules are properly installed and every power module's switch is in the upper position (). Please refer to **5.8 Power Module (Optional)** for more information.
7. If you install the battery modules (optional) in the UPS, ensure that they are properly connected and installed. Please refer to **5.9 Battery Module (Optional)** for more information.
8. For parallel units, ensure that every operation procedure is simultaneously executed and performed to all of the parallel UPSs.
9. For parallel application, if you just want to operate a specific UPS but not all parallel ones, please contact service personnel.

- **Pre Turn-off Warnings for Parallel Units**

1. If you want to turn off one of the parallel UPSs, please check whether the remaining parallel UPS's total capacity exceeds the total critical loads. If the remaining parallel UPS's total capacity is less than the total critical loads, all parallel UPSs will shut down due to overload.
2. If you perform turn-off procedures for all parallel UPSs, all power will be completely cut off. Please make sure the critical loads connected to the parallel UPSs have already been safely shut down before you perform the turn-off procedures.

6.2 Start-up Procedures

6.2.1 Online Mode Start-up Procedures



WARNING:

1. For parallel units, please follow **6.2.3 Bypass Mode Start-up Procedures** to turn on each parallel UPS. After confirming that parallel operation can be normally run, follow the following procedures step by step.
2. For parallel units, ensure that every operation procedure mentioned below is simultaneously executed and performed to all of the parallel UPSs.
3. For parallel application, if you just want to operate a specific UPS but not all parallel ones, please contact service personnel.

① Ensure that the Manual Bypass Breaker (Q2) is in the **OFF** position.

② Switch **ON** every external battery cabinet's breaker.

③ Switch **ON** the Input/ Bypass Breaker (Q1) and Output Breaker (Q3).

④ After you switch **ON** the Input/ Bypass Breaker (Q1), each auxiliary power card's LED indicator will illuminate green and the following status will occur simultaneously.

1. The system and each power module will start initialization. After each power module finishes initialization, each power module's fans will start running, each power module will start establishing DC BUS voltage and each power module's LED indicator will illuminate green.
2. Each parallel communication card's LED indicator will illuminate red first and then each parallel communication card will start initialization. After initialization, the master parallel communication card's LED indicator will illuminate green and the backup communication card's LED indicator will illuminate yellow.

Please refer to **Figure 6-1** for the relevant LED indicator location.

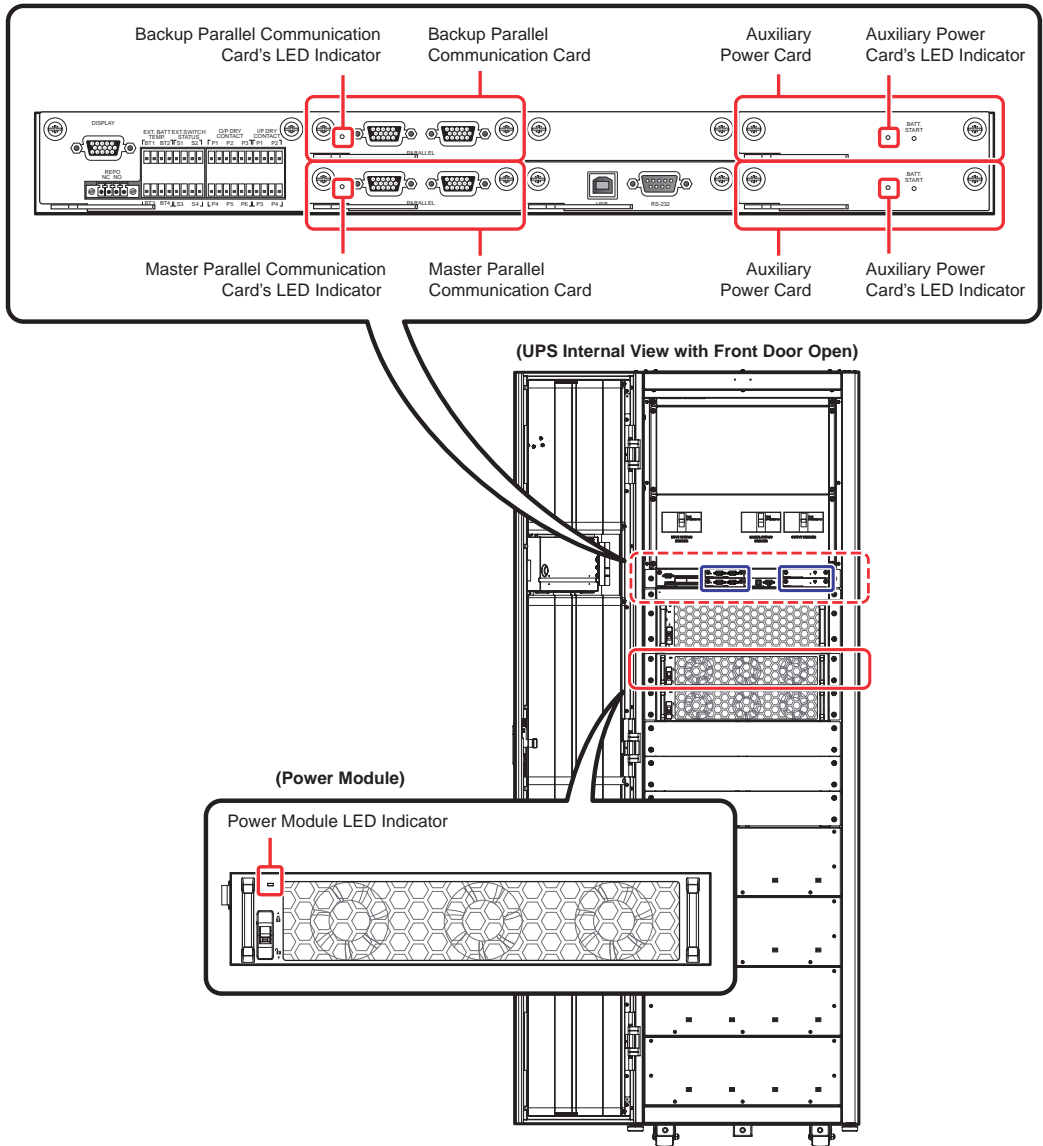

(Figure 6-1: LED Indicator Location for Each Power Module, Parallel Communication Card and Auxiliary Power Card)

- 5 The LCD initial screen (see **Figure 6-2**) will appear within 40 seconds after the Input/Bypass Breaker (Q1) is turned on.



(Figure 6-2: LCD Initial Screen)

- 6 After 20 seconds of LCD initialization, the LCD will enter the **Main Screen**. For the **Main Screen** information, please refer to **7.6 Main Screen**.

Now, each power module keeps running and its LED indicator remains green. After each power module finishes establishing DC BUS voltage, the charger will start to charge the batteries.

If the bypass AC source is within the normal range, the UPS will transfer to run in bypass mode, the LCD screen will show as **Figure 6-3** and the tri-color LED indicator will illuminate yellow. For the location of the tri-color LED indicator, please refer to **Figure 2-11**.

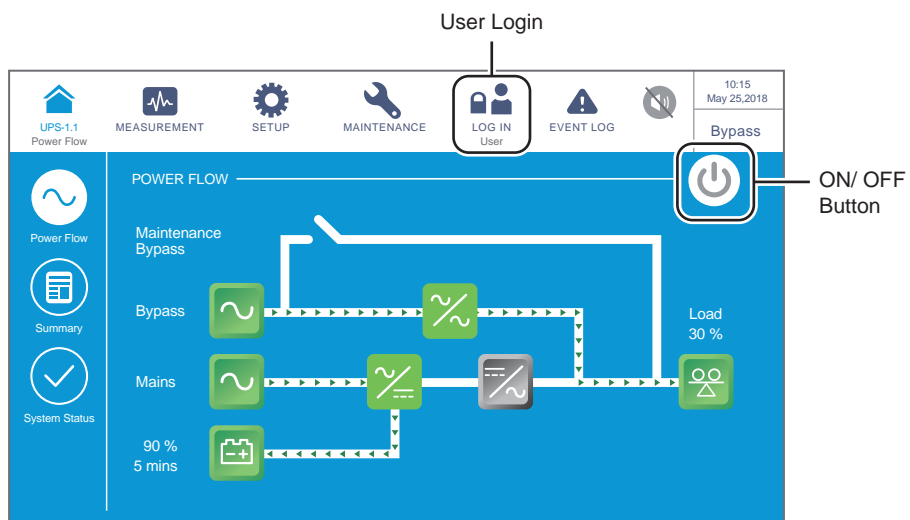

(Figure 6-3: Main Screen_ User Login & ON/ OFF Button Location)

- 7 Press the ON/ OFF button () once and the following screen will pop up to ask you if you want to power on the UPS's inverter. Please select 'YES'.

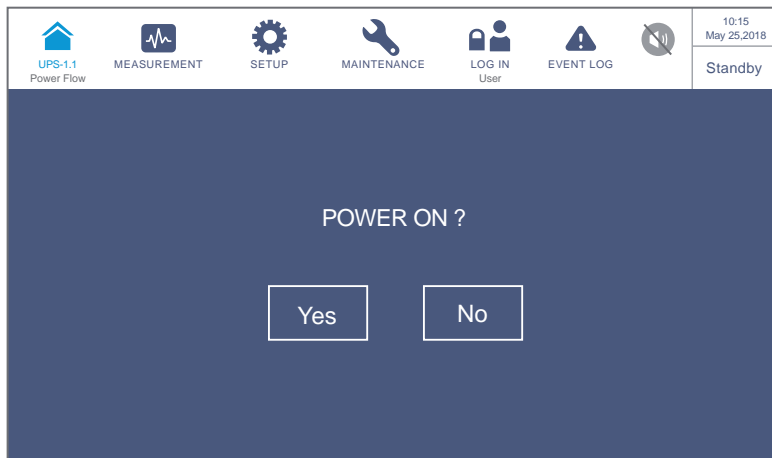

(Figure 6-4: Power on Reminder Screen)

- 8 After selection of 'YES' to start up the UPS's inverter, each power module will start up and perform self-inspection. At the same time, the system begins synchronization with the bypass AC source. After the self-inspection is completed, the UPS will automatically transfer to run in online mode, the tri-color LED indicator will illuminate green and the following screen will appear. For the tri-color LED indicator location, please refer to **Figure 2-11**.

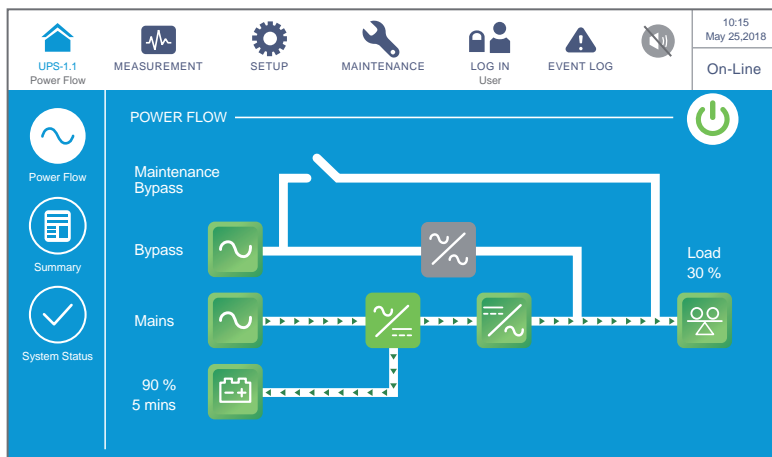

(Figure 6-5 : Online Mode Screen)

6.2.2 Battery Mode Start-up Procedures



WARNING:

1. For parallel units, please follow **6.2.3 Bypass Mode Start-up Procedures** to turn on each parallel UPS. After confirming that parallel operation can be normally run, follow the following procedures step by step.
2. For parallel units, ensure that every operation procedure mentioned below is simultaneously executed and performed to all of the parallel UPSs.
3. For parallel application, if you just want to operate a specific UPS but not all parallel ones, please contact service personnel.

- 1 Ensure that the Manual Bypass Breaker (Q2) is in the **OFF** position.
- 2 Switch **ON** every external battery cabinet's breaker.
- 3 Switch **ON** the Output Breaker (Q3).
- 4 Open the UPS's front door, press any of the **BATT START** buttons (see **Figure 7-2**) for one second and release it. After that, each auxiliary power card's LED indicator will illuminate green and the following status will occur simultaneously.
 1. The system and each power module will start initialization. After each power module finishes initialization, each power module's fans will start running.
 2. Each parallel communication card's LED indicator will illuminate red first and then each parallel communication card will start initialization. After initialization, the master parallel communication card's LED indicator will illuminate green and the backup communication card's LED indicator will illuminate yellow.

Please refer to **Figure 6-1** for the relevant LED indicator location.

- 5 The LCD initial screen (see **Figure 6-6**) will appear within 40 seconds after each auxiliary power card's LED indicator illuminates green.



(Figure 6-6: LCD Initial Screen)

- 6 After 20 seconds of LCD initialization, the LCD will enter the **Main Screen** shown in **Figure 6-7** and the tri-color LED indicator will illuminate yellow. For the location of the tri-color LED indicator, please refer to **Figure 2-11**.

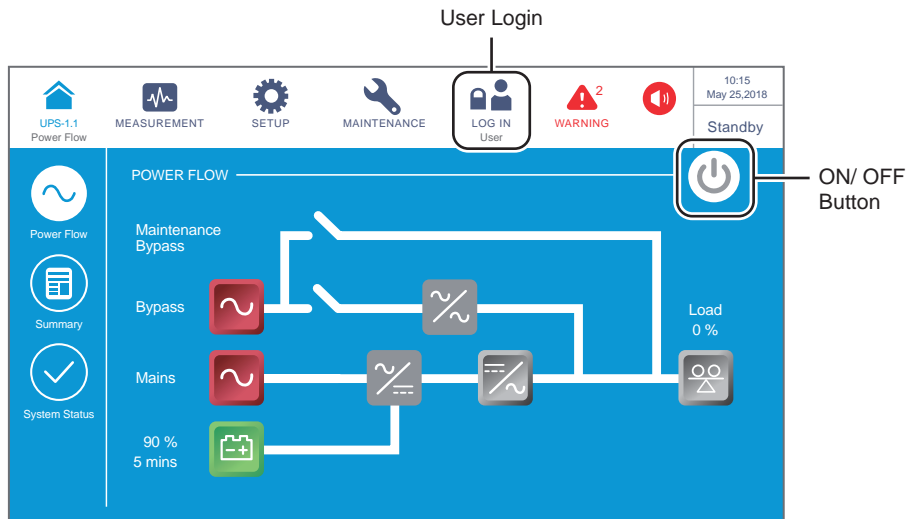

(Figure 6-7 : Main Screen_ User Login & ON/ OFF Button Location)

- 7 Press the ON/ OFF button (⏻) once and the following screen will pop up to ask you if you want to power on the UPS's inverter. Please select 'YES'.

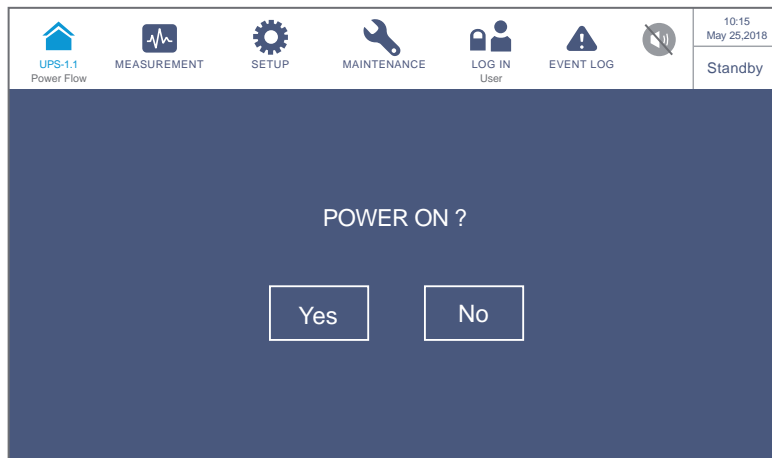

(Figure 6-8: Power On Reminder Screen)

- 8 After selection of 'YES' to start up the UPS's inverter, each power module will start up, each power module's LED indicator will illuminate green and each power module will perform self-inspection. After the self-inspection is completed, the UPS will automatically transfer to run in battery mode. At this moment, the tri-color LED indicator illuminates yellow and the following screen appears. For the tri-color LED indicator location, please refer to **Figure 2-11**.

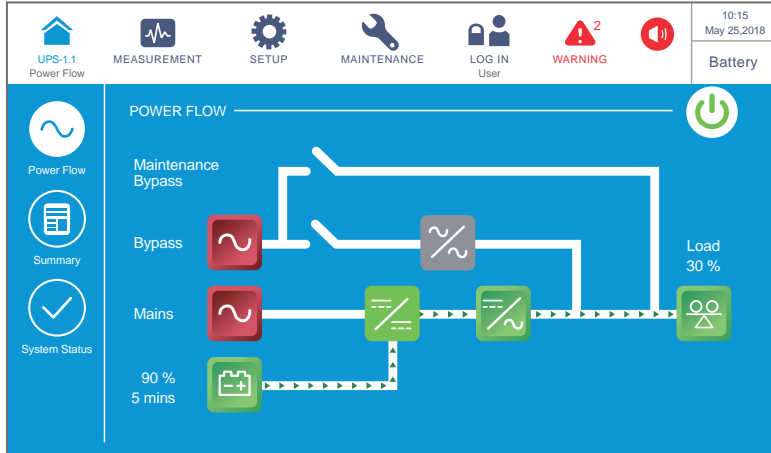

(Figure 6-9 : Battery Mode Screen)

6.2.3 Bypass Mode Start-up Procedures



WARNING:

1. For parallel units, ensure that every operation procedure mentioned below is simultaneously executed and performed to all of the parallel UPSs.
2. For parallel application, if you just want to operate a specific UPS but not all parallel ones, please contact service personnel.

- 1 Ensure that the Manual Bypass Breaker (Q2) is in the **OFF** position.
- 2 Switch **ON** every external battery cabinet's breaker.
- 3 Switch **ON** the Input/ Bypass Breaker (Q1).
- 4 After you switch **ON** the Input/ Bypass Breaker (Q1), each auxiliary power card's LED indicator will illuminate green and the following status will occur simultaneously.
 1. The system and each power module will start initialization. After each power module finishes initialization, each power module's fans will start running, each power module will start establishing DC BUS voltage and each power module's LED indicator will illuminate green.
 2. Each parallel communication card's LED indicator will illuminate red first and then each parallel communication card will start initialization. After initialization, the master parallel communication card's LED indicator will illuminate green and the backup communication card's LED indicator will illuminate yellow.

Please refer to **Figure 6-1** for the relevant LED indicator location.

- 5 The LCD initial screen (see **Figure 6-10**) will appear within 40 seconds after the Input Bypass Breaker (Q1) is turned on.



(Figure 6-10: LCD Initial Screen)

- 6 After 20 seconds of LCD initialization, the LCD will enter the **Main Screen**. For the **Main Screen** information, please refer to **7.6 Main Screen**.

Now, each power module keeps running and its LED indicator remains green. After each power module finishes establishing DC BUS voltage, the charger will start to charge the batteries.

If the bypass AC source is within the normal range, the UPS will transfer to run in bypass mode, the LCD screen will show as **Figure 6-11** and the tri-color LED indicator will illuminate yellow. For the location of the tri-color LED indicator, please refer to **Figure 2-11**.

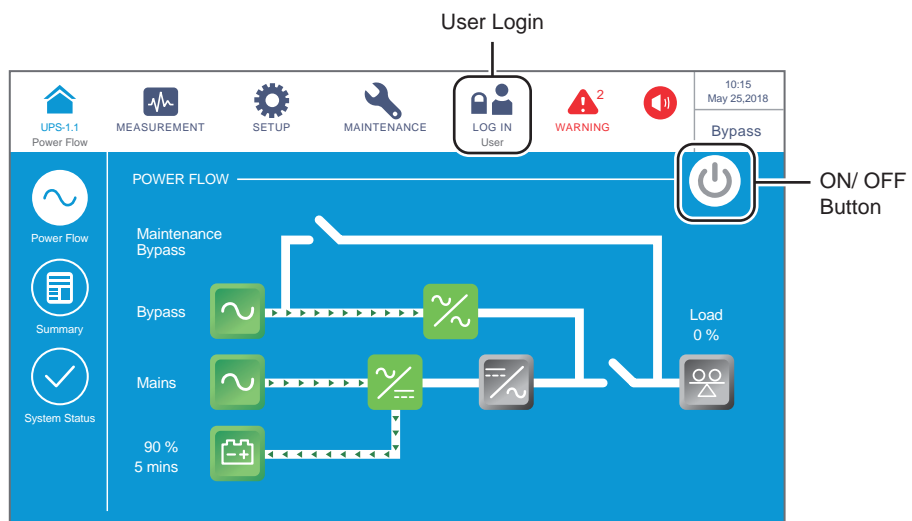

(Figure 6-11 : Main Screen_ User Login & ON/ OFF Button Location)

- 7 For parallel application, please check each parallel UPS's parallel settings. Please note that each parallel UPS's parallel ID No. must be different, and parallel group No., input, output and battery settings must be the same.
- 8 For parallel application, press the icon () located in the upper left corner of the screen and check if the total number of the parallel UPSs is correct. The UPS with the smallest parallel ID No. is defined as the master unit. Please refer to **Figure 6-12**.

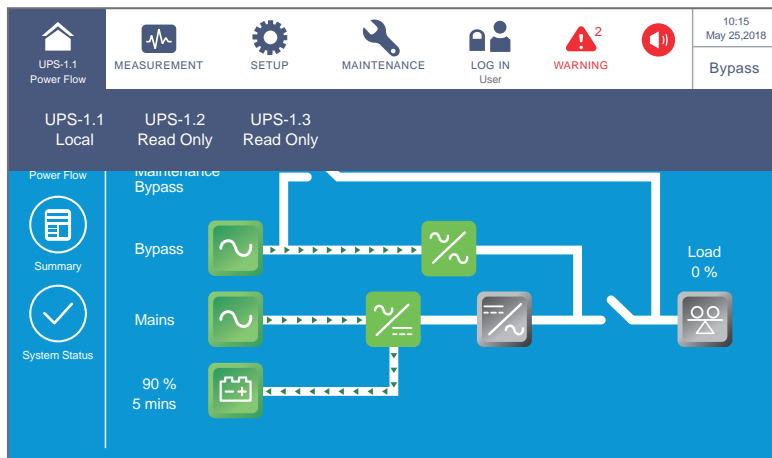

(Figure 6-12: Parallel ID No. Inquiry Screen)

- 9 For single unit, turn on the Output Breaker (Q3).

For parallel units, ensure that the output voltage difference between each parallel UPS is below 3V. If larger than 3V, it means abnormal and please contact service personnel immediately. If below 3V, turn on each parallel UPS's Output Breaker (Q3).

Now, the tri-color LED indicator illuminates yellow and the LCD shows the following screen (see **Figure 6-13**). For the location of the tri-color LED indicator, please refer to **Figure 2-11**.

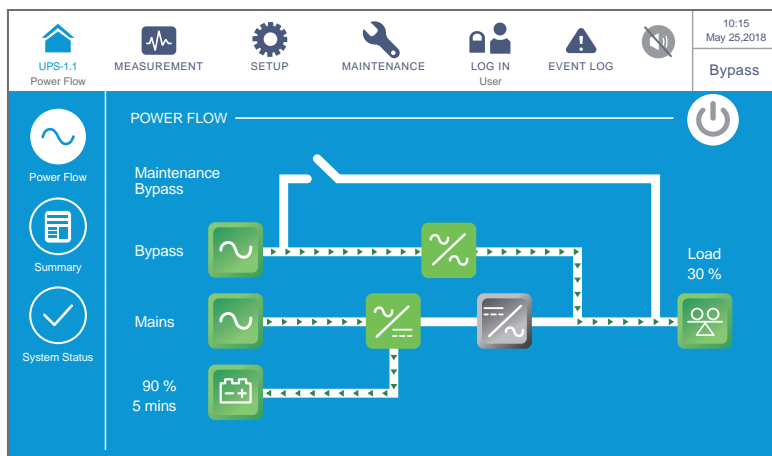

(Figure 6-13: Bypass Mode Screen)

6.2.4 Manual Bypass Mode Start-up Procedures



WARNING:

1. For parallel units, ensure that every operation procedure mentioned below is simultaneously executed and performed to all of the parallel UPSs.
2. For parallel application, if you just want to operate a specific UPS but not all parallel ones, please contact service personnel.
3. Please note that you can turn on the Manual Bypass Breaker (Q2) only when the UPS needs maintenance. In manual bypass mode, the connected critical loads will be supplied by the manual bypass and the output won't be protected. Please ensure that the bypass AC source is normal.
4. In manual bypass mode, the connected critical loads will be supplied by the manual bypass; thus, maintenance personnel can perform maintenance without interrupting the power supplying to the critical loads.
5. Ensure that all of the breakers and switches (except the Manual Bypass Breaker (Q2)) are in the **OFF** position, and use a voltmeter to check there is no high voltage inside the UPS (except the wiring terminals and the Manual Bypass Breaker (Q2)). Only after confirmation can service personnel perform UPS maintenance.
6. Please note that the wiring terminals and the Manual Bypass Breaker (Q2) have high voltage. Do not touch the wiring terminals and the Manual Bypass Breaker (Q2) during UPS maintenance process to avoid electric shock.

• From Online Mode to Manual Bypass Mode

- 1 In online mode, the LCD's main screen shows as follows and the tri-color LED indicator illuminates green. For the tri-color LED indicator location, please refer to **Figure 2-11**.

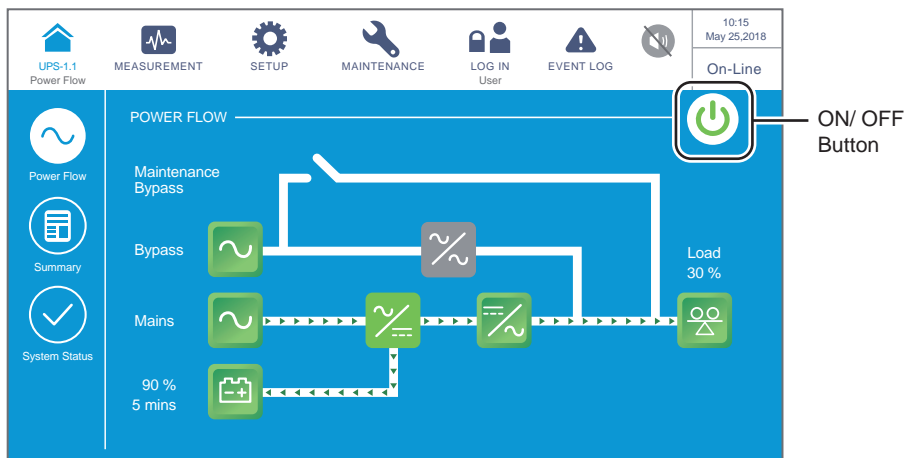

(Figure 6-14: Online Mode Screen_ User Login & ON/ OFF Button Location)

- 2) Press the ON/ OFF button () once and the following screen will pop up to ask you if you want to power off the inverter.

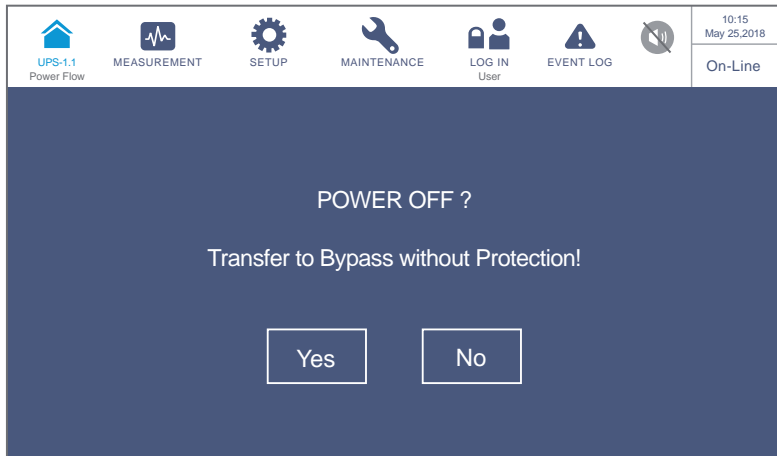

(Figure 6-15: Power Off Reminder Screen)

- 3) Check if the bypass voltage and STS module are normal or not. If normal, please select 'YES'. After that, the UPS will shut down the inverter and transfer to run in bypass mode.
- 4) Ensure that the UPS runs in bypass mode. After confirmation, turn on the Manual Bypass Breaker (Q2).
- 5) Turn off the Input/ Bypass Breaker (Q1) and the Output Breaker (Q3). After that, the screen shows as follows.

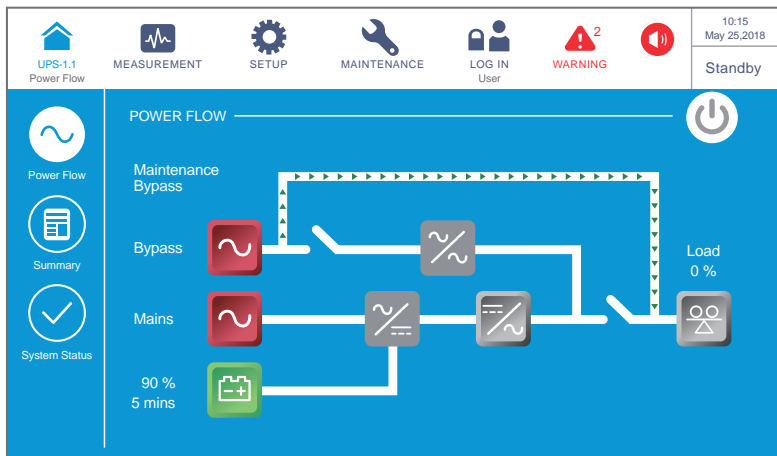

(Figure 6-16: Manual Bypass Mode Screen)

- 6) When the UPS performs DC BUS discharging, each power module's LED indicator flashes green. After discharging, each power module's LED indicator will be off.
- 7) About three minutes later, the UPS will shut down, and the LCD and the tri-color LED will be off.

- 8 Switch **OFF** every external battery cabinet's breaker.

• **From Manual Bypass Mode to Online Mode**



WARNING:

1. For parallel units, ensure that every operation procedure mentioned below is simultaneously executed and performed to all of the parallel UPSs.
2. For parallel application, if you just want to operate a specific UPS but not all parallel ones, please contact service personnel.

- 1 Switch **ON** every external battery cabinet's breaker.
- 2 Switch **ON** the Input/ Bypass Breaker (Q1) and the Output Breaker (Q3). After you switch **ON** the Input/ Bypass Breaker (Q1), each auxiliary power card's LED indicator will illuminate green and the following status will occur simultaneously.
1. The system and each power module will start initialization. After each power module finishes initialization, each power module's fans will start running, each power module will start establishing DC BUS voltage and each power module's LED indicator will illuminate green.
 2. Each parallel communication card's LED indicator will illuminate red first and then each parallel communication card will start initialization. After initialization, the master parallel communication card's LED indicator will illuminate green and the backup communication card's LED indicator will illuminate yellow.
- Please refer to **Figure 6-1** for the relevant LED indicator location.
- 3 The LCD initial screen (see **Figure 6-17**) will appear within 40 seconds after the Input/ Bypass Breaker (Q1) is turned on.



(Figure 6-17: LCD Initial Screen)

- 4 After 20 seconds of LCD initialization, the LCD will enter the **Main Screen**. For the **Main Screen** information, please refer to **7.6 Main Screen**.

Now, each power module keeps running and its LED indicator remains green. After each power module finishes establishing DC BUS voltage, the charger will start to charge the batteries.

If the bypass AC source is within the normal range, the UPS will transfer to run in bypass mode, the LCD screen will show as **Figure 6-18** and the tri-color LED indicator will illuminate yellow. For the location of the tri-color LED indicator, please refer to **Figure 2-11**.

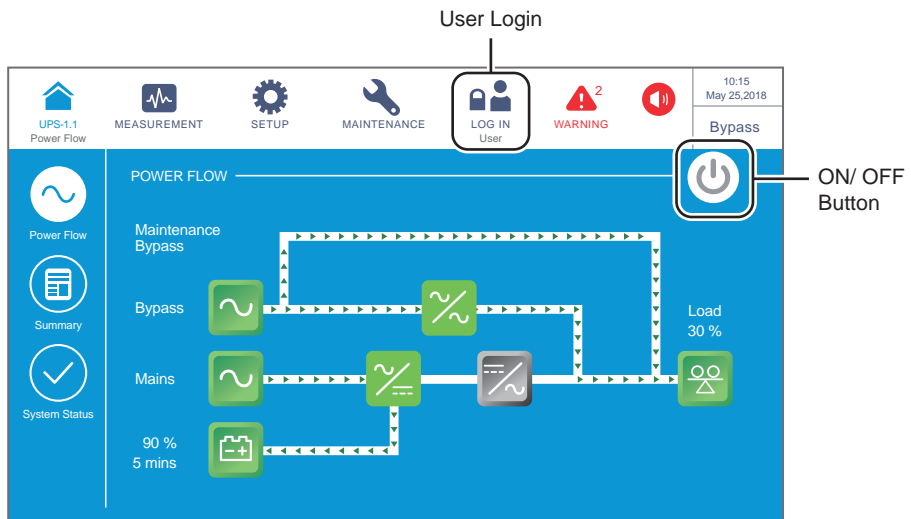

(Figure 6-18 : Manual Bypass Mode Screen_ User Login & ON/ OFF Button Location)

- 5) Switch **OFF** the Manual Bypass Breaker (Q2).
- 6) Press the ON/ OFF button (⏻) once and the following screen will pop up to ask you if you want to power on the inverter. Please select '**YES**'.



(Figure 6-19: Power On Reminder Screen)

- 7 After selection of 'YES' to start up the inverter, each power module will start up and perform self-inspection. At the same time, the system begins synchronization with the bypass AC source. After the self-inspection is completed, the UPS will automatically transfer to run in online mode, the tri-color LED indicator will illuminate green and the following screen will appear. For the tri-color LED indicator location, please refer to **Figure 2-11**.

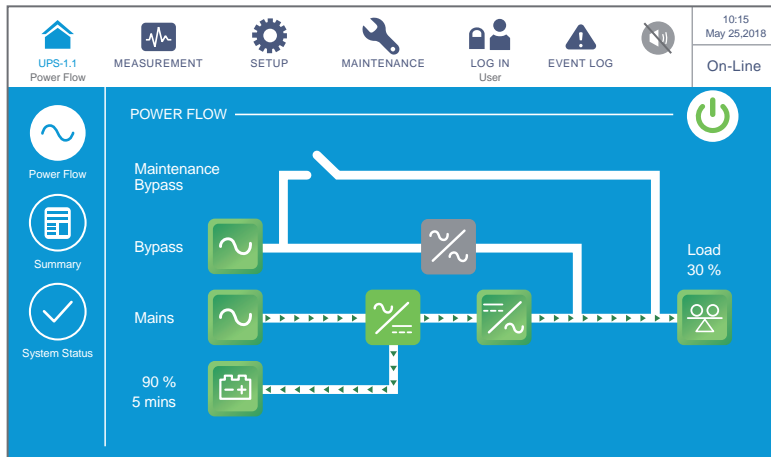

(Figure 6-20: Online Mode Screen)

6.2.5 ECO Mode Start-up Procedures



WARNING:

1. For parallel units, please follow **6.2.3 Bypass Mode Start-up Procedures** to turn on each parallel UPS. After confirming that parallel operation can be normally run, follow the following procedures step by step.
 2. For parallel units, ensure that every operation procedure mentioned below is simultaneously executed and performed to all of the parallel UPSs.
 3. For parallel application, if you just want to operate a specific UPS but not all parallel ones, please contact service personnel.
- 1 Ensure that the Manual Bypass Breaker (Q2) is in the **OFF** position.
 - 2 Switch **ON** every external battery cabinet's breaker.
 - 3 Switch **ON** the Input/ Bypass Breaker (Q1) and Output Breaker (Q3).
 - 4 After you switch **ON** the Input/ Bypass Breaker (Q1), each auxiliary power card's LED indicator will illuminate green and the following status will occur simultaneously.

1. The system and each power module will start initialization. After each power module finishes initialization, each power module's fans will start running, each power module will start establishing DC BUS voltage and each power module's LED indicator will illuminate green.
2. Each parallel communication card's LED indicator will illuminate red first and then each parallel communication card will start initialization. After initialization, the master parallel communication card's LED indicator will illuminate green and the backup communication card's LED indicator will illuminate yellow.

Please refer to **Figure 6-1** for the relevant LED indicator location.

- 5 The LCD initial screen (see **Figure 6-21**) will appear within 40 seconds after the Input/Bypass Breaker (Q1) is turned on.



(Figure 6-21: LCD Initial Screen)

- 6 After 20 seconds of LCD initialization, the LCD will enter the **Main Screen**. For the **Main Screen** information, please refer to **7.6 Main Screen**.

Now, each power module keeps running and its LED indicator remains green. After each power module finishes establishing DC BUS voltage, the charger will start to charge the batteries.

If the bypass AC source is within the normal range, the UPS will transfer to run in bypass mode, the LCD screen will show as **Figure 6-22** and the tri-color LED indicator will illuminate yellow. For the location of the tri-color LED indicator, please refer to **Figure 2-11**.

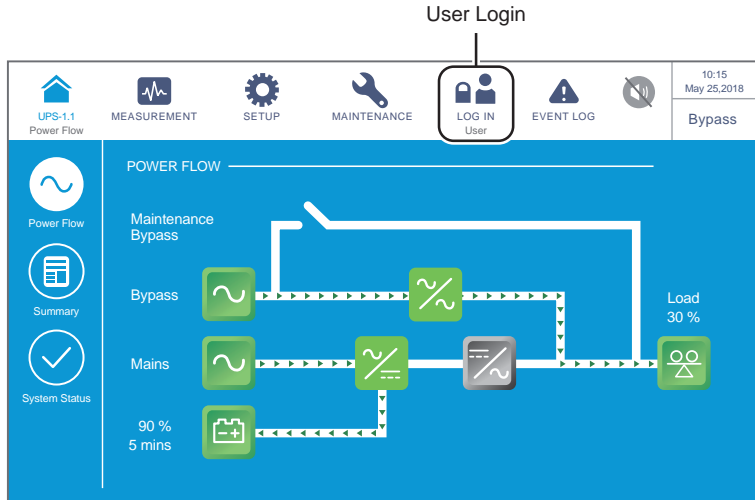

(Figure 6-22: Main Screen_ User Login)

- 7) Please log in as an **Administrator**. For the **Administrator** password, please contact service personnel. After login, ensure that you are in the **Administrator** login status (see **Figure 6-23**).

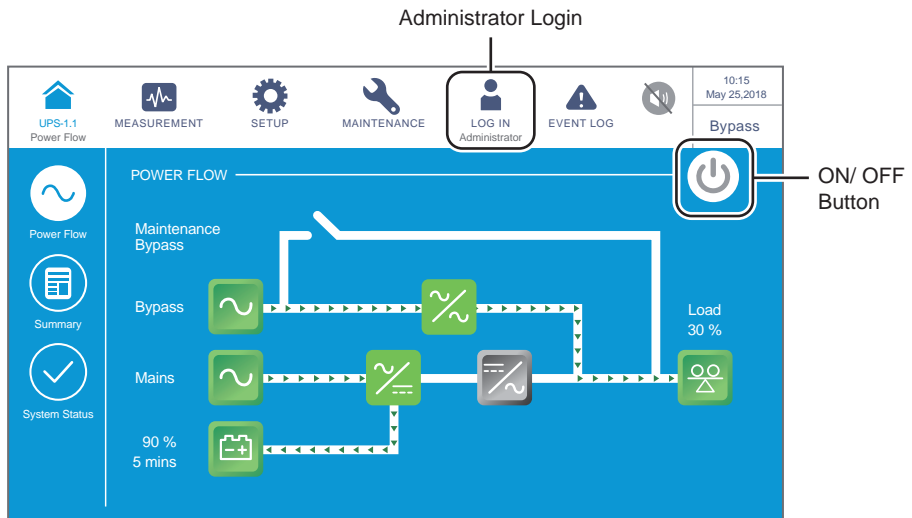

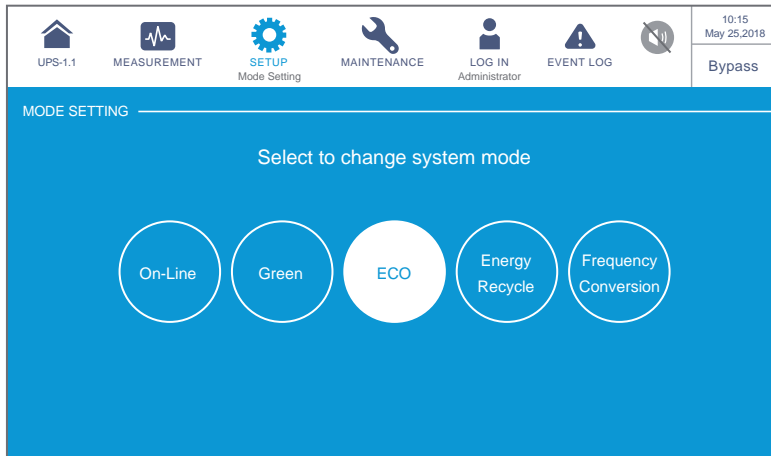

(Figure 6-23 : Main Screen_ Administrator Login & ON/ OFF Button Location)

- 8 Click **SETUP** → **Mode Setting** → **ECO**.



(Figure 6-24: Select ECO Mode)

- 9 After manually selecting **ECO** mode via the LCD, press the icon () located in the upper left corner of the screen to go back to the **Main Screen**.
- 10 Press the ON/ OFF button () once and the following screen will pop up to ask you if you want to power on the inverter. Please select '**YES**'.

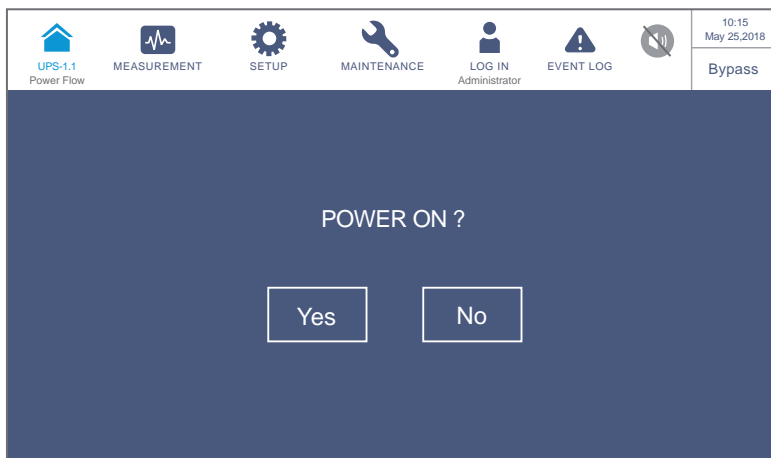

(Figure 6-25: Power On Reminder Screen)

- 11 After selection of '**YES**' to start up the inverter, each power module will start up and perform self-inspection. At the same time, the system begins synchronization with the bypass AC source. After the self-inspection is completed, the UPS will automatically transfer to run in online mode. After the system confirms that the bypass voltage is normal, the UPS will automatically switch to run in ECO mode to let the bypass AC source supply power (see **Figure 6-26**). Now, the tri-color LED indicator illuminates green and the following screen appears. For the tri-color LED indicator location, please refer to **Figure 2-11**.

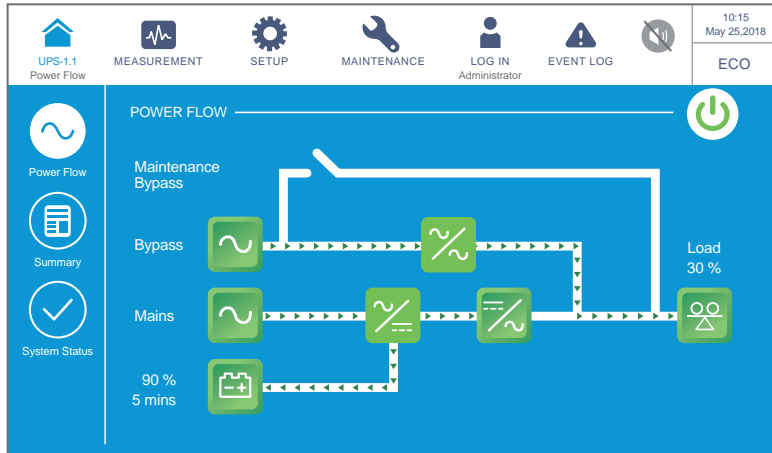

(Figure 6-26: ECO Mode Screen)

6.2.6 Frequency Conversion Mode Start-up Procedures



WARNING:

1. For parallel units, please follow **6.2.3 Bypass Mode Start-up Procedures** to turn on each parallel UPS. After confirming that parallel operation can be normally run, follow the following procedures step by step.
2. For parallel units, ensure that every operation procedure mentioned below is simultaneously executed and performed to all of the parallel UPSs.
3. For parallel application, if you just want to operate a specific UPS but not all parallel ones, please contact service personnel.

1. Ensure that the Manual Bypass Breaker (Q2) is in the **OFF** position.
2. Switch **ON** every external battery cabinet's breaker.
3. Switch **ON** the Input/ Bypass Breaker (Q1) and Output Breaker (Q3).
4. After you switch **ON** the Input/ Bypass Breaker (Q1), each auxiliary power card's LED indicator will illuminate green and the following status will occur simultaneously.
 1. The system and each power module will start initialization. After each power module finishes initialization, each power module's fans will start running, each power module will start establishing DC BUS voltage and each power module's LED indicator will illuminate green.
 2. Each parallel communication card's LED indicator will illuminate red first and then each parallel communication card will start initialization. After initialization, the master parallel communication card's LED indicator will illuminate green and the backup communication card's LED indicator will illuminate yellow.

Please refer to **Figure 6-1** for the relevant LED indicator location.

- 5 The LCD initial screen (see **Figure 6-27**) will appear within 40 seconds after the Input/Bypass Breaker (Q1) is turned on.



(Figure 6-27: LCD Initial Screen)

- 6 After 20 seconds of LCD initialization, the LCD will enter the **Main Screen**. For the **Main Screen** information, please refer to **7.6 Main Screen**.

Now, each power module keeps running and its LED indicator remains green. After each power module finishes establishing DC BUS voltage, the charger will start to charge the batteries.

If the bypass AC source is within the normal range, the UPS will transfer to run in bypass mode, the LCD screen will show as **Figure 6-33** and the tri-color LED indicator will illuminate yellow. For the location of the tri-color LED indicator, please refer to **Figure 2-11**.

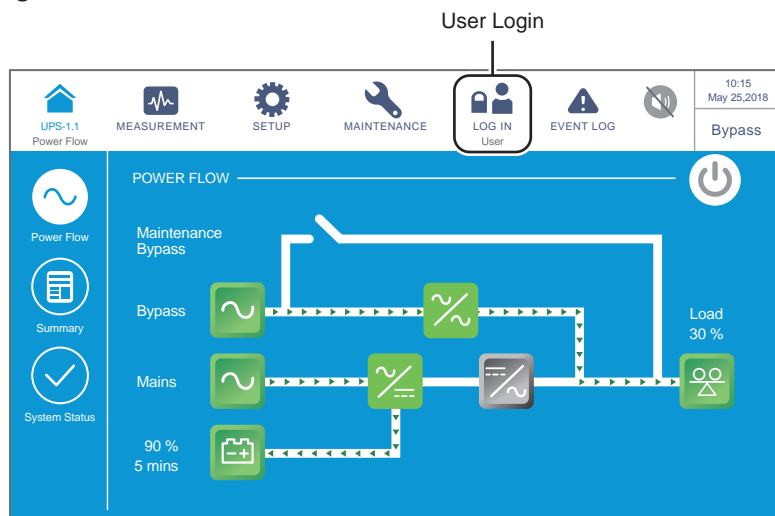

(Figure 6-28: Main Screen_ User Login)

- 7) Please log in as an **Administrator**. For the **Administrator** password, please contact service personnel. After login, ensure that you are in the **Administrator** login status (see **Figure 6-29**).

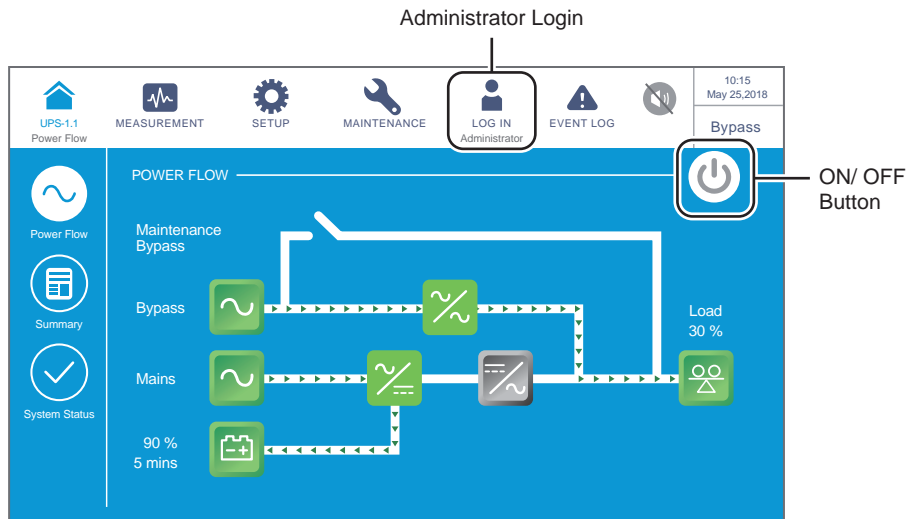

(Figure 6-29 : Main Screen_ Administrator Login & ON/ OFF Button Location)

- 8) Click **SETUP** → **Mode Setting** → **Frequency Conversion**.

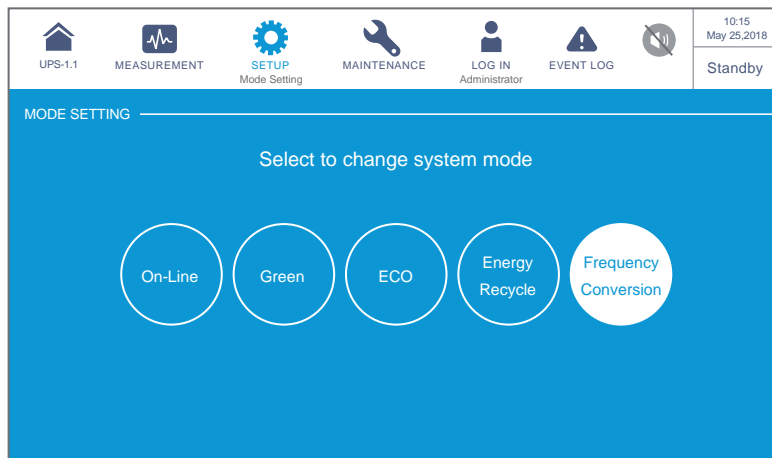

(Figure 6-30: Select Frequency Conversion Mode)

- 9) After manually selecting **Frequency Conversion** mode via the LCD, the UPS will run in standby mode and the output will be terminated.
- 10) Press the icon () located in the upper left corner of the screen to go back to the **Main Screen**.

- 11 Press the ON/ OFF button (🔌) once and the following screen will pop up to ask you if you want to power on the inverter. Please select 'YES'.

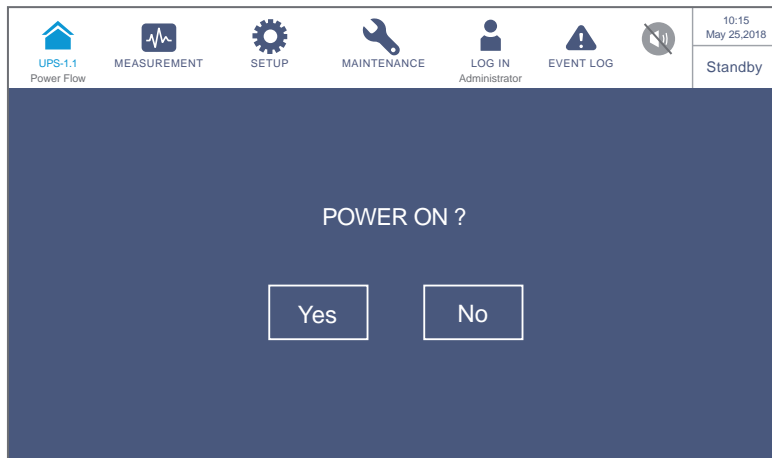

(Figure 6-31: Power On Reminder Screen)

- 12 After selection of 'YES' to start up the inverter, each power module will start up and perform self-inspection. After the self-inspection is completed, the UPS will automatically transfer to run in frequency conversion mode and the output frequency will be the same as setup value. Now, the tri-color LED indicator illuminates green and the following screen appears. For the tri-color LED indicator location, please refer to **Figure 2-11**.

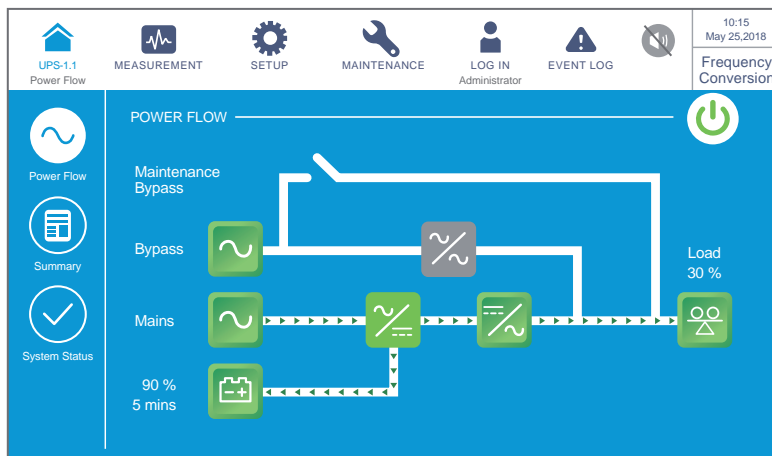

(Figure 6-32: Frequency Conversion Mode Screen)

6.2.7 Green Mode Start-up Procedures

- 1) Ensure that the Manual Bypass Breaker (Q2) is in the **OFF** position.
- 2) Switch **ON** every external battery cabinet's breaker.
- 3) Switch **ON** the Input/ Bypass Breaker (Q1) and Output Breaker (Q3).
- 4) After you switch **ON** the Input/ Bypass Breaker (Q1), each auxiliary power card's LED indicator will illuminate green and the following status will occur simultaneously.
 1. The system and each power module will start initialization. After each power module finishes initialization, each power module's fans will start running, each power module will start establishing DC BUS voltage and each power module's LED indicator will illuminate green.
 2. Each parallel communication card's LED indicator will illuminate red first and then each parallel communication card will start initialization. After initialization, the master parallel communication card's LED indicator will illuminate green and the backup communication card's LED indicator will illuminate yellow.

Please refer to **Figure 6-1** for the relevant LED indicator location.

- 5) The LCD initial screen (see **Figure 6-33**) will appear within 40 seconds after the Input/ Bypass Breaker (Q1) is turned on.



(Figure 6-33: LCD Initial Screen)

- 6) After 20 seconds of LCD initialization, the LCD will enter the **Main Screen**. For the **Main Screen** information, please refer to **7.6 Main Screen**.

Now, each power module keeps running and its LED indicator remains green. After each power module finishes establishing DC BUS voltage, the charger will start to charge the batteries.

If the bypass AC source is within the normal range, the UPS will transfer to run in bypass mode, the LCD screen will show as **Figure 6-34** and the tri-color LED indicator will illuminate yellow. For the location of the tri-color LED indicator, please refer to **Figure 2-11**.

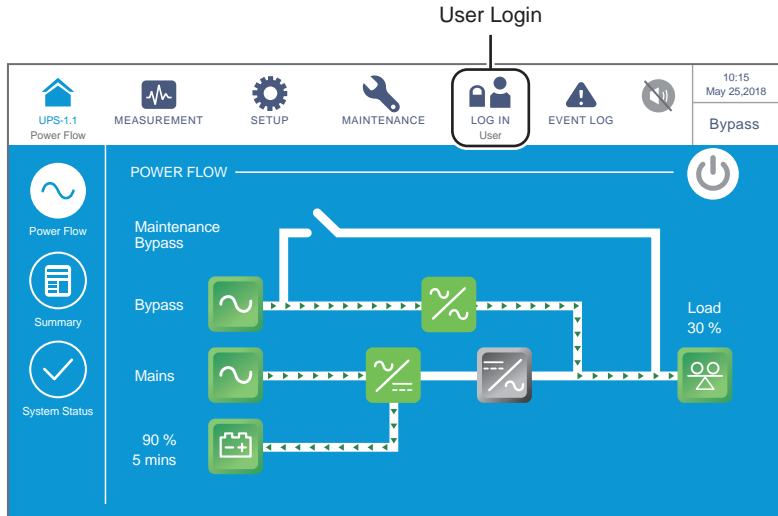

(Figure 6-34: Main Screen_ User Login)

- 7 Please log in as an **Administrator**. For the **Administrator** password, please contact service personnel. After login, ensure that you are in the **Administrator** login status. Please refer to **Figure 6-35**.

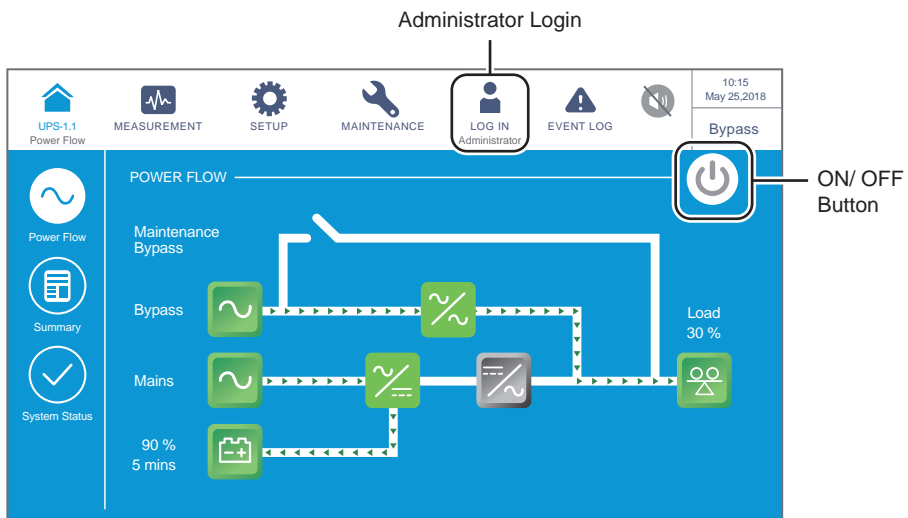

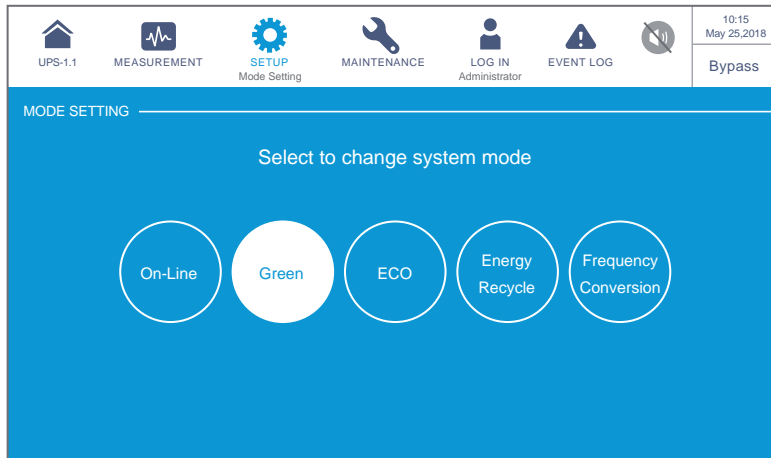

(Figure 6-35: Main Screen_ Administrator Login & ON/ OFF Button Location)

- 8 Click **SETUP** → **Mode Setting** → **Green**.



(Figure 6-36: Select Green Mode)

- 9 After manually selecting **Green** mode via the LCD, press the icon () located in the upper left corner of the screen to go back to the **Main Screen**.
- 10 Press the ON/ OFF button () once and the following screen will pop up to ask you if you want to power on the inverter. Please select '**YES**'.

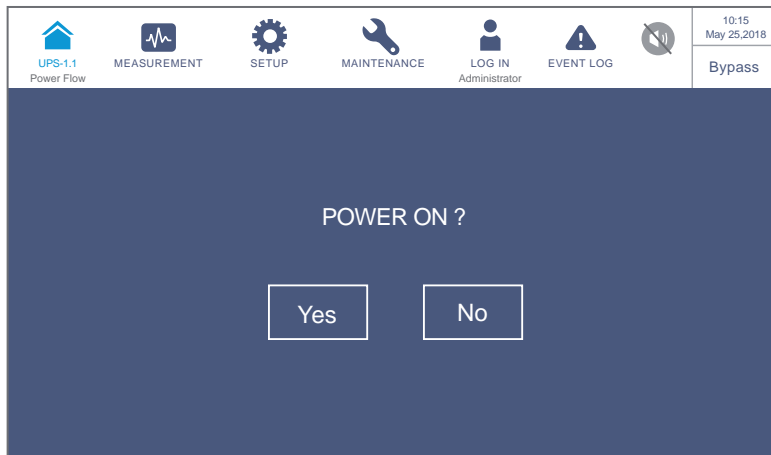

(Figure 6-37: Power On Reminder Screen)

- 11) After selection of 'YES' to start up the inverter, each power module will start up and perform self-inspection. At the same time, the system begins synchronization with the bypass AC source. After the self-inspection is completed, the UPS will automatically transfer to run in green mode and the system will automatically detect the output status (i.e. total load capacity %) to decide which specific power modules should be fully powered on or idle in order to achieve higher efficiency of the UPS. Now, the tri-color LED indicator illuminates green and the following screen appears. For the tri-color LED indicator location, please refer to **Figure 2-11**.

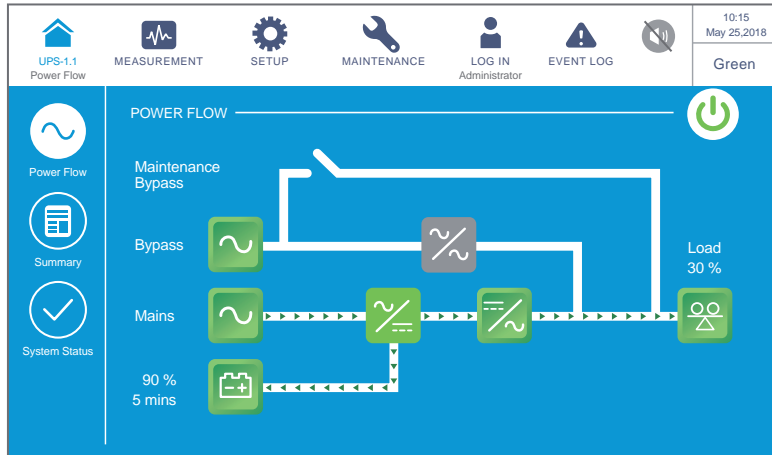

(Figure 6-38: Green Mode Screen)

6.2.8 Energy Recycle Mode Start-up Procedures



WARNING: Energy recycle mode is only applicable to single input and single unit application.

- 1) Ensure that the Manual Bypass Breaker (Q2) is in the **OFF** position.
- 2) Switch **ON** the Input/ Bypass Breaker (Q1).
- 3) After you switch **ON** the Input/ Bypass Breaker (Q1), each auxiliary power card's LED indicator will illuminate green and the following status will occur simultaneously.
 1. The system and each power module will start initialization. After each power module finishes initialization, each power module's fans will start running, each power module will start establishing DC BUS voltage and each power module's LED indicator will illuminate green.
 2. Each parallel communication card's LED indicator will illuminate red first and then each parallel communication card will start initialization. After initialization, the master parallel communication card's LED indicator will illuminate green and the backup communication card's LED indicator will illuminate yellow.

Please refer to **Figure 6-1** for the relevant LED indicator location.

- 4 The LCD initial screen (see **Figure 6-39**) will appear within 40 seconds after the Input/Bypass Breaker (Q1) is turned on.



(Figure 6-39: LCD Initial Screen)

- 5 After 20 seconds of LCD initialization, the LCD will enter the **Main Screen**. For the **Main Screen** information, please refer to **7.6 Main Screen**.

Now, each power module keeps running and its LED indicator remains green. After each power module finishes establishing DC BUS voltage, the charger will start to charge the batteries.

If the bypass AC source is within the normal range, the UPS will transfer to run in bypass mode, the LCD screen will show as **Figure 6-40** and the tri-color LED indicator will illuminate yellow. For the location of the tri-color LED indicator, please refer to **Figure 2-11**.

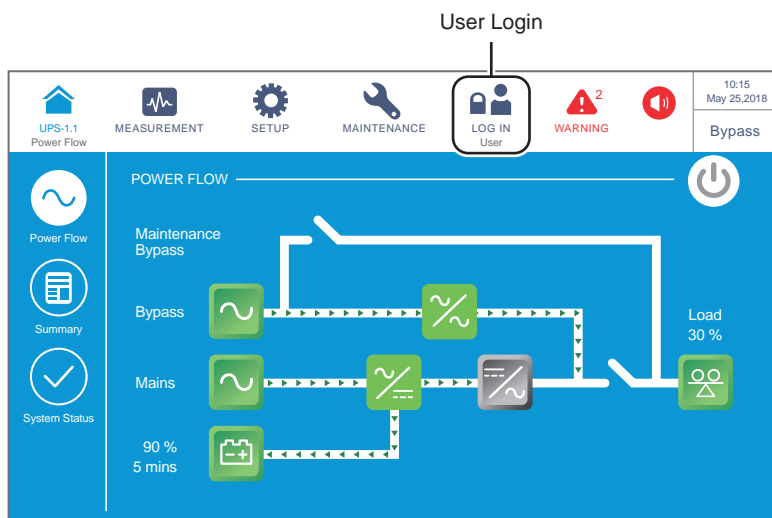

(Figure 6-40: Main Screen_ User Login)

- 6 Please log in as an **Administrator**. For the **Administrator** password, please contact service personnel. After login, ensure that you are in the **Administrator** login status (see **Figure 6-41**).

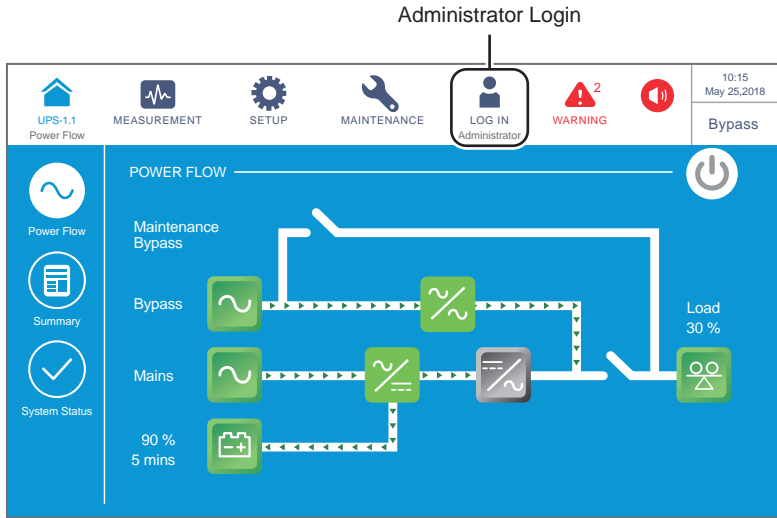

(Figure 6-41: Main Screen_ Administrator Login & ON/ OFF Button Location)

- 7 Click **SETUP** → **Mode Setting** → **Energy Recycle**.

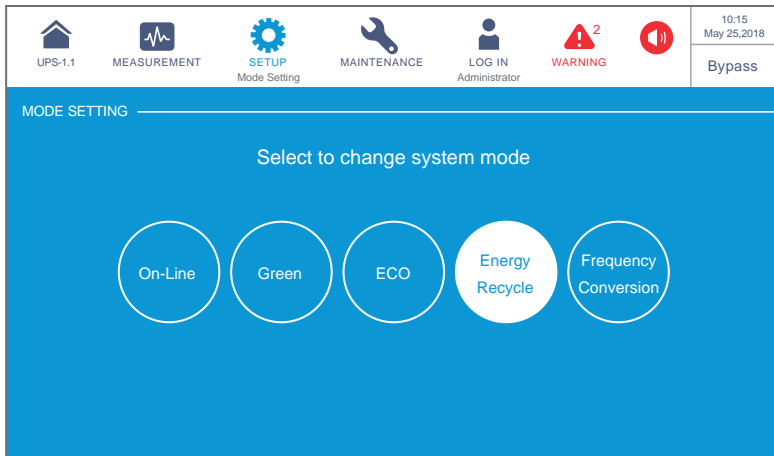

(Figure 6-42: Select Energy Recycle Mode)

- 8 After manually selecting **Energy Recycle** mode via the LCD, press the icon () located in the upper left corner of the screen to go back to the **Main Screen**.

- 9 Press the ON/ OFF button () once and the following screen will pop up to ask you if you want to power on the inverter. Please select 'YES'.

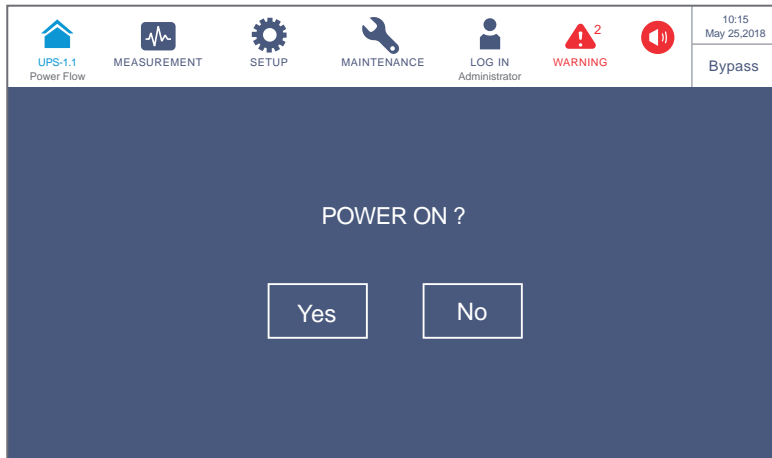

(Figure 6-43: Power On Reminder Screen)

- 10 After selection of 'YES' to start up the inverter, each power module will start up and perform self-inspection. At the same time, the system begins synchronization with the bypass AC source. After the self-inspection is completed, the UPS will automatically transfer to run in energy recycle mode and perform self-aging test. Now, the tri-color LED indicator illuminates yellow and the following screen appears. For the tri-color LED indicator location, please refer to **Figure 2-11**.

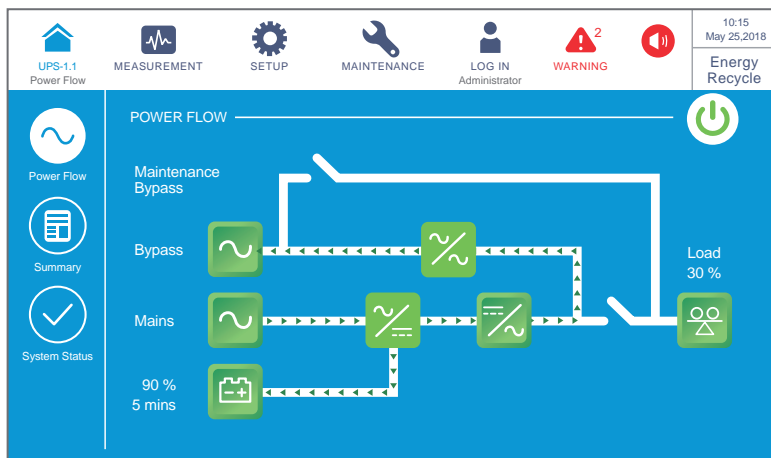

(Figure 6-44: Energy Recycle Mode Screen)

6.3 Turn-off Procedures

6.3.1 Online Mode Turn-off Procedures



WARNING:

1. For parallel units, ensure that every operation procedure mentioned below is simultaneously executed and performed to all of the parallel UPSs.
2. For parallel application, if you just want to operate a specific UPS but not all parallel ones, please contact service personnel.

- 1 In online mode, the LCD shows the following screen and the tri-color LED indicator illuminates green. For the tri-color LED indicator location, please refer to **Figure 2-11**.

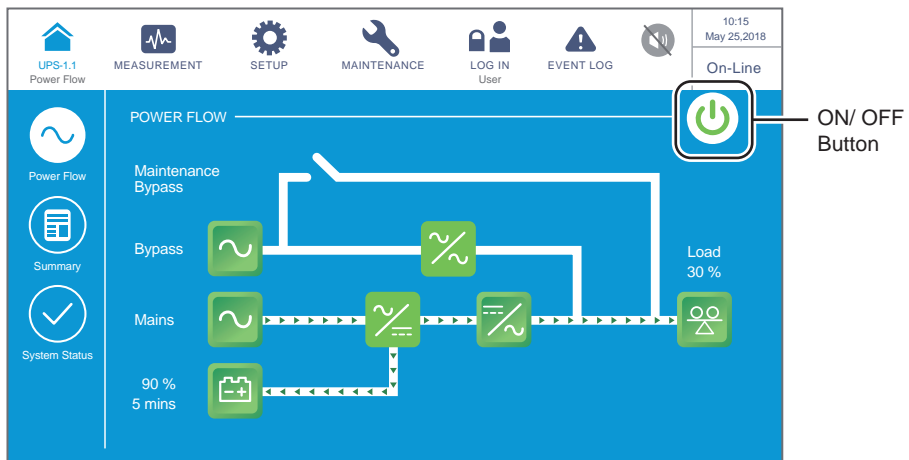

(Figure 6-45: Online Mode Screen_ User Login & ON/ OFF Button Location)

- 2 Press the ON/ OFF button () once and the following screen will pop up to ask you if you want to power off the inverter. Check if the bypass voltage and STS module are normal or not. If normal, please select 'YES'.

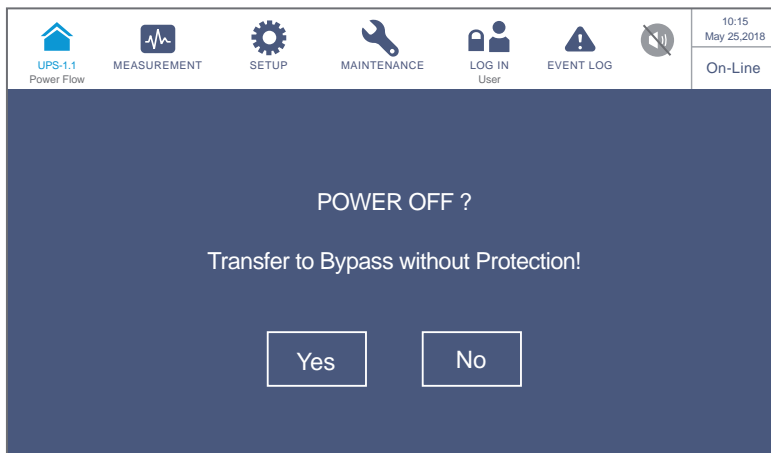

(Figure 6-46: Power Off Reminder Screen)

- 3 After selection of 'YES', the UPS will shut down the inverter, terminate each power module's output and let the bypass AC source supply power. If the bypass AC source is abnormal, there is a risk of output interruption and the connected critical loads won't be protected. At this moment, each power module keeps charging the batteries, the tri-color LED indicator illuminates yellow and the following screen appears. For the tri-color LED indicator location, please refer to **Figure 2-11**.

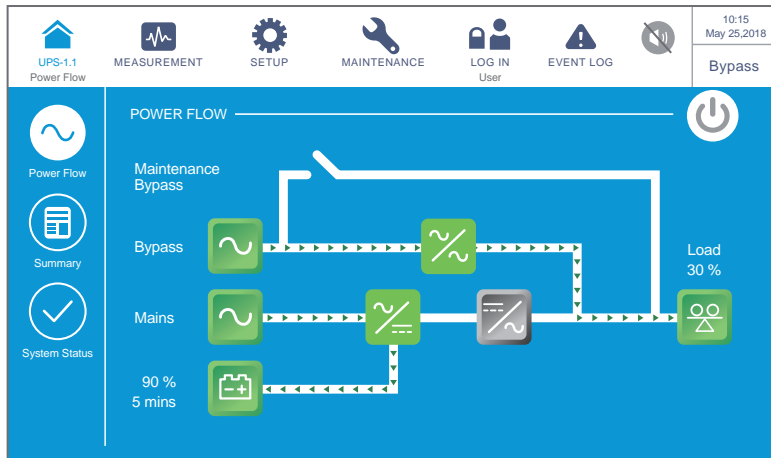

(Figure 6-47: Bypass Mode Screen)

- 4 Switch **OFF** the Input/ Bypass Breaker (Q1) and Output Breaker (Q3). After that, the UPS will run in standby mode.
- 5 Now, each power module performs DC BUS discharging and its LED indicator flashes green. After discharging, each power module's LED indicator will be off.
- 6 About 3 minutes later, the UPS will shut down and the LCD and the tri-color LED indicator will be off.
- 7 Switch **OFF** every external battery cabinet's breaker.

6.3.2 Battery Mode Turn-off Procedures



WARNING:

1. For parallel units, ensure that every operation procedure mentioned below is simultaneously executed and performed to all of the parallel UPSs.
2. For parallel application, if you just want to operate a specific UPS but not all parallel ones, please contact service personnel.

- 1 In battery mode, the LCD shows the following screen and the tri-color LED indicator illuminates yellow. For the tri-color LED indicator location, please refer to **Figure 2-11**.

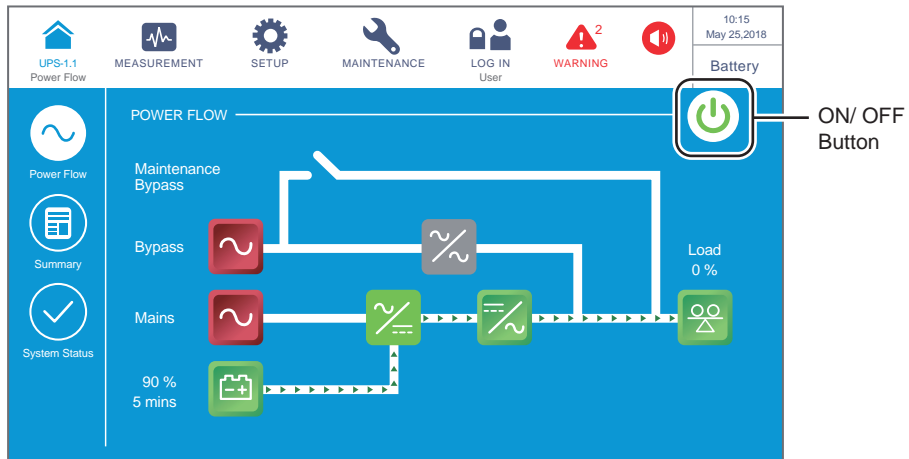

(Figure 6-48: Battery Mode Screen & ON/ OFF Button Location)

- 2 Press the ON/ OFF button () once and the following screen will pop up to ask you if you want to power off the inverter. Please select 'YES'.



WARNING:

Please note that, once you select 'YES', all power will be completely cut off. Please make sure the critical loads connected to the UPS have already been safely shut down before you perform the turn-off procedures.

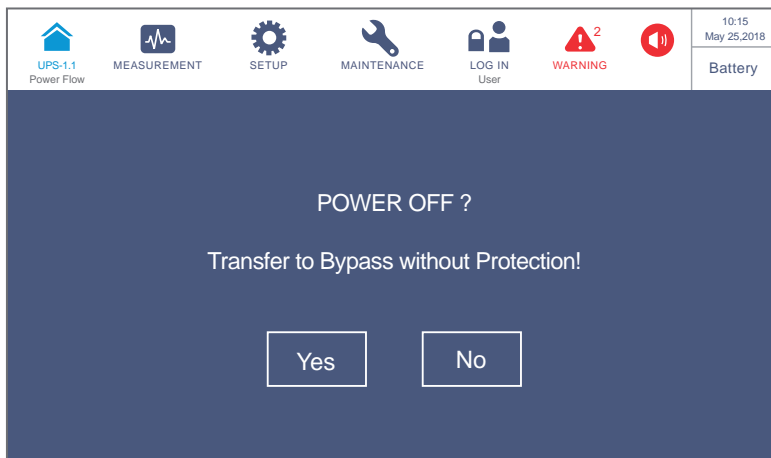

(Figure 6-49: Power Off Reminder Screen)

- 3 After selection of 'YES', the UPS will shut down the inverter, terminate each power module's output and transfer to run in standby mode. Meanwhile, the output will be terminated. At this moment, the tri-color LED indicator illuminates yellow and the following screen appears. For the tri-color LED indicator location, please refer to **Figure 2-11**.

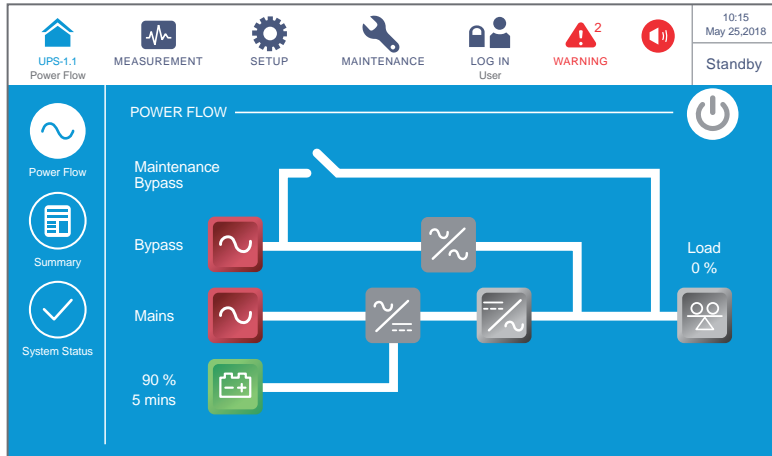

(Figure 6-50: Standby Mode Screen)

- 4 Switch **OFF** the Input/ Bypass Breaker (Q1) and Output Breaker (Q3).
- 5 Each power module performs DC BUS discharging and its LED indicator flashes green. After discharging, each power module's LED indicator will be off.
- 6 About 3 minutes later, the UPS will shut down and the LCD and the tri-color LED indicator will be off.
- 7 Switch **OFF** every external battery cabinet's breaker.

6.3.3 Bypass Mode Turn-off Procedures



WARNING:

1. For parallel units, ensure that every operation procedure mentioned below is simultaneously executed and performed to all of the parallel UPSs.
2. For parallel application, if you just want to operate a specific UPS but not all parallel ones, please contact service personnel.

- 1 In bypass mode, the LCD shows the following screen and the tri-color LED indicator illuminates yellow. For the tri-color LED indicator location, please refer to **Figure 2-11**.

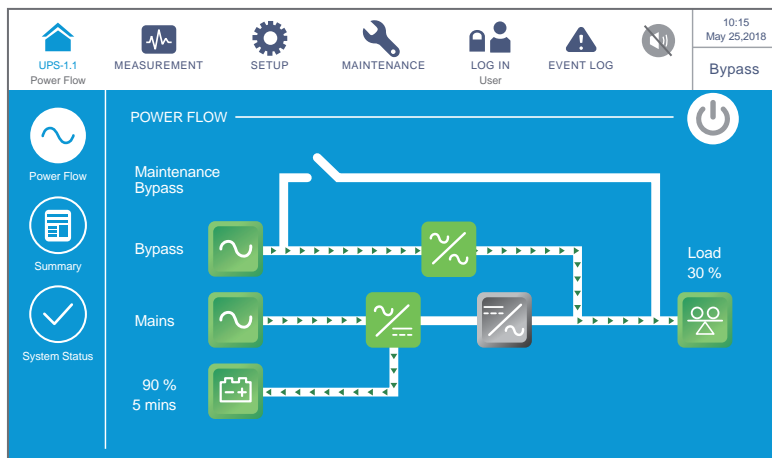

(Figure 6-51: Bypass Mode Screen)

- 2 Switch **OFF** the Input/ Bypass Breaker (Q1) and Output Breaker (Q3). After that, the UPS will run in standby mode.
- 3 Now, each power module performs DC BUS discharging and its LED indicator flashes green. After discharging, each power module's LED indicator will be off.
- 4 About 3 minutes later, the UPS will shut down and the LCD and the tri-color LED indicator will be off.
- 5 Switch **OFF** every external battery cabinet's breaker.

6.3.4 Manual Bypass Mode Turn-off Procedures



WARNING:

1. For parallel units, ensure that every operation procedure mentioned below is simultaneously executed and performed to all of the parallel UPSs.
2. For parallel application, if you just want to operate a specific UPS but not all parallel ones, please contact service personnel.

In manual bypass mode, the LCD and the tri-color LED indicator are both **OFF**. For the tri-color LED indicator location, please refer to **Figure 2-11**. To completely shut down the UPS, switch **OFF** the Manual Bypass Breaker (Q2).



NOTE:

1. Ensure that the LCD, all LED indicators and fans are **OFF**.
2. Check that all breakers, switches and power are **OFF**.

6.3.5 ECO Mode Turn-off Procedures



WARNING:

1. For parallel units, ensure that every operation procedure mentioned below is simultaneously executed and performed to all of the parallel UPSs.
2. For parallel application, if you just want to operate a specific UPS but not all parallel ones, please contact service personnel.

- 1 In ECO mode, the LCD shows the following screen and the tri-color LED indicator illuminates green. For the tri-color LED indicator location, please refer to **Figure 2-11**.

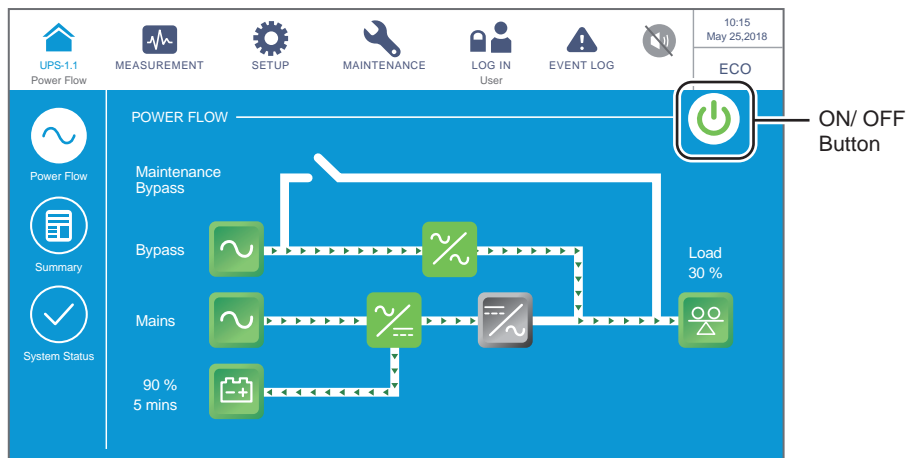

(Figure 6-52: ECO Mode Screen & ON/ OFF Button Location)

- 2 Press the ON/ OFF button () once and the following screen will pop up to ask you if you want to power off the inverter. Check if the bypass voltage and STS module are normal or not. If normal, please select 'YES'.

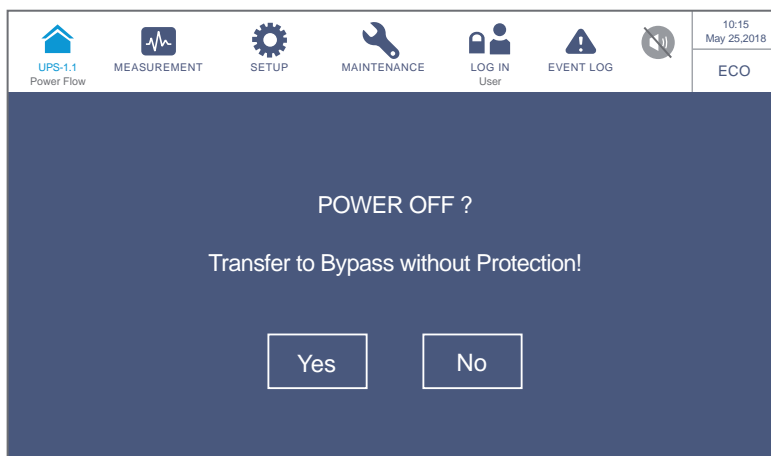

(Figure 6-53: Power Off Reminder Screen)

- 3 After selection of 'YES', the UPS will shut down the inverter, terminate each power module's output and let the bypass AC source supply power. If the bypass AC source is abnormal, there is a risk of output interruption and the connected critical loads won't be protected. At this moment, each power module keeps charging the batteries, the tri-color LED indicator illuminates yellow and the following screen appears. For the tri-color LED indicator location, please refer to **Figure 2-11**.

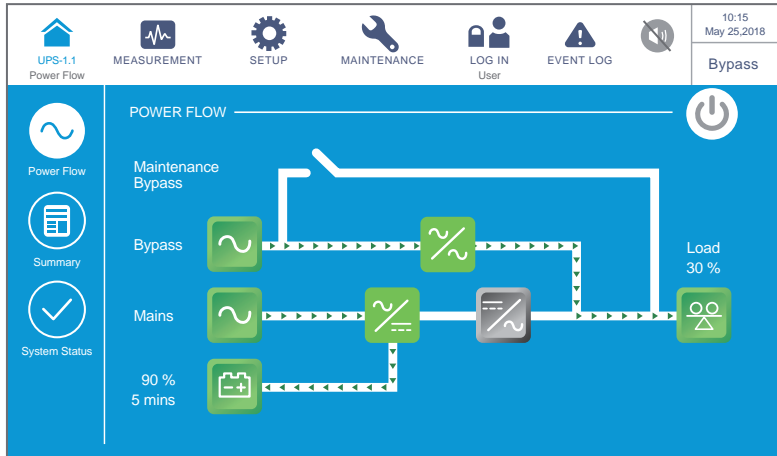

(Figure 6-54: Bypass Mode Screen)

- 4 Please log in as an **Administrator**. For the **Administrator** password, please contact service personnel. After login, ensure that you are in the **Administrator** login status (see **Figure 6-55**).

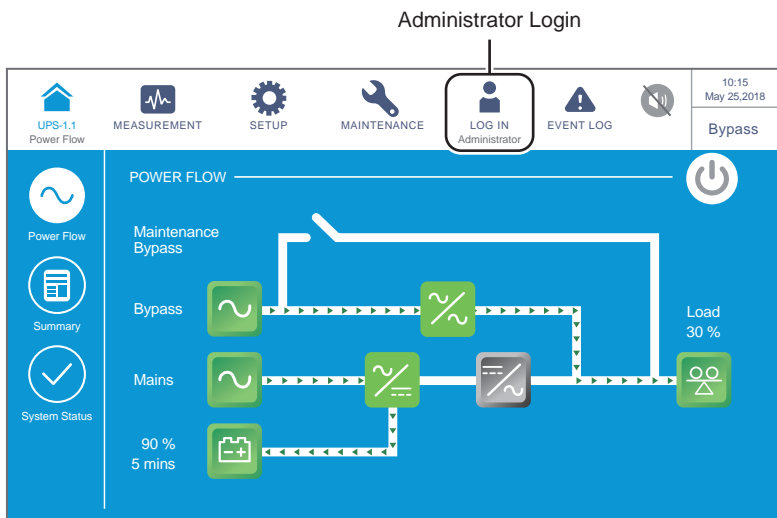

(Figure 6-55 : Bypass Mode Screen_ Administrator Login)

- 5 Click **SETUP** → **Mode Setting** → **On-Line**.

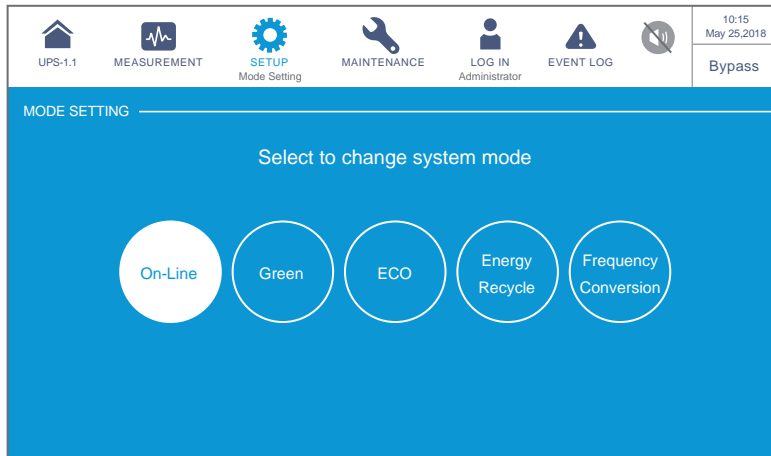

(Figure 6-56: Select Online Mode)

- 6 Switch **OFF** the Input/ Bypass Breaker (Q1) and Output Breaker (Q3). After that, the UPS will run in standby mode.
- 7 Now, each power module performs DC BUS discharging and its LED indicator flashes green. After discharging, each power module's LED indicator will be off.
- 8 About 3 minutes later, the UPS will shut down and the LCD and the tri-color LED indicator will be off.
- 9 Switch **OFF** every external battery cabinet's breaker.

6.3.6 Frequency Conversion Mode Turn-off Procedures



WARNING:

1. For parallel units, ensure that every operation procedure mentioned below is simultaneously executed and performed to all of the parallel UPSs.
 2. For parallel application, if you just want to operate a specific UPS but not all parallel ones, please contact service personnel.
- 1 In frequency conversion mode, the LCD shows the following screen and the tri-color LED indicator illuminates green. For the tri-color LED indicator location, please refer to **Figure 2-11**.

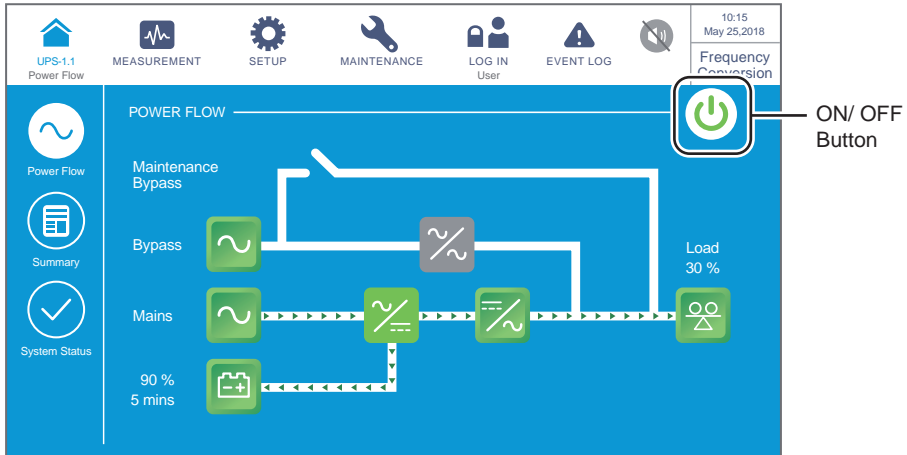

(Figure 6-57: Frequency Conversion Mode Screen & ON/ OFF Button Location)

- 2 Press the ON/ OFF button () once and the following screen will pop up to ask you if you want to power off the inverter. Please select 'YES'.



WARNING:

Please note that, once you select 'YES', all power will be completely cut off. Please make sure the critical loads connected to the UPS have already been safely shut down before you perform the turn-off procedures.

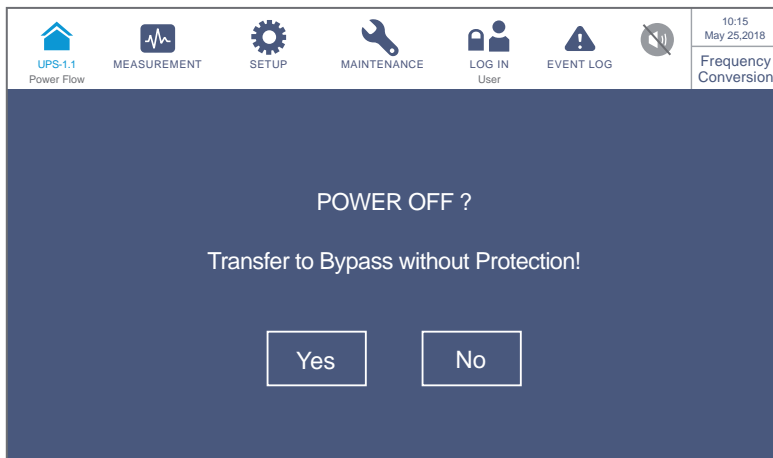

(Figure 6-58: Power Off Reminder Screen)

- 3 After selection of 'YES', the UPS will shut down the inverter and terminate each power module's output. As there is no bypass output in frequency conversion mode, all output will be terminated right after the inverter is shut down. Now, each power module keeps charging the batteries, the tri-color LED indicator illuminates yellow and the following screen appears. For the tri-color LED indicator location, please refer to **Figure 2-11**.

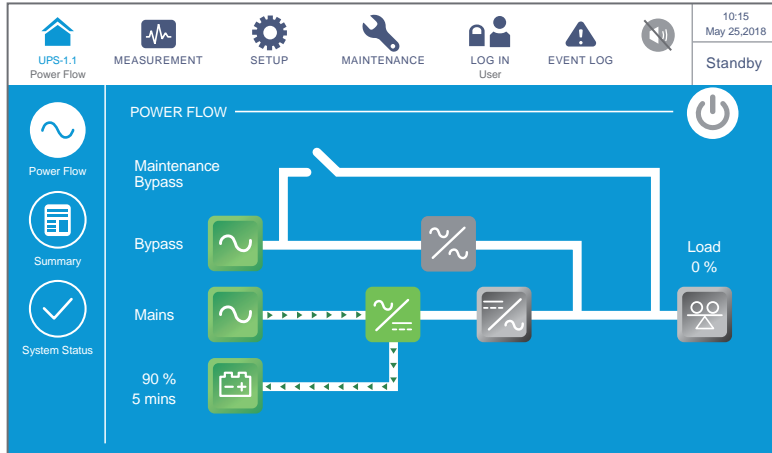

(Figure 6-59: Standby Mode Screen)

- 4 Switch **OFF** the Output Breaker (Q3) and log in as an **Administrator**. For the **Administrator** password, please contact service personnel. After login, ensure that you are in the **Administrator** login status (see **Figure 6-60**).

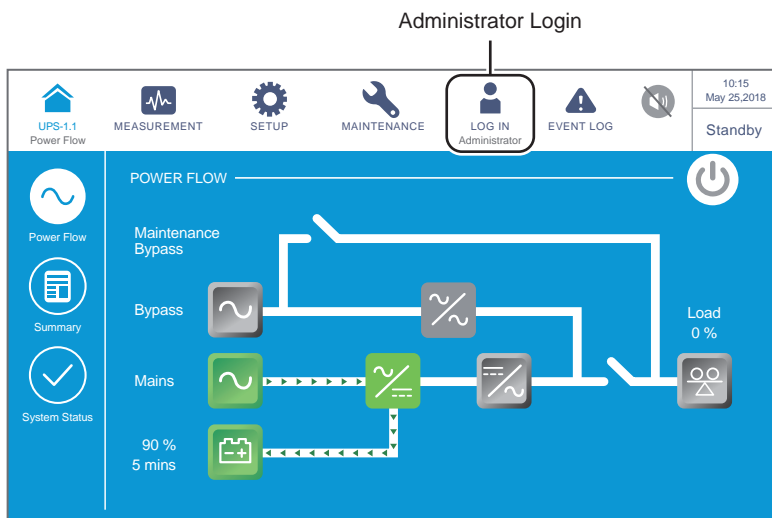

(Figure 6-60 : Standby Mode Screen_ Administrator Login)

- 5 Click **SETUP** → **Mode Setting** → **On-Line**. If the bypass voltage is in the normal range, the UPS will run in bypass mode to let the bypass AC source supply power to the output.

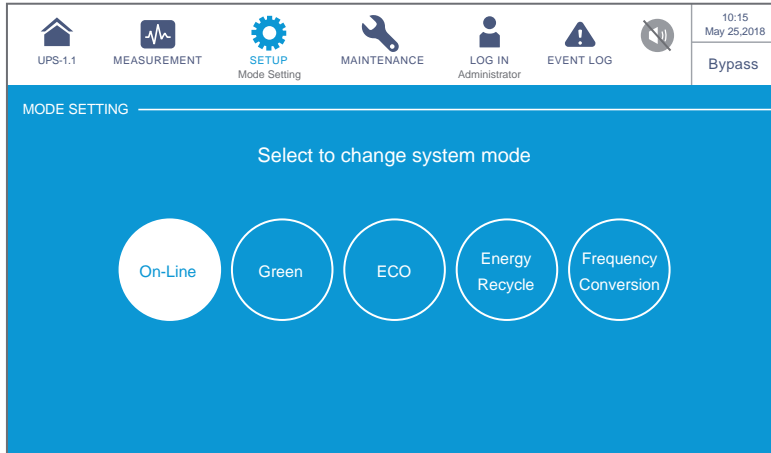

(Figure 6-61: Select Online Mode)

- 6 Switch **OFF** the Input/ Bypass Breaker (Q1). After that, the UPS will run in standby mode.
- 7 Now, each power module performs DC BUS discharging and its LED indicator flashes green. After discharging, each power module's LED indicator will be off.
- 8 About 3 minutes later, the UPS will shut down and the LCD and the tri-color LED indicator will be off.
- 9 Switch **OFF** every external battery cabinet's breaker.

6.3.7 Green Mode Turn-off Procedures

- 1 In green mode, the LCD shows the following screen and the tri-color LED indicator illuminates green. For the tri-color LED indicator location, please refer to **Figure 2-11**.

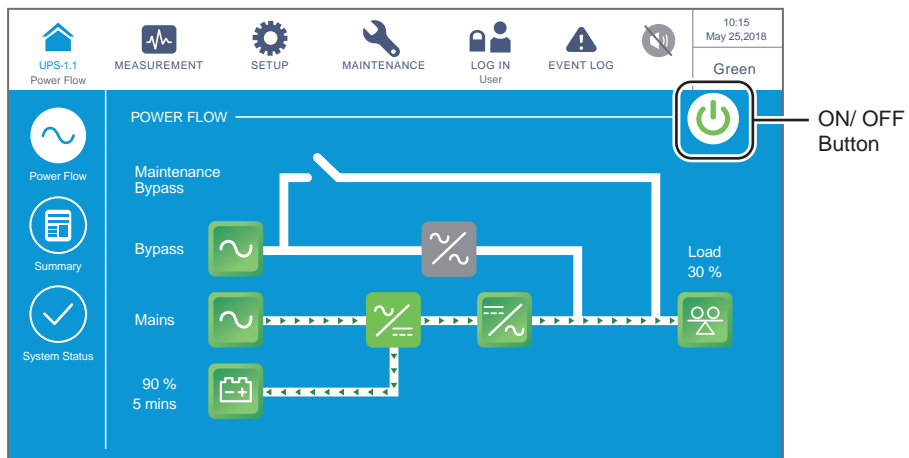

(Figure 6-62: Green Mode Screen & ON/ OFF Button Location)

- 2 Press the ON/ OFF button () once and the following screen will pop up to ask you if you want to power off the inverter. Check if the bypass voltage and STS module are normal or not. If normal, please select 'YES'.

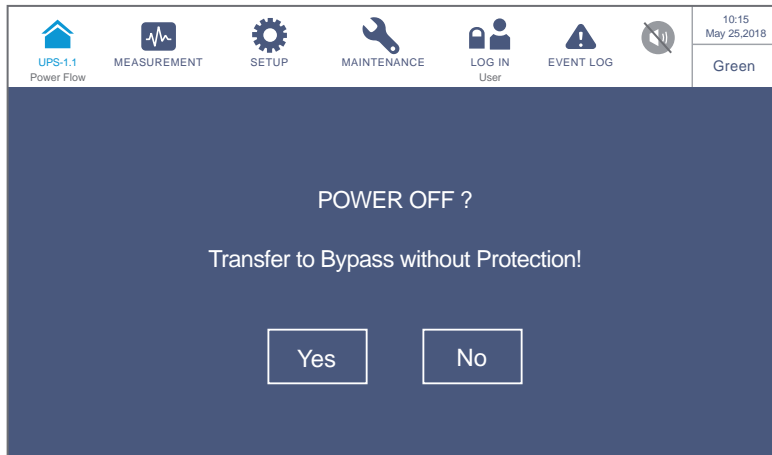

(Figure 6-63: Power Off Reminder Screen)

- 3 After selection of 'YES', the UPS will shut down each power module's output and let the bypass AC source supply power. If the bypass AC source is abnormal, there is a risk of output interruption and the connected critical loads won't be protected. At this moment, each power module keeps charging the batteries, the tri-color LED indicator illuminates yellow and the following screen appears. For the tri-color LED indicator location, please refer to **Figure 2-11**.

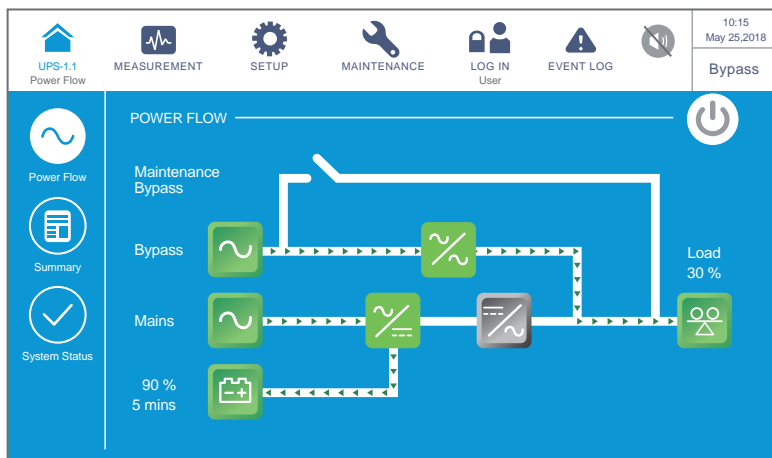

(Figure 6-64: Bypass Mode Screen)

- 4 Please log in as an **Administrator**. For the **Administrator** password, please contact service personnel. After login, ensure that you are in the **Administrator** login status (see **Figure 6-65**).

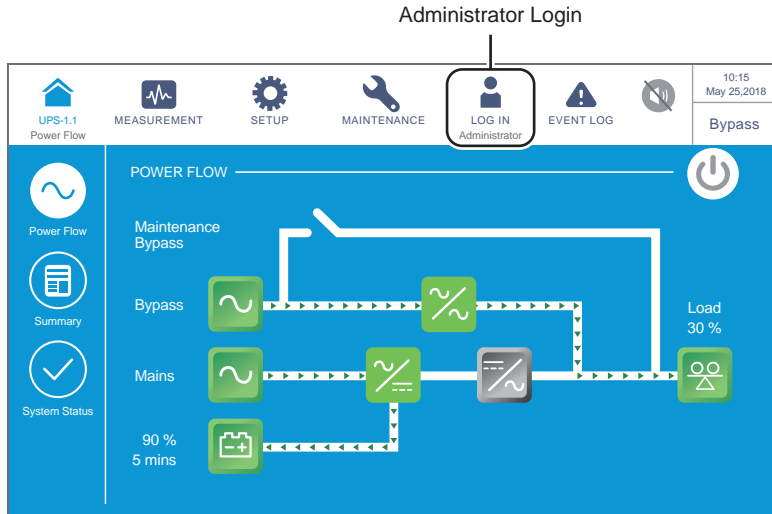

(Figure 6-65 : Bypass Mode Screen_ Administrator Login)

- 5) Click **SETUP** → **Mode Setting** → **On-Line**. If the bypass voltage is in the normal range, the UPS will run in bypass mode to let the bypass AC source supply power to the output.

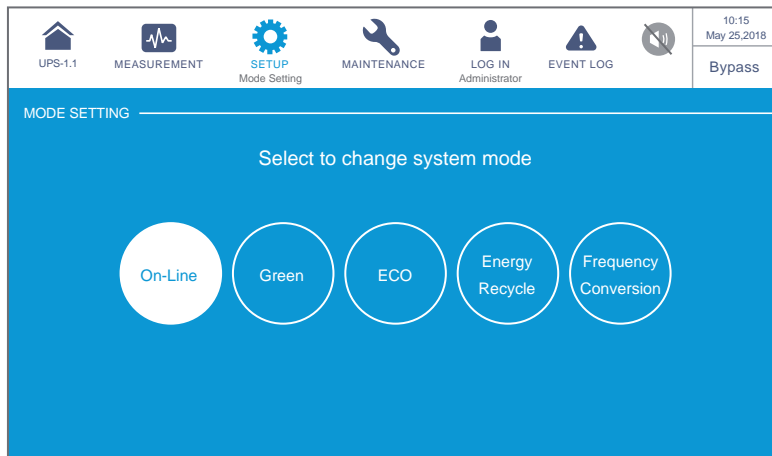

(Figure 6-66: Select Online Mode)

- 6) Switch **OFF** the Input/ Bypass Breaker (Q1) and Output Breaker (Q3). After that, the UPS will run in standby mode.
- 7) Now, each power module performs DC BUS discharging and its LED indicator flashes green. After discharging, each power module's LED indicator will be off.
- 8) About 3 minutes later, the UPS will shut down and the LCD and the tri-color LED indicator will be off.
- 9) Switch **OFF** every external battery cabinet's breaker.

6.3.8 Energy Recycle Mode Turn-off Procedures



WARNING: Energy recycle mode is only applicable to single input and single unit application.

- 1 In energy recycle mode, the LCD shows the following screen and the tri-color LED indicator illuminates yellow. For the tri-color LED indicator location, please refer to **Figure 2-11**.

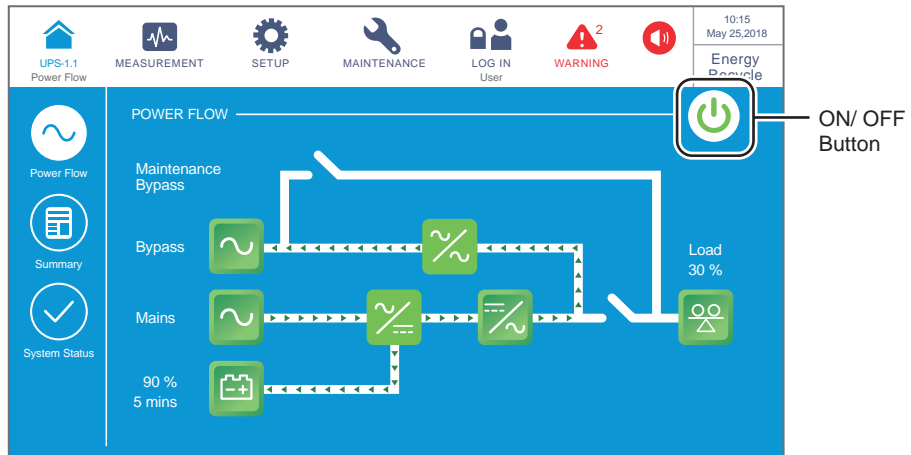

(Figure 6-67: Energy Recycle Mode Screen & ON/ OFF Button Location)

- 2 Press the ON/ OFF button () once and the following screen will pop up to ask you if you want to power off the inverter. Check if the bypass voltage and STS module are normal or not. If normal, please select 'YES'.

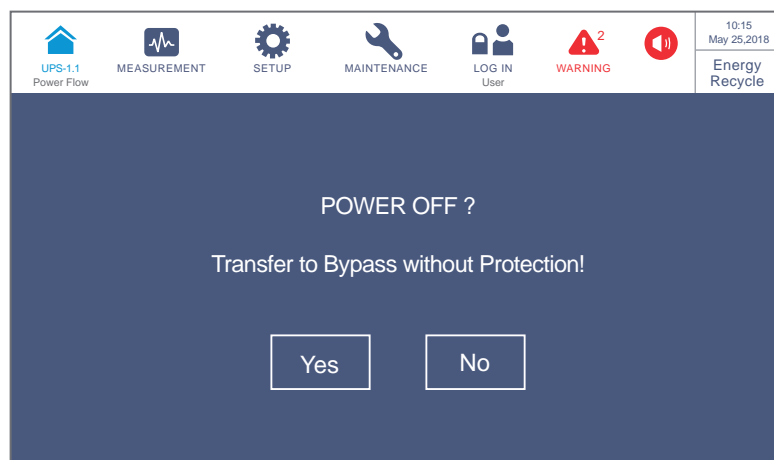

(Figure 6-68: Power Off Reminder Screen)

- 3 After selection of 'YES', the UPS will stop self-aging test and transfer to run in bypass mode. At this moment, the tri-color LED indicator illuminates yellow and the following screen appears. For the tri-color LED indicator location, please refer to **Figure 2-11**.

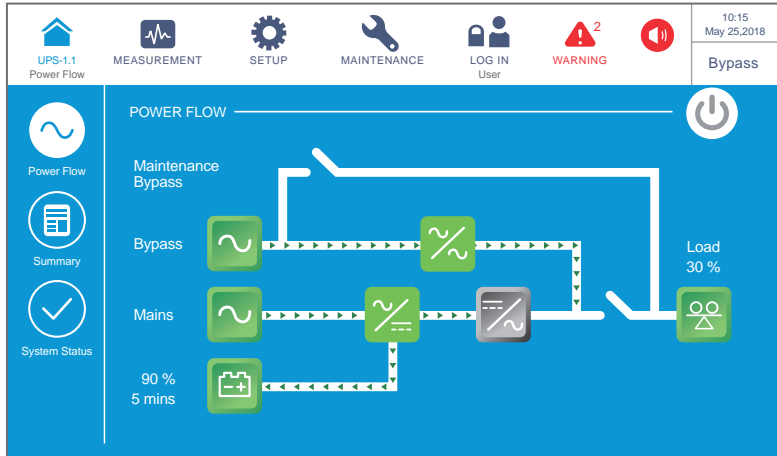

(Figure 6-69: Bypass Mode Screen)

- 4 Please log in as an **Administrator**. For the **Administrator** password, please contact service personnel. After login, ensure that you are in the **Administrator** login status (see **Figure 6-70**).

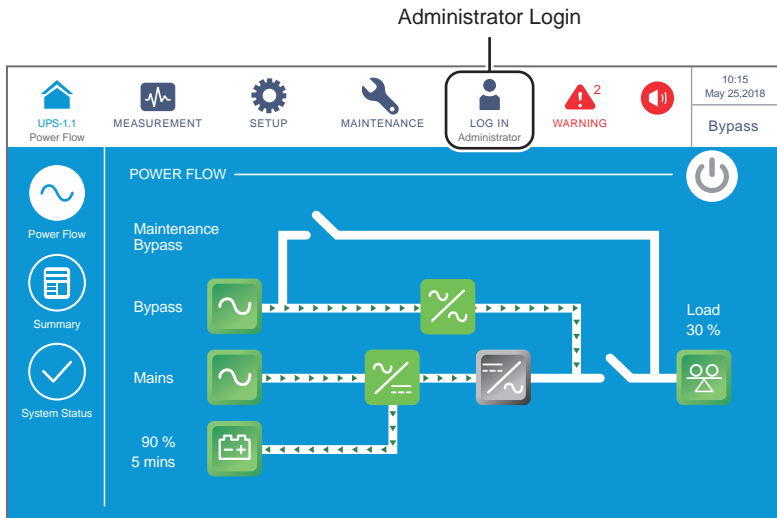

(Figure 6-70 : Bypass Mode Screen_ Administrator Login)

- 5 Click **SETUP** → **Mode Setting** → **On-Line**. If the bypass voltage is in the normal range, the UPS will run in bypass mode to let the bypass AC source supply power to the output.

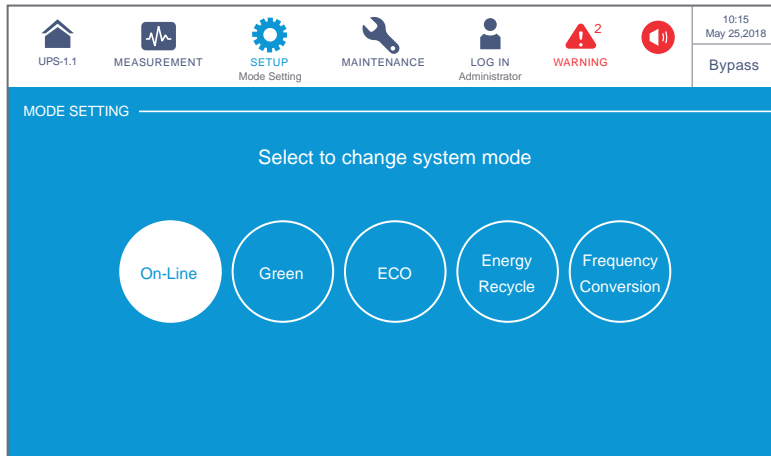

(Figure 6-71: Select Online Mode)

- 6 Switch **OFF** the Input/ Bypass Breaker (Q1) and Output Breaker (Q3). After that, the UPS will run in standby mode.
- 7 Now, each power module performs DC BUS discharging and its LED indicator flashes green. After discharging, each power module's LED indicator will be off.
- 8 About 3 minutes later, the UPS will shut down and the LCD and the tri-color LED indicator will be off.
- 9 Switch **OFF** every external battery cabinet's breaker.

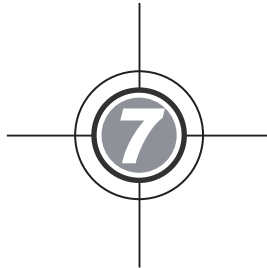

LCD Display & Settings

- 7.1 LCD Display Hierarchy
- 7.2 How to Turn on the LCD
- 7.3 ON/ OFF Button
- 7.4 LCD and Function Key Introduction
- 7.5 Password Entry
- 7.6 Main Screen
- 7.7 Main Menu
- 7.8 Power Flow & Summary & System Status
- 7.9 Check System Readings
- 7.10 UPS Settings
- 7.11 System Maintenance

7.1 LCD Display Hierarchy

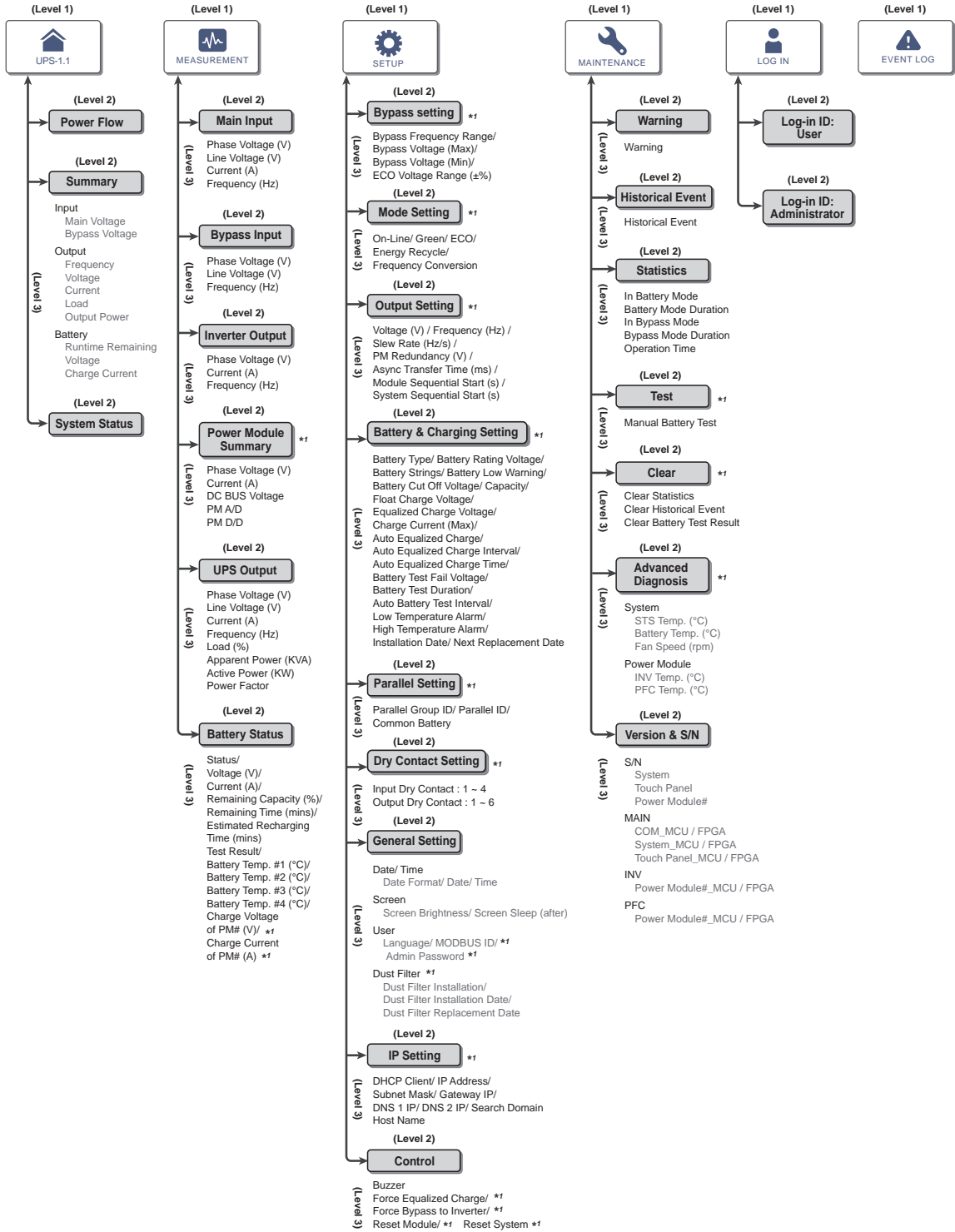

(Figure 7-1 : LCD Display Hierarchy)

**NOTE:**

1. *1 means that **ADMINISTRATOR** password is needed. For password information, please refer to **7.5 Password Entry**.
2. All unit No., UPS status, date, time, warning No., event No., load (%), battery remaining time, user login, administrator login, etc. shown in the LCD diagrams presented in **7. LCD Display and Settings** are for reference only. Actual readings depend on the operation of the UPS.
3. For how to turn on the LCD, please refer to **7.2 How to Turn on the LCD** and **7.3 ON/ OFF Button**.

7.2 How to Turn on the LCD

To turn on the LCD, please follow the steps below:

- 1 a. Turn on the Input/ Bypass Breaker (Q1) and the LCD will be on and LCD initial screen will appear; or
- b. Turn on the external battery cabinet's breaker, open the UPS front door and press any of the BATT. START buttons for 1 second. After that, the LCD will be on and LCD initial screen will appear. Please refer to **Figure 7-2** for the location of BATT. START buttons and **Figure 7-3** for the LCD initial screen.

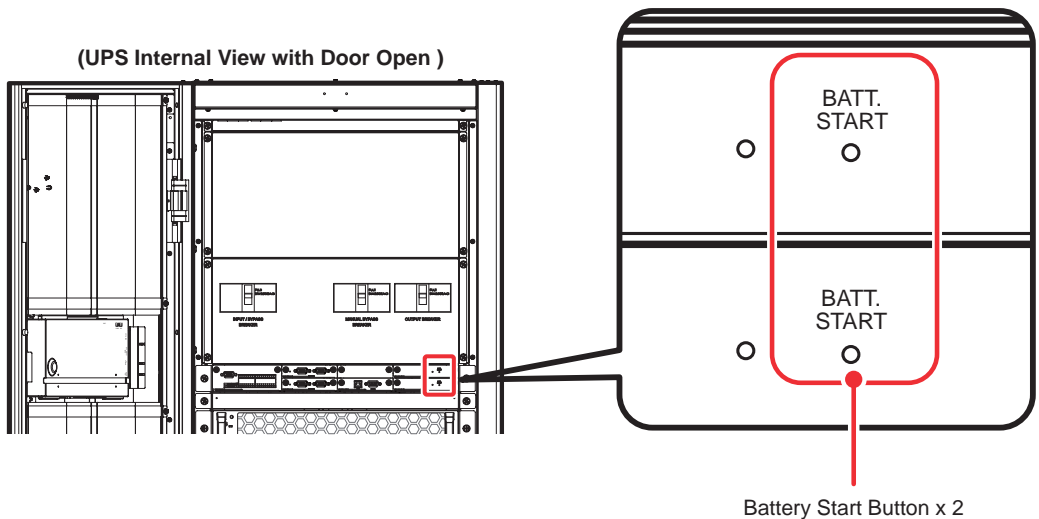

(Figure 7-2: BATT. START Button Location)



(Figure 7-3: LCD Initial Screen)

- 2 About 20 seconds after the LCD initial screen is on, the **Main Screen** will appear (see **Figure 7-4**). After you see the **Main Screen**, you can operate the LCD. Please note that the **Main Screen** appears in the **User** login status. Please refer to the figure below.

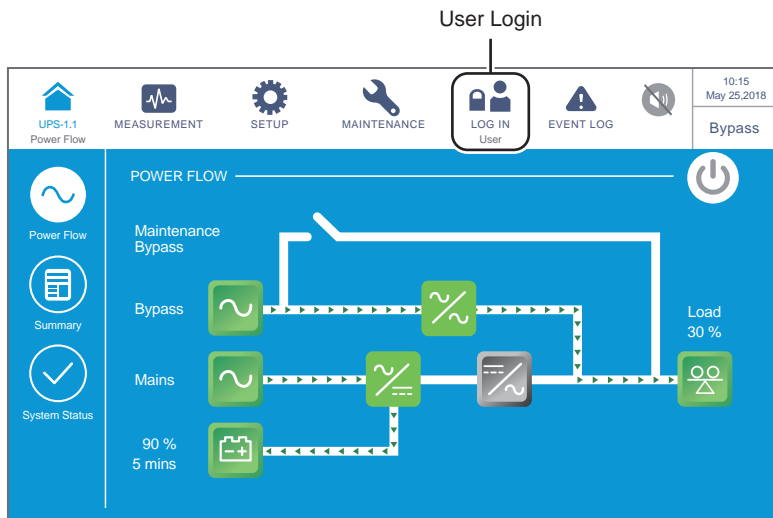

(Figure 7-4: Main Screen_ User Login)

7.3 ON/ OFF Button

After the touch panel is turned on in accordance with the steps stated in **7.2 How to Turn on the LCD**, the main screen will appear in the **User** login status and the ON/ OFF Button (🔌) will appear shown in **Figure 7-5**.

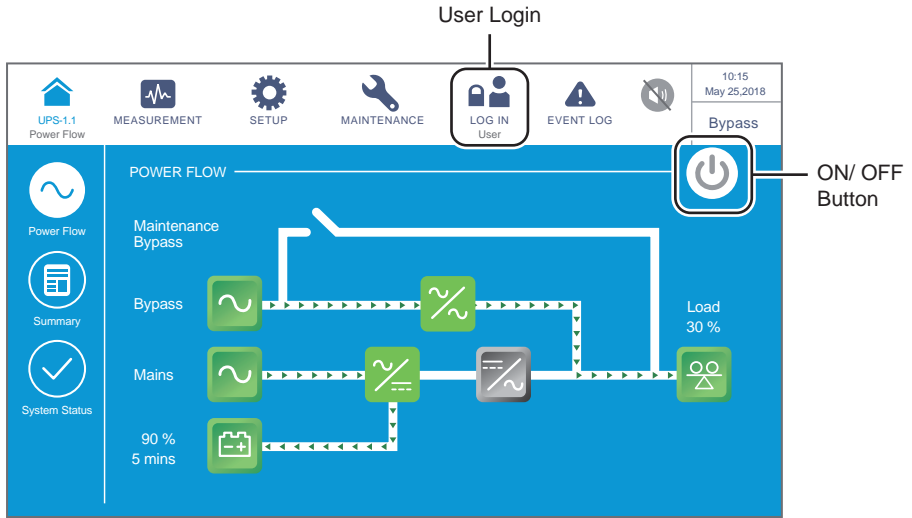

(Figure 7-5: Main Screen_ User Login & ON/ OFF Button)

• **Power On**

When the color of the ON/ OFF button (⏻) is gray, it means that the UPS's inverter is in the **OFF** status. If you press the button once, the following screen will pop up to ask you if you want to power on the UPS's inverter or not.

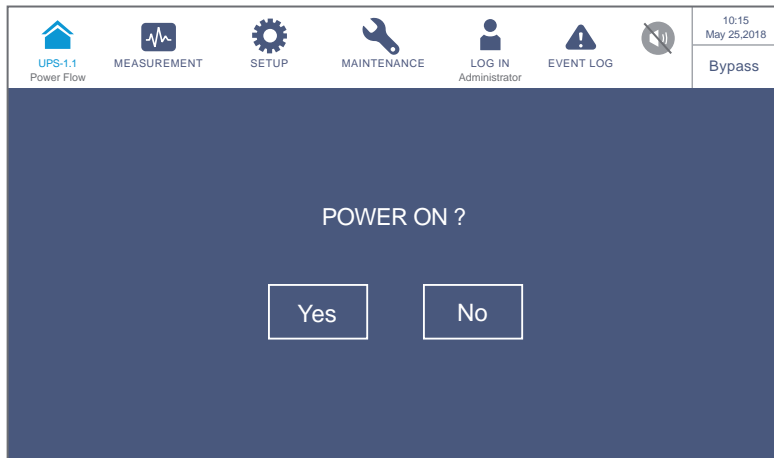

(Figure 7-6: Power On Reminder Screen)

After you select 'Yes', the color of the ON/ OFF button (⏻) will change to green and the UPS's inverter will be on.

- **Power Off**

When the color of the ON/ OFF button (🔌) is green, it means that the UPS's inverter is in the **ON** status. If you press the button once, the following screen will pop up to ask you if you want to power off the UPS's inverter or not.

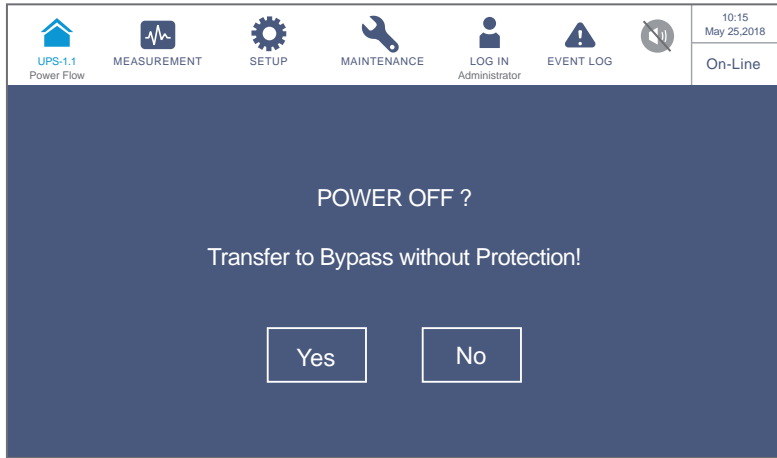







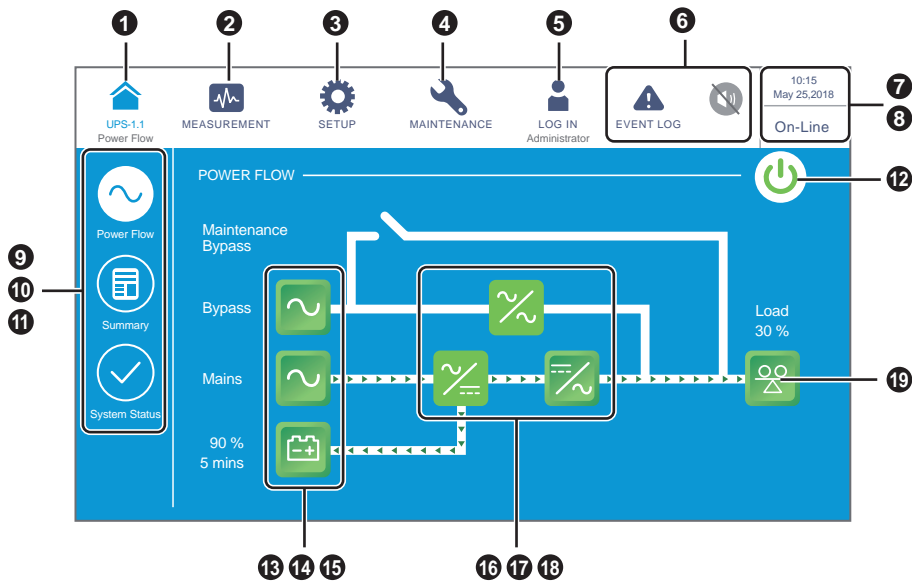

(Figure 7-7: Power Off Reminder Screen)











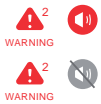

After you select 'Yes', the color of the ON/ OFF button (🔌) will change to gray and the UPS's inverter will be off.









7.4 LCD and Function Key Introduction

















(Figure 7-8: LCD and Function Key Introduction)

No.	Icon/ Text	Button Function (Yes or No)	Text/ Figure Display (Yes or No)	Symbol Display (Yes or No)	Description
①	 UPS-1.1	✓	✓		<p>Main Screen shortcut button. The No. UPS-1.1 shown below the icon  means the UPS's parallel group ID and parallel ID.</p> <p> NOTE: If you parallel the UPSs, press the button to choose which UPS's Main Screen that you want to check. For the master UPS, you can check its every status and readings; for the slave UPS, you can only check its partial status and partial readings. For UPS parallel information and application, please contact Delta service personnel.</p>
②	 MEASUREMENT	✓			Measurement menu shortcut button. Please refer to 7.9 Check System Readings for more information.
③	 SETUP	✓			Setup menu shortcut button. Please refer to 7.10 UPS Settings for more information.
④	 MAINTENANCE	✓			Maintenance menu shortcut button. Please refer to 7.11 System Maintenance for more information.
⑤	 LOG IN User	✓		✓	It means that you are in the User login status. You can press the button to change your login permission. Please refer to 7.5 Password Entry for more information.
	 LOG IN Administrator	✓		✓	It means that you are in the Administrator login status. You can press the button to change your login permission. Please refer to 7.5 Password Entry for more information.

No.	Icon/ Text	Button Function (Yes or No)	Text/ Figure Display (Yes or No)	Symbol Display (Yes or No)	Description
6		✓		✓	<ol style="list-style-type: none"> 1. Event log shortcut button (). 2. When the color of the warning icon () is blue, it means that there is no warning.
		✓	✓	✓	<ol style="list-style-type: none"> 1. Warning event shortcut button (). 2. Buzzer button (). 3. When the color of the warning icon () is red, it means that there is a warning. When a warning occurs, the buzzer will sound and the buzzer icon () will illuminate red. The number shown above the warning icon () means the total warning event No. If you press the buzzer icon () once, you can disable the buzzer. When the buzzer is disabled, the buzzer disabled icon () will appear.
7	10:15 May 25,2018		✓		Indicates the time and date.
8	On-Line ECO Frequency Conversion Green Energy Recycle Bypass Battery Standby Softstart		✓		Indicates the UPS's operation status (the actual display depends on the actual operation of the UPS).
9		✓			Power flow shortcut button. Press the button to check the UPS operation status and power flow diagram. Please refer to 7.8 Power Flow & Summary & System Status for more information.
10		✓			Summary shortcut button. Press the button to check the UPS input, output and battery status. Please refer to 7.8 Power Flow & Summary & System Status for more information.

No.	Icon/ Text	Button Function (Yes or No)	Text/ Figure Display (Yes or No)	Symbol Display (Yes or No)	Description
11		✓			System status shortcut button. Press the button to check the status of STS module, power module, battery module, parallel communication card, system control card and auxiliary power card. Please refer to 7.8 Power Flow & Summary & System Status for more information.
12		✓		✓	ON/ OFF button. Please refer to 7.3 ON/ OFF Button for more information.
13		✓		✓	<ol style="list-style-type: none"> 1. Bypass input status (green: normal; red: abnormal). 2. Bypass input screen shortcut button
14		✓		✓	<ol style="list-style-type: none"> 1. Main input status (green: normal; red: abnormal). 2. Main input screen shortcut button.
15		✓	✓	✓	<ol style="list-style-type: none"> 1. Battery status (green: normal; red: abnormal). 2. Battery remaining capacity (%). 3. Battery remaining time (minutes). 4. Battery status screen shortcut button.
16				✓	Bypass static switch status (green: ON; gray: OFF).
17				✓	Rectifier status (green: normal; gray: waiting or OFF).
18		✓		✓	<ol style="list-style-type: none"> 1. Inverter status (green: normal; gray: waiting or OFF). 2. Inverter output screen shortcut button.
19		✓	✓	✓	<ol style="list-style-type: none"> 1. Output status (green: normal; gray: no output). 2. Load capacity (%). 3. Output screen shortcut button.

Other icons that might appear when you operate the LCD include:

No.	Icon	Function
1		Goes to the top page.
		
2		Goes to the last page.
3		Moves up.
		
4		Moves down.
		
5		Increases number.
6		Decreases number.
7		Indicates the page No.
8		Deletes the number/ word.
		
9		Caps Lock.
10		Space.





NOTE:

1. When the LCD backlight is off, you can touch the screen to wake it up. The LCD will go back to the **Main Screen**. For information about the **Main Screen**. Please refer to **7.6 Main Screen**.
2. The backlight sleep time can be adjusted. Please refer to **7.10.7 General Setting**.
3. If you are logged in as an **Administrator** (the **Administrator** password is required; please refer to **7.5 Password Entry**), you will be logged out when the backlight is off. After you touch the screen to wake it up, the LCD will go back to the **Main Screen** in the **User** login status. Even if you set up the backlight in '**Never Sleep**' mode, you will still be logged out after the screen is idle for 5 minutes.

- The language default setting is English. If you want to change the default setting, please go to () → **General Setting** → **User** → **Language** to change your setting. The language default setting may be different according to different countries.

7.5 Password Entry

- Only **Administrator** login requires password entry. If you are logged in as a **User**, there is no need to enter the password.
- Click the icon () → enter the **Administrator** password (please contact service personnel for the default password) → the icon () appears, which means that you are successfully logged in as an **Administrator**.
- To change the password, please go to () → **General Setting** → **User** → **Admin Password** (four digits).



NOTE: Different login IDs (Administrator/ User) have different access to different screens, inspection items and setup items. Please refer to **7.1 LCD Display Hierarchy**.

7.6 Main Screen

- Please refer to **7.2 How to Turn on the LCD** and **7.3 ON/ OFF Button** to enter the **Main Screen**.
- The system shows different power flow screens depending on the status of the UPS. Each power flow screen is a **Main Screen**. See the examples below.

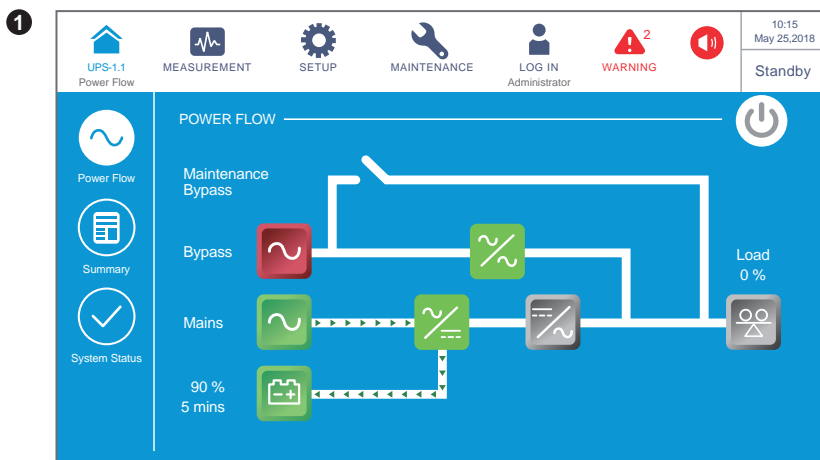

The screen above indicates that the UPS is in standby mode. The inverter is not turned on and the bypass is out of the range.

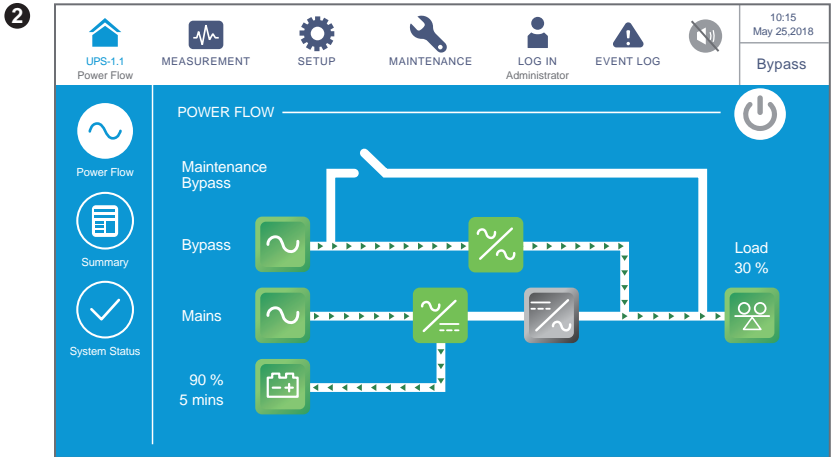

The screen above indicates that the UPS is in bypass mode. The inverter is not turned on.

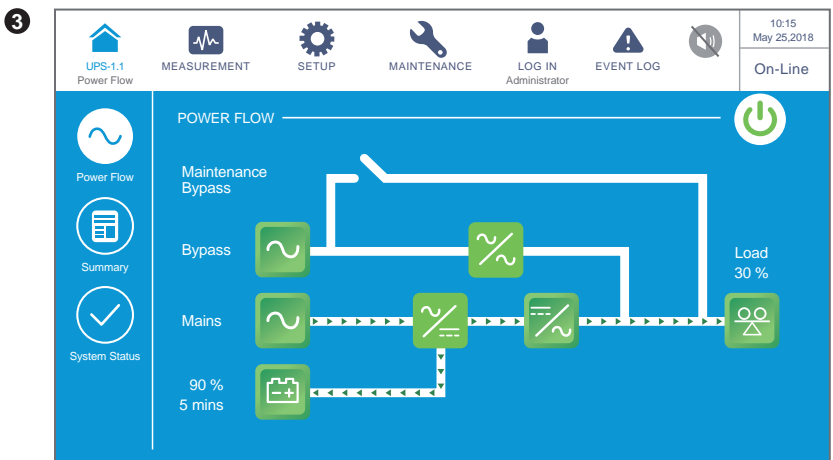

The screen above indicates that the UPS is running in online mode and the loads are supplied by the inverter. Please refer to **7.10.2 Mode Setting** and **6.2.1 Online Mode Start-up Procedures**.

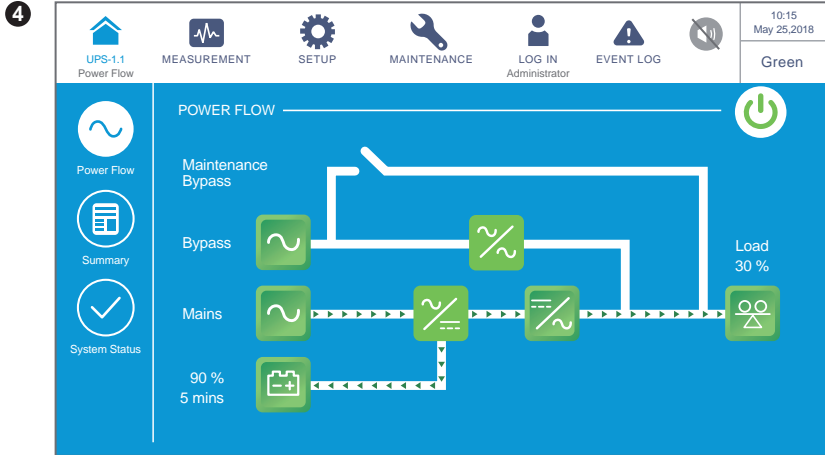

The screen above indicates that the UPS is in green mode. The loads are supplied by the inverter and the power modules take turn to turn off in accordance with the load situation. For green mode settings, please refer to **7.10.2 Mode Setting** and **6.2.7 Green Mode Start-up Procedures**.

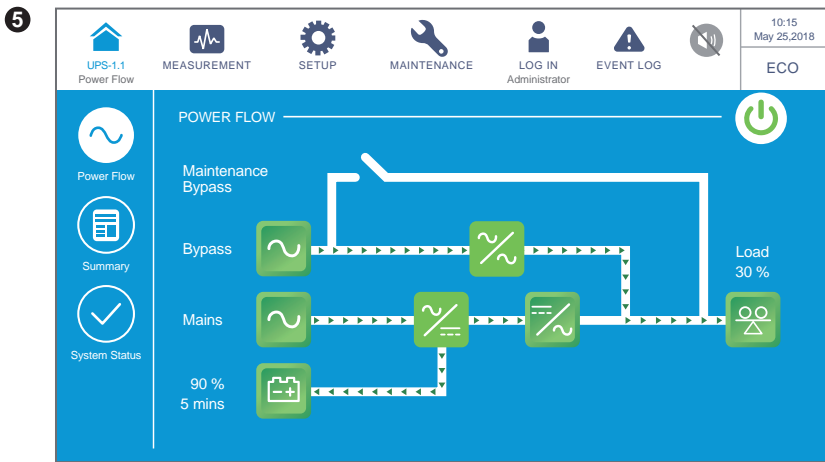

The screen above indicates that the UPS is in ECO mode. The inverter is in the ready-to-power-on status, and the loads are supplied by the bypass. For ECO mode settings, please refer to **7.10.2 Mode Setting** and **6.2.5 ECO Mode Start-up Procedures**.

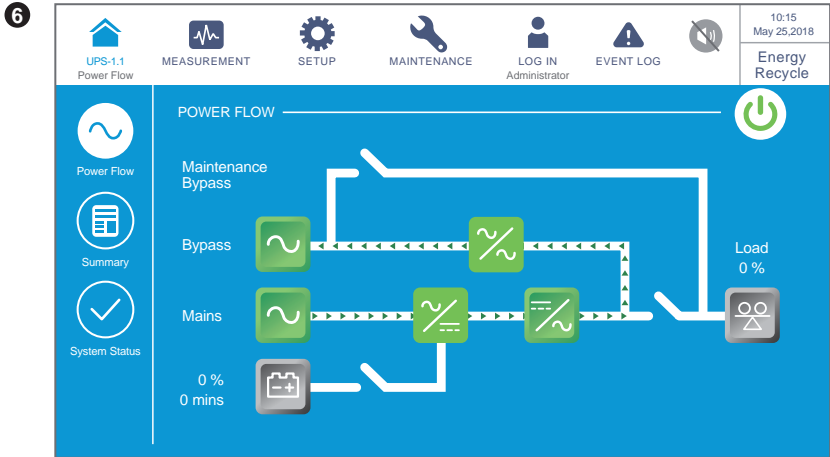

The screen above indicates that the UPS is in energy recycle mode. The output power will be recycled to the input without being sent to the loads, and the aging test could be conducted. For energy recycle mode settings, please refer to **7.10.2 Mode Setting** and **6.2.8 Energy Recycle Mode Start-up Procedures**.

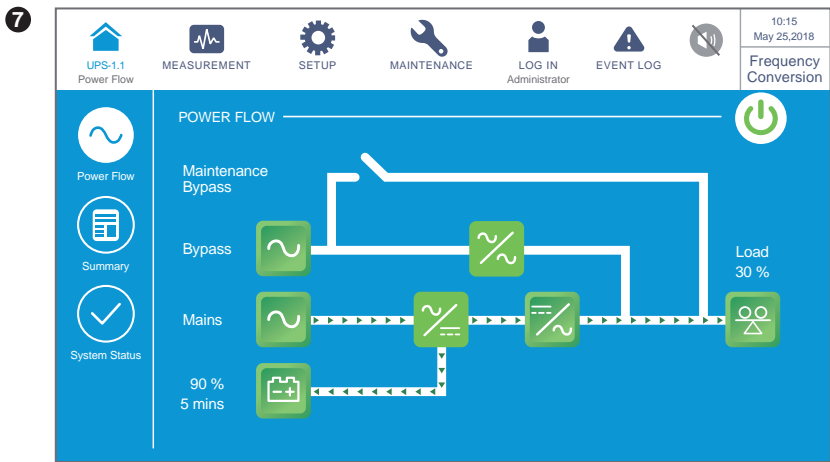

The screen above indicates that the UPS is in frequency conversion mode. The bypass output is restricted. For frequency conversion mode settings, please refer to **7.10.2 Mode Setting** and **6.2.6 Frequency Conversion Mode Start-up Procedures**.

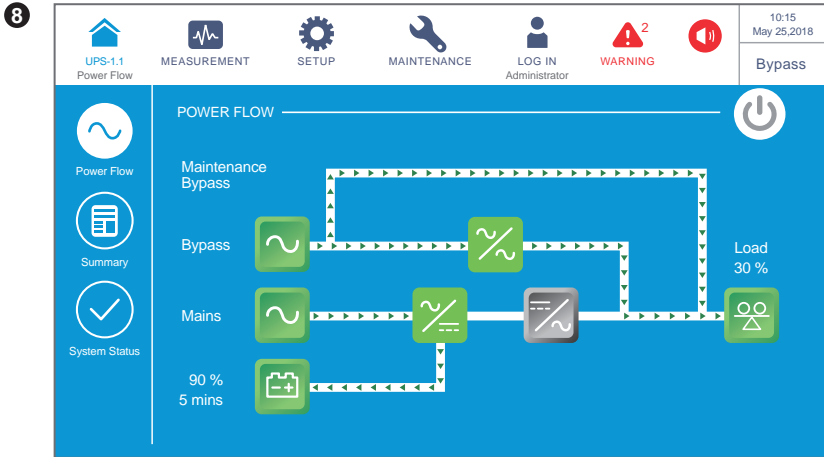



After the manual bypass breaker (Q2) is turned on, the UPS will be switched to manual bypass mode and the screen above will appear. Before maintenance personnel perform maintenance, the UPS must be switched to this mode and it must be ensured that all input power and battery power are disconnected. After power disconnection, the LCD will be off. If the bypass has any abnormalities, there will be no power supplying to the loads and the loads won't be protected. Please refer to **6.2.4 Manual Bypass Mode Start-up Procedures**.

7.7 Main Menu

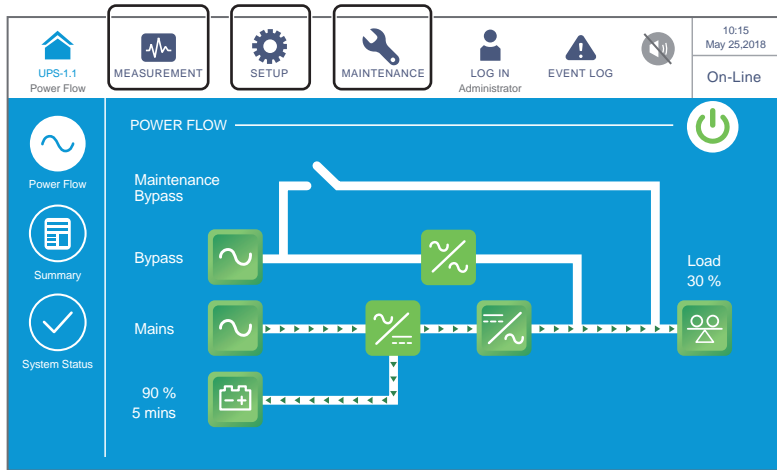
There are three main menu buttons ,  and . Please refer to the figure below.



(Figure 7-9: Main Menu Buttons)

Main Menu Button	Description
 MEASUREMENT	<p>Press the button to go to the Measurement Menu. In the menu, you can check the UPS's readings including the following:</p> <ol style="list-style-type: none"> 1. Main Input 2. Bypass Input 3. Inverter Output 4. Power Module Summary 5. UPS Output 6. Battery Status <p>For more information, please refer to 7.9 Check System Readings.</p>
 SETUP	<p>Press the button to go to the Setup Menu. In the menu, you can set up the following settings.</p> <ol style="list-style-type: none"> 1. Bypass Setting 2. Mode Setting 3. Output Setting 4. Battery & Charging Setting 5. Parallel Setting 6. Dry Contact Setting 7. General Setting 8. IP Setting 9. Control <p>For more information, please refer to 7.10 UPS Settings.</p>
 MAINTENANCE	<p>Press the button to go to the Maintenance Menu. In the menu, you can (1) check the warning events/ historical events/ statistics/ relevant temperature readings/ firmware version, (2) execute the manual battery test, (3) clear the statistics/ historical event/ battery test result, and (4) upgrade firmware.</p> <p>In the Maintenance Menu, it includes the following items.</p> <ol style="list-style-type: none"> 1. Warning 2. Historical Event 3. Statistics 4. Test 5. Clear 6. Advanced Diagnosis 7. Version & S/N <p>For more information, please refer to 7.11 System Maintenance.</p>



NOTE: Different login IDs (Administrator/ User) have different access to different screens, inspection items and setup items. Please refer to **7.1 LCD Display Hierarchy**.

7.8 Power Flow & Summary & System Status

There are three shortcut buttons for you to check the power flow, summary, and system status respectively. Please see the figure below.

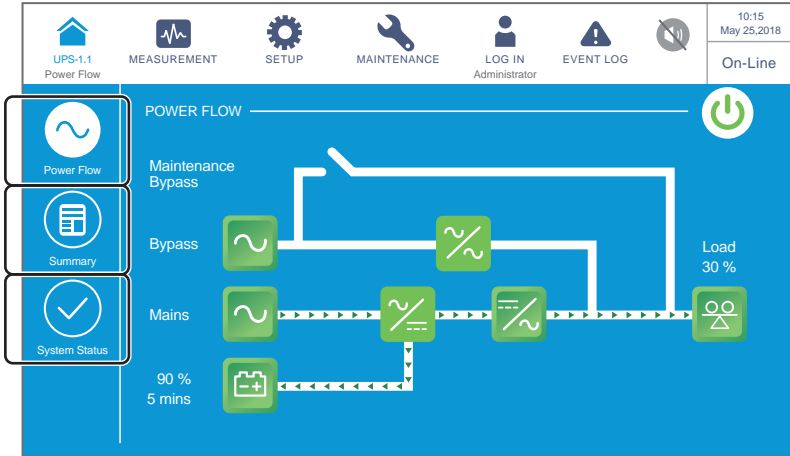

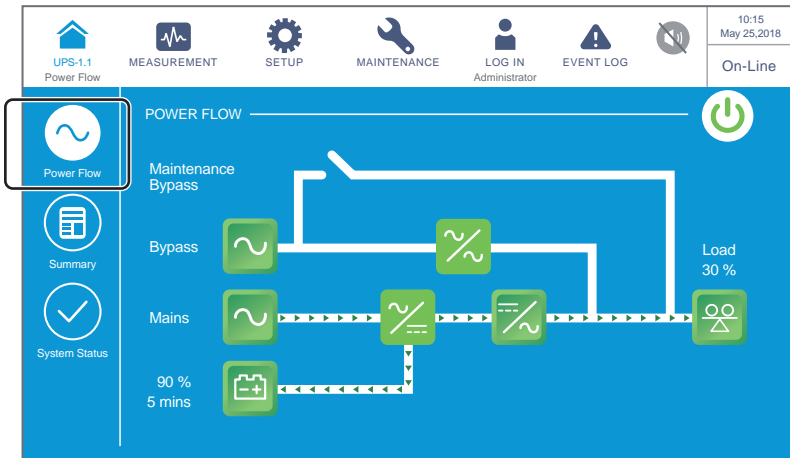

(Figure 7-10: Power Flow & Summary & System Status Shortcut Buttons)

Press the  button to check the UPS's power flow diagram. Please refer to the figure below.

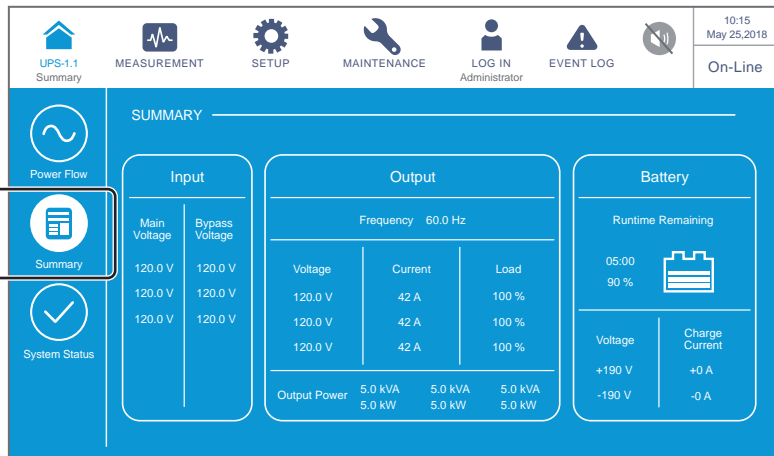

Press the  button to check the UPS's input, output and battery status. Please refer to the figure below.



Press the  button to check the status of STS module, power module, battery module, parallel communication card, system control card and auxiliary power card. Please refer to the figure below.

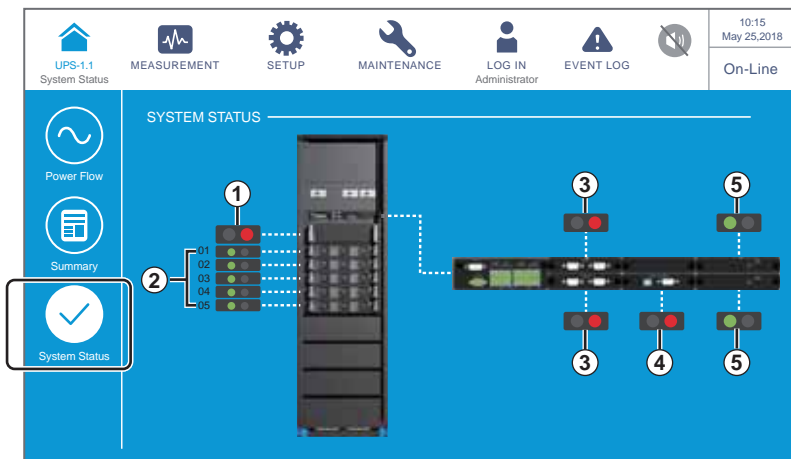

- ① STS Module Status
- ② Power Module Status
- ③ Parallel Communication Card Status
- ④ System Control Card Status
- ⑤ Auxiliary Power Card Status

7.9 Check System Readings

7.9.1 Main Input

Route:  → Main Input

In the **MAIN INPUT** screen shown below, you can check the **Phase Voltage**, **Line Voltage**, **Current** and **Frequency**.

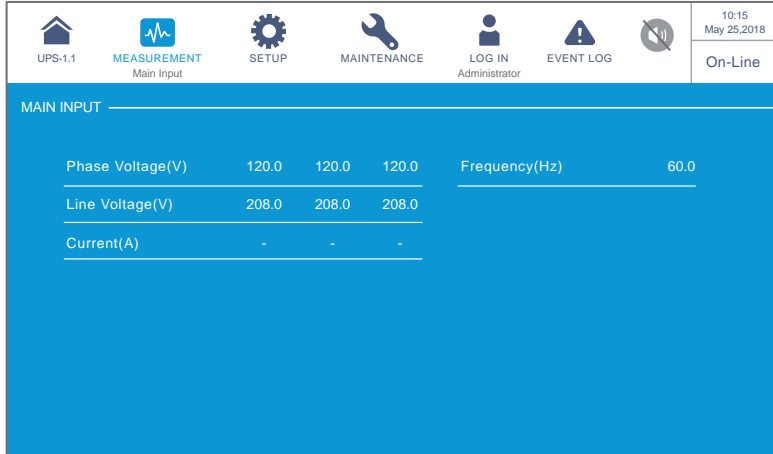

7.9.2 Bypass Input

Route:  → Bypass Input

In the **BYPASS INPUT** screen shown below, you can check the **Phase Voltage**, **Line Voltage** and **Frequency**.

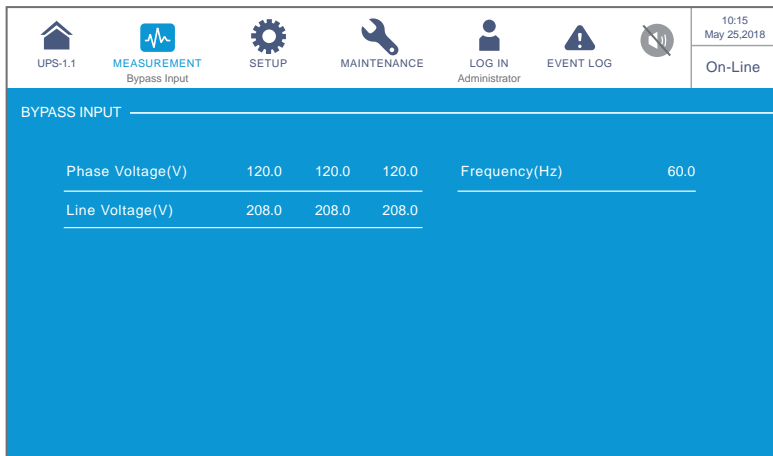

7.9.3 Inverter Output

Route:  → Inverter Output

In the **INVERTER OUTPUT** screen shown below, you can check a specific power module's **Phase Voltage, Current and Frequency**.

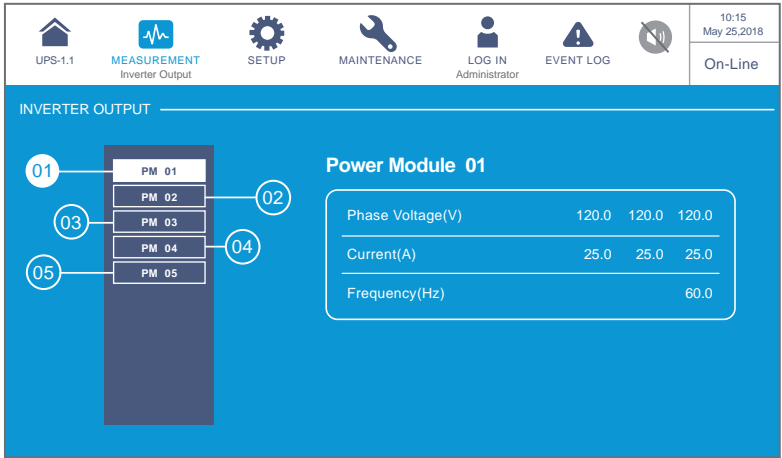

7.9.4 Power Module Summary

Route:  → Power Module Summary

In the **POWER MODULE SUMMARY** screen shown below, you can check each power module's **Phase Voltage, Current, DC BUS Voltage, PM A/D** and **PM D/D**.









Power Module#	1	2	3	4	5
Phase Voltage(V)	120.0 120.0 120.0	120.0 120.0 120.0	120.0 120.0 120.0	120.0 120.0 120.0	120.0 120.0 120.0
Current(A)	25.0 25.0 25.0	25.0 25.0 25.0	25.0 25.0 25.0	25.0 25.0 25.0	25.0 25.0 25.0
DC BUS Voltage	190.0 190.0	190.0 190.0	190.0 190.0	190.0 190.0	190.0 190.0
PM A/D	On	On	On	On	On
PM D/D	Off	Off	Off	Off	Off

7.9.5 UPS Output

Route:  → UPS Output







In the **UPS OUTPUT** screen shown below, you can check the **Phase Voltage, Line Voltage, Current, Frequency, Load, Apparent Power, Active Power and Power Factor**.

 UPS-1.1	 MEASUREMENT UPS Output	 SETUP	 MAINTENANCE	 LOG IN Administrator	 EVENT LOG		10:15 May 25, 2018
							On-Line
UPS OUTPUT							
Phase Voltage(V)	120.0	120.0	120.0	Apparent Power(KVA)	5	5	5
Line Voltage(V)	208.0	208.0	208.0	Active Power(KW)	5	5	5
Current(A)	41.6	41.6	41.6	Power Factor	1	1	1
Frequency(Hz)	60.0						
Load(%)	100%	100%	100%				

7.9.6 Battery Status

Route:  → Battery Status

In the **BATTERY STATUS** screen shown below, you can check the **Status, Voltage, Current, Remaining Capacity, Remaining Time, Estimated Recharging Time, Test Result, Battery Temperature (#1-#4)**, and each power module's **Charge Voltage** and **Charge Current**.

 UPS-1.1	 MEASUREMENT Battery Status	 SETUP	 MAINTENANCE	 LOG IN Administrator	 EVENT LOG		10:15 May 25, 2018
							On-Line
BATTERY STATUS							
				PAGE 1	PAGE 2		
Status	None			Test Result	None		
Voltage(V)	+ 190.4	- 190.4		Battery Temp. #1 (°C)	-		
Current(A)	+ 0	- 0		Battery Temp. #2 (°C)	-		
Remaining Capacity (%)	90			Battery Temp. #3 (°C)	-		
Remaining Time (mins)	05:00			Battery Temp. #4 (°C)	-		
Estimated Recharging Time (mins)	00:00						

UPS-1.1

MEASUREMENT
Battery Status

SETUP

MAINTENANCE

LOG IN
Administrator

EVENT LOG

10:15
May 25,2018
On-Line

PAGE
1

PAGE
2

Power Module#	1	2	3	4	5
Charge Voltage of PM# (V)	+190.4 -190.4	+190.4 -190.4	+190.4 -190.4	+190.4 -190.4	+190.4 -190.4
Charge Current of PM# (A)	+1.0 -1.0	+1.0 -1.0	+1.0 -1.0	+1.0 -1.0	+1.0 -1.0

7.10 UPS Settings

7.10.1 Bypass setting

Route: → **Bypass Setting**

In the **BYPASS SETTING** screen shown below, you can set up the bypass frequency range, bypass voltage (Max.), bypass voltage (Min.) and ECO voltage range. If the range is exceeded, the system will issue an alarm. Only qualified service personnel can perform the above-mentioned setup items. Please contact Delta customer service for assistance.

UPS-1.1

MEASUREMENT

SETUP
Bypass setting

MAINTENANCE

LOG IN
Administrator

EVENT LOG

10:15
May 25,2018
Bypass

BYPASS SETTING

Bypass Frequency Range

± Hz

Bypass Voltage(Max)

+ %

Bypass Voltage(Min)

- %

ECO Voltage Range(±%)

± %

Item	Description
Bypass Frequency Range	Set up the bypass output's frequency range.
Bypass Voltage (Max.)	Set up the bypass output's maximum voltage.
Bypass Voltage (Min.)	Set up the bypass output's minimum voltage.
ECO Voltage Range	Set up the bypass output's voltage range in ECO mode.

7.10.2 Mode Setting

Route:  → **Mode Setting**

In the **MODE SETTING** screen shown below, you can set up the UPS's operation mode. There are five selections, which are on-line, green, ECO, energy recycle and frequency conversion modes. Only qualified service personnel can perform the above-mentioned setup items. Please contact Delta customer service for assistance.

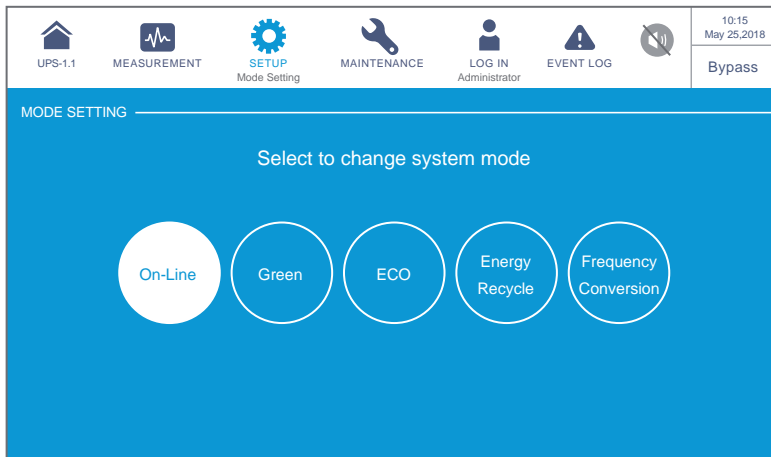

Item	Description
On-line Mode	Set up the UPS in on-line mode. In on-line mode, it is the inverter to supply power to the connected loads.
Green Mode	Set up the UPS in green mode. In green mode, it is the inverter to supply power to the connected loads and the power modules take turn to rest according to the situation of total load capacity.

Item	Description
ECO Mode	Set up the UPS in ECO mode. In ECO mode, it is the bypass to supply power to the connected loads. It is suggested that you set the UPS in ECO mode only when there is stable main AC power. Otherwise, power supply quality will be compromised.
Energy Recycle Mode	Set up the UPS in energy recycle mode. In energy recycle mode, the full load output can be simulated for the aging test without real output to the loads.
Frequency Conversation Mode	Set up the UPS in frequency conversation mode. In frequency conversation mode, it is the inverter to supply power to the connected loads with a fixed output frequency. Please note that the output will be terminated once the inverter is turned off.

7.10.3 Output Setting

Route:  → **Output Setting**

In the **OUTPUT SETTING** screen shown below, you can set up the following items. The settings must be carried out by qualified service personnel. Please contact Delta customer service for assistance.

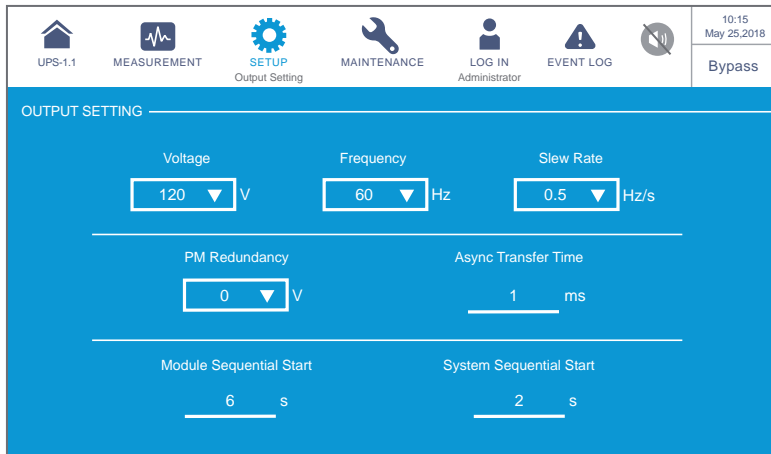

Item	Description
Voltage	Set up the output voltage.
Frequency	Set up the output frequency as 50Hz or 60Hz. The system will automatically select output frequency in accordance with the bypass power. When there is a bypass malfunction, this setting will serve as the reference.

Item	Description
Slew Rate	Set up the maximum permissible speed for the system output frequency to catch up the bypass frequency variation.
Power Module Redundancy	Set up how many power modules that need to be preserved for redundancy.
Asynchronous Transfer Time	When it is impossible for the inverter to reach synchronous phase lock with the bypass, the output will be terminated during conversion process according to this setup time.
Module Sequential Start	Set up the time interval for every power module to be converted from the battery mode to online mode. The setup is applicable to the generator to avoid bearing the whole loads right away.
System Sequential Start	Set up the time interval for the system to be converted from the battery mode to online mode. The setup is applicable to the generator to avoid bearing the whole loads right away.

7.10.4 Battery & Charging Setting

Route:  → **Battery & Charging Setting**

In the **BATTERY & CHARGING SETTING** screen shown below, you can set up the following items. The settings must be carried out by qualified service personnel. Please contact Delta customer service for assistance.

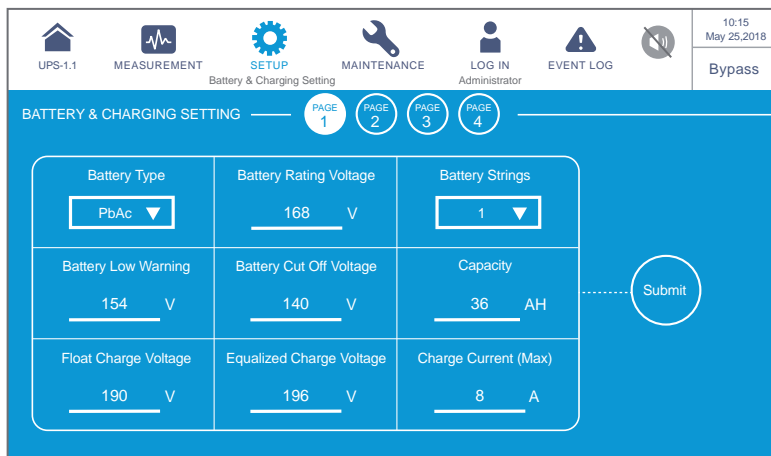

The screenshot shows the 'BATTERY & CHARGING SETTING' screen with the following configuration:

Setting	Value	Unit
Battery Type	PbAc	
Battery Rating Voltage	168	V
Battery Strings	1	
Battery Low Warning	154	V
Battery Cut Off Voltage	140	V
Capacity	36	AH
Float Charge Voltage	190	V
Equalized Charge Voltage	196	V
Charge Current (Max)	8	A

A 'Submit' button is located to the right of the settings grid.

UPS-1.1	MEASUREMENT	SETUP Battery & Charging Setting	MAINTENANCE	LOG IN Administrator	EVENT LOG		10:15 May 25, 2018 Bypass
---------	-------------	--	-------------	-------------------------	-----------	--	---------------------------------

BATTERY & CHARGING SETTING — PAGE 1 PAGE 2 PAGE 3 PAGE 4

Auto Equalized Charge: ▾

Auto Equalized Charge Interval: ▾

Auto Equalized Charge Time: min

UPS-1.1	MEASUREMENT	SETUP Battery & Charging Setting	MAINTENANCE	LOG IN Administrator	EVENT LOG		10:15 May 25, 2018 Bypass
---------	-------------	--	-------------	-------------------------	-----------	--	---------------------------------

BATTERY & CHARGING SETTING — PAGE 1 PAGE 2 PAGE 3 PAGE 4

Battery Test Fail Voltage: V

Battery Test Duration: min

Auto Battery Test Interval: ▾

UPS-1.1	MEASUREMENT	SETUP Battery & Charging Setting	MAINTENANCE	LOG IN Administrator	EVENT LOG		10:15 May 25, 2018 Bypass
---------	-------------	--	-------------	-------------------------	-----------	--	---------------------------------

BATTERY & CHARGING SETTING — PAGE 1 PAGE 2 PAGE 3 PAGE 4

Low Temperature Alarm: ▾ °C

Installation Date: ▾

High Temperature Alarm: ▾ °C

Next Replacement Date: ▾

Item	Description
Battery Type	Set up the battery type.
Battery Rating Voltage	Set up the battery rating voltage.
Battery Strings	Set up how many battery strings that are used on site.
Battery Low Warning	Set up the battery low warning voltage.
Battery Cut Off Voltage	Set up the battery low voltage. In battery mode, when the battery low voltage is reached, the battery power will cut off, the UPS will shut down, and the connected loads won't be protected.
Capacity	Set up the battery capacity.
Float Charge Voltage	Set up the float charge voltage.
Equalized Charge Voltage	Set up the equalized charge voltage.
Charge Current (Max.)	Set up the maximum charge current.
Auto Equalized Charge	Enable or disable the auto equalized charge.
Auto Equalized Charge Interval	Set up the auto equalized charge interval.
Auto Equalized Charge Time	Set up the auto equalized charge time.
Battery Test Fail Voltage	Set up the battery test fail voltage. When the battery voltage is under the test fail voltage, it means battery fail.
Battery Test Duration	Set up how long the battery test should last.
Auto Battery Test Interval	Set up the battery test interval.
Low Temperature Alarm	Enable or disable the low temperature alarm. If enabled, set up the temperature.
High Temperature Alarm	Enable or disable the high temperature alarm. If enabled, set up the temperature.
Installation Date	Record the battery installation date.
Next Replacement Date	Set up the battery replacement date.

7.10.5 Parallel Setting

Route:  → Parallel Setting

In the **PARALLEL SETTING** screen shown below, you can set up the following items. The settings must be carried out by qualified service personnel. Please contact Delta customer service for assistance.

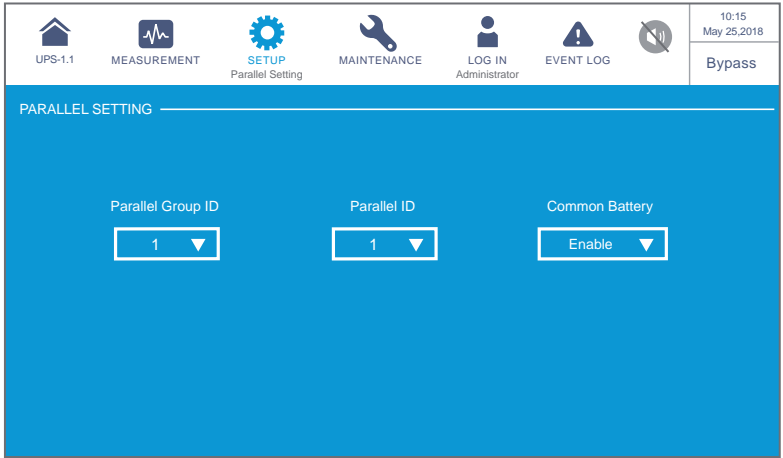

Item	Description
Parallel Group ID	The UPSs in parallel connection must be assigned the same parallel group ID No. in order to let the outputs of the parallel UPSs be put in parallel connection and let the loads be evenly distributed among the parallel units. If the parallel UPSs have different parallel group ID No., their output signals might be synchronized but their outputs cannot be connected in parallel.
Parallel ID	The UPSs that need to be paralleled must be assigned the same parallel group ID No. and different parallel ID No. in order to let the parallel function work.
Common Battery	If the parallel UPSs that have the same parallel group ID No. need to share common batteries, please select ' Enable ' for the ' Common Battery ' setup item. Otherwise, the function of battery abnormality detection will fail.

7.10.6 Dry Contact Setting

Route:  → Dry Contact Setting

In the **DRY CONTACT SETTING** screen shown below, you can set up the event, NO (normally open) or NC (normally closed) for each of the input and output dry contacts. Please refer to the table below. Please note that the settings must be carried out by qualified service personnel. Please contact Delta customer service for assistance.

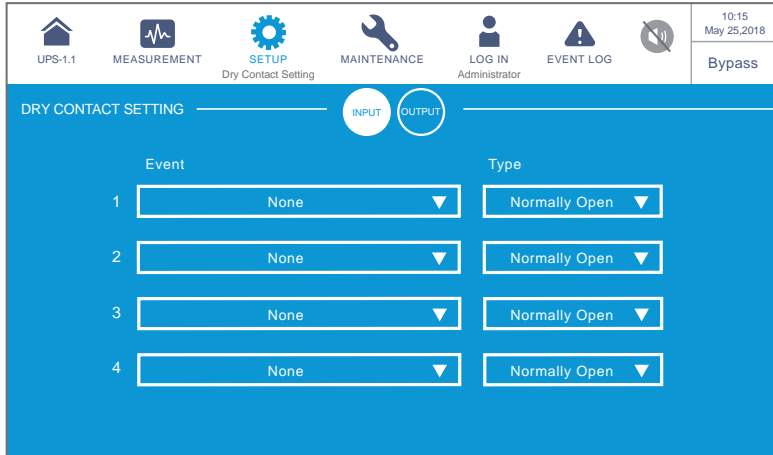

Input Dry Contact No.	Event Selection	Type
<p>Input Dry Contact 1 Input Dry Contact 2 Input Dry Contact 3 Input Dry Contact 4</p>	<p>You can select one of the following events as the setting for each input dry contact.</p> <ol style="list-style-type: none"> 1. None 2. Generator status 3. Battery ground fail 4. External battery breaker detection 	<p>You can set up NO (normally open) or NC (normally closed) for each input dry contact.</p>

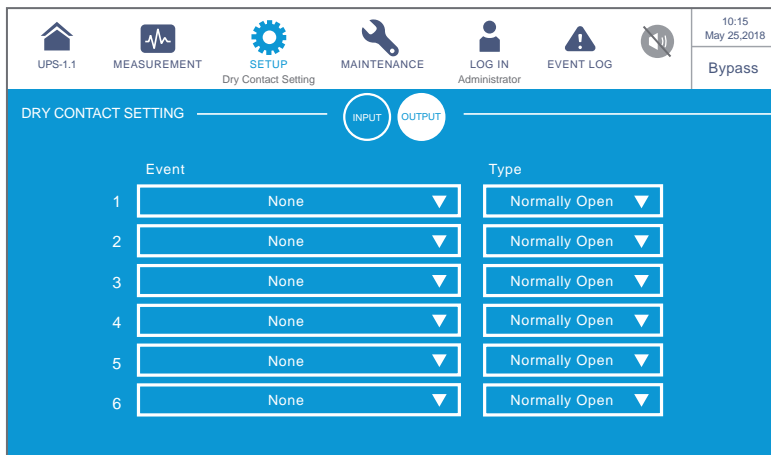

Output Dry Contact No.	Event Selection	Type
Output Dry Contact 1 Output Dry Contact 2 Output Dry Contact 3 Output Dry Contact 4 Output Dry Contact 5 Output Dry Contact 6	<p>You can select one of the following events as the setting for each output dry contact.</p> <ol style="list-style-type: none"> 1. None 2. Load on inverter 3. Load on bypass 4. Load on battery 5. Battery low 6. Battery input abnormal 7. Battery test fail 8. Internal comm. fail 9. External parallel comm. fail (only applicable to parallel application) 10. Output overload 11. EPO activated 12. Load on manual bypass 13. Battery over temperature 14. Output voltage abnormal 15. Battery need replacement 16. Bypass over temperature 17. Bypass static switch fault 18. UPS over temperature 19. Battery breaker shunt trip 20. Backfeed Protection 21. UPS general alarm 	<p>You can set up NO (normally open) or NC (normally closed) for each output dry contact.</p>

7.10.7 General Setting

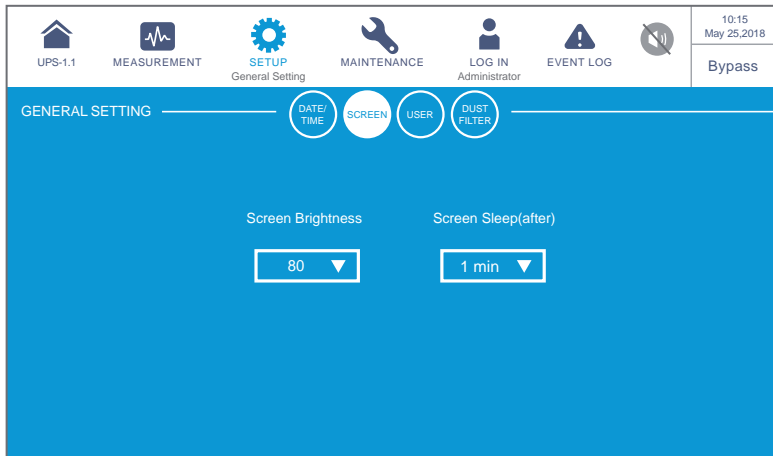
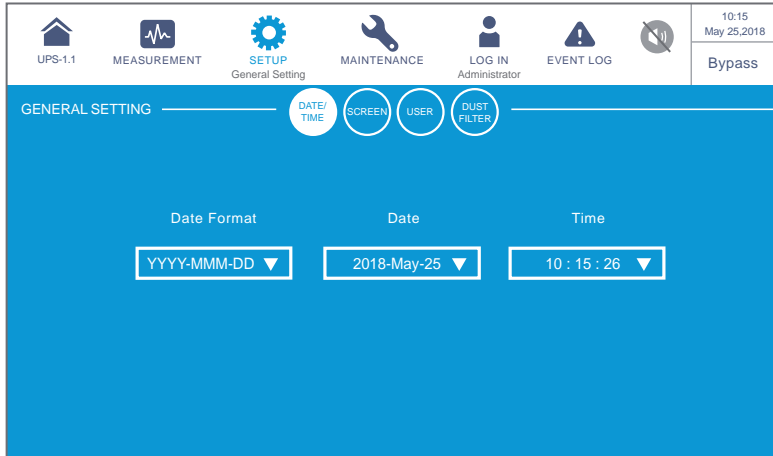

Route:  → General Setting

In the **GENERAL SETTING** screen shown below, you can set up the **DATE/ TIME**, **SCREEN**, **USER** and **DUST FILTER** relevant settings. For detailed information, please refer to the table below.

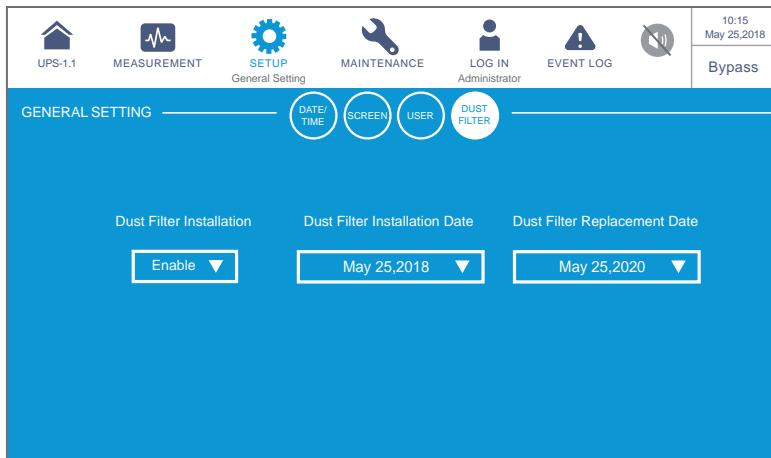
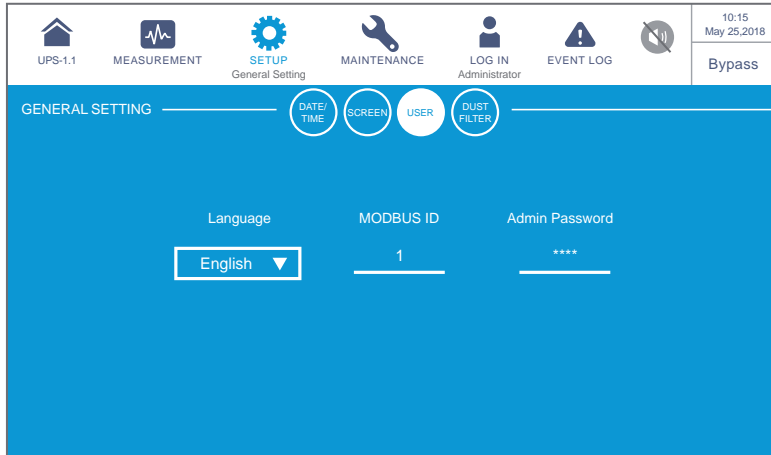



Item	Sub Item	Description
DATE/ TIME	Date Format	Select the date format.
	Date	Set up the date.
	Time	Set up the time.
SCREEN	Screen Brightness	Adjust the LCD display brightness (default: 80).
	Screen Sleep (after)	Set up the LCD backlight sleep time (default: 1 minute).
USER	Language	Set up the display language (default: English).
	MODBUS ID	Set up the MODBUS ID.
	Admin Password	Set up the administrator password (4 digits).

Item	Sub Item	Description
DUST FILTER	Dust Filter Installation	If you have installed any dust filter, please select ' Enable '; if not, please select ' Disable '.
	Dust Filter Installation Date	Set up the dust filter installation date.  NOTE: Only when you select ' Enable ' for ' Dust Filter Installation ' can you set up the ' Dust Filter Installation Date '.
	Dust Filter Replacement Date	Set up the dust filter replacement date. When the date is due, the red warning icon () will automatically appear in the upper right corner of the LCD, and the alarm message ' Replace Dust Filter ' will be displayed.  NOTE: Only when you select ' Enable ' for ' Dust Filter Installation ' can you set up the ' Dust Filter Replacement Date '.

7.10.8 IP Setting

Route:  → IP Setting

In the **IP SETTING** screen shown below, you can set up the following items. Please note that the settings must be carried out by qualified service personnel. Please contact Delta customer service for assistance.

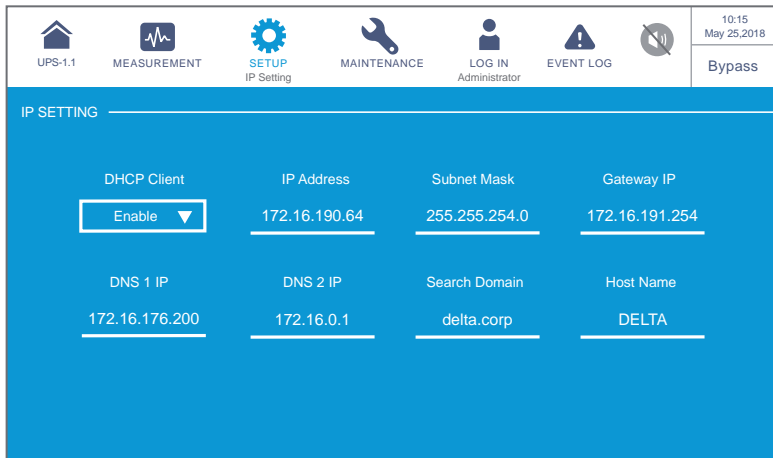

Item	Description
DHCP Client	Enable or disable the DHCP client.
IP Address	Set up the IP address.

Item	Description
Subnet Mask	Set up the subnet mask.
Gateway IP	Set up the gateway IP address.
DNS 1 IP	Set up the DNS server 1 IP address.
DNS 2 IP	Set up the DNS server 2 IP address.
Search Domain	Set up the search domain.
Host Name	Set up the host name.

7.10.9 Control

Route:  → **Control**

In the **CONTROL** screen shown below, you can set up the following items. Please note that the settings must be carried out by qualified service personnel. Please contact Delta customer service for assistance.

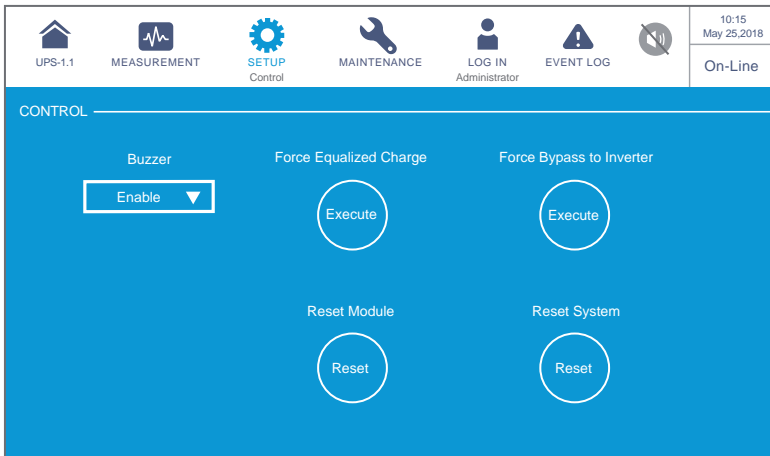

Item	Description
Buzzer	Enable or disable the buzzer.
Force Equalized Charge	Manually force the UPS to run in auto equalized charge mode to charge the batteries.
Force Bypass to Inverter	Manually force the UPS to switch from bypass to inverter when the inverter keeps staying in the soft-start status and is unable to transfer to on-line mode successfully.

Item	Description
Reset Module	Reset the power modules or not. In bypass mode, when you press the ON/ OFF button (⏻) to start up the UPS but the UPS does not respond, please select 'Reset' to reset the power modules. After the power modules are reset, please press the ON/ OFF button (⏻) to start up the UPS.
Reset System	Reset the system or not. In bypass mode, when you press the ON/ OFF button (⏻) to start up the UPS but the UPS does not respond, please select 'Reset' to reset the system. After the system is reset, please press the ON/ OFF button (⏻) to start up the UPS.

7.11 System Maintenance

7.11.1 Warning

Route 1:  MAINTENANCE → **Warning**

Route 2: When there is a warning, the buzzer icon (🔊) will illuminate red and the buzzer will make an alarm sound. Please click the warning icon (⚠️) to go to the **WARNING** screen.

In the **WARNING** screen shown below, you can use the buttons (⏪ ⏩ ⏴ ⏵) to check the warning logs or use the function key (1) to enter a specific page No. to view the warning logs. The system can store at maximum 200 warning logs.



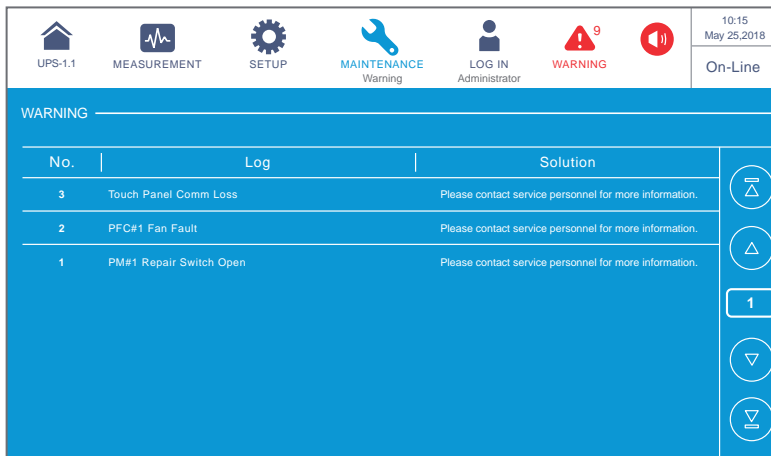

The **WARNING** screen also displays relevant solutions. For warning solutions, you can also refer to **10. Troubleshooting**.



7.11.2 Historical Event

















Route:  MAINTENANCE → **Historical Event**





The **HISTORICAL EVENT** screen shown below provides each historical event's No., start date and time, code (red: serious; orange: minor; green: normal), location, and log description. You can click the icon () to magnify the entire historical event description.

You can use the buttons (   ) to check the historical event logs or use the function key () to enter a specific page No. to view the historical event logs.

The system can save up to 10000 historical event logs. The greater the event number is, the newer the event is. When the total number of historical event logs exceeds the storage capacity (up to 10000 entries), the oldest 500 historical event logs will be overwritten.

You can click the download button () to download the historical event logs. To clear the historical event logs, please refer to **7.11.5 Clear**.

HISTORICAL EVENT						DOWNLOAD
No. ▲	Start Date	Code	Location	Log		
187	2018-05-13 10:27:07	● 3200-02	STS	Emergency PWR Off		
186	2018-05-13 10:26:52	● 2519-01	STS	CSU Aux Pwr #2 On Repair		
185	2018-05-13 10:26:36	● 2518-01	STS	CSU Aux Pwr #1 On Repair		
184	2018-05-13 09:06:59	● 0128-01	STS	Mains Input Freq Out Range		
183	2018-05-13 10:27:07	● 5005-01	STS	No Output		
182	2018-05-13 10:26:52	● 480A-01	STS	COM Card #2 Absent		
181	2018-05-13 10:26:36	● 0100-01	STS	Mains Input Volt Out Range		
180	2018-05-13 09:16:45	● 3200-01	STS	About Emergency PWR Off		

HISTORICAL EVENT						DOWNLOAD
No. ▲	Start Date	Code	Location	Log		
179	2018-05-13 09:06:59	● 480A-01	STS	Battery Disconnected		
178	2018-05-13 08:22:45	● 1021-01	STS	Mains Input Freq Out Range		
177	2018-05-13 08:10:06	● 2501-01	STS	Mains Input Volt Out Range		
176	2018-05-13 07:58:15	● 501F-01	STS	UPS Soft Start		
175	2018-05-13 07:48:22	● 5005-01	STS	No Output		
174	2018-05-13 07:35:10	● 480A-01	STS	COM Card #2 Absent		
173	2018-05-13 07:25:25	● 0100-01	STS	Mains Input Volt Out Range		
172	2018-05-13 07:15:02	● 3200-01	STS	About Emergency PWR Off		

7.11.3 Statistics

Route:  MAINTENANCE → **Statistics**

In the **STATISTICS** screen shown below, you can check the statistics.

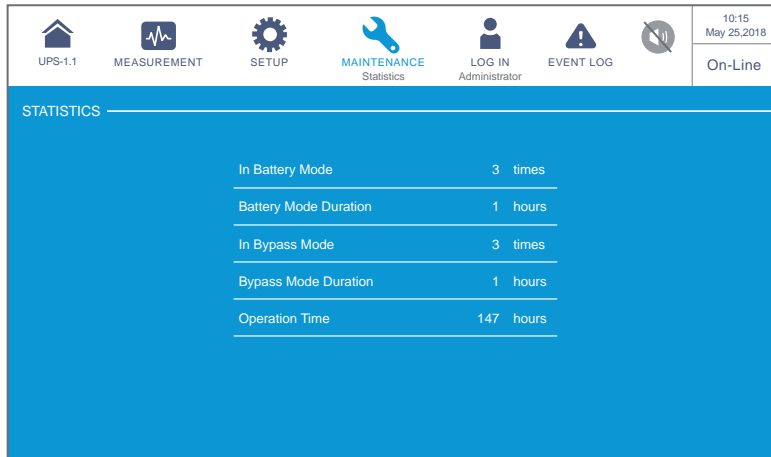

Item	Description
In Battery Mode	Means how many times that the UPS runs in battery mode.
Battery Mode Duration	Means how long the UPS runs in battery mode.
In Bypass Mode	Means how many times that the UPS runs in bypass mode.
Bypass Mode Duration	Means how long the UPS runs in bypass mode.
Operation Time	Means how long the UPS has operated.

To clear the statistics, please refer to **7.11.5 Clear**.

7.11.4 Test

Route:  MAINTENANCE → Test

In the **TEST** screen shown below, you can execute the manual battery test.

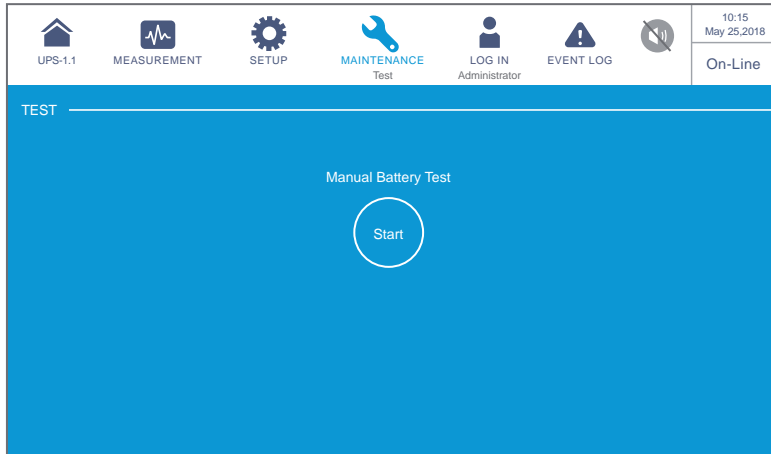

7.11.5 Clear

Route:  MAINTENANCE → Clear

In the **CLEAR** screen shown below, you can clear the records of (1) statistics, (2) historical event and (3) battery test result.

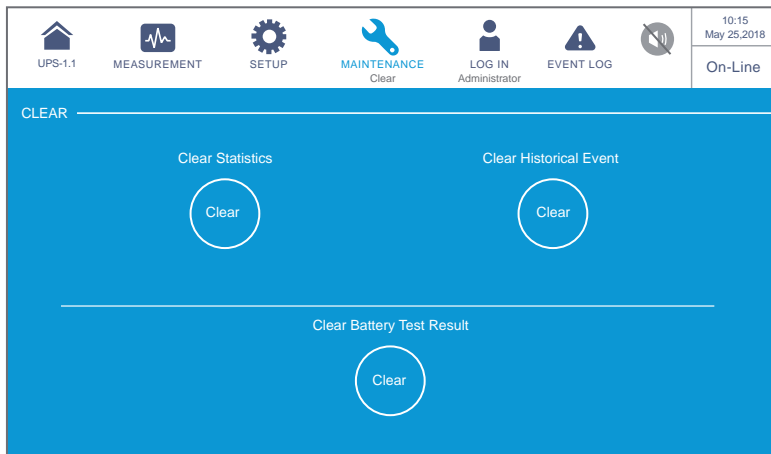

Item	Description
Clear Statistics	After selecting ' Clear ' and confirming clearance of statistics, all records of the statistics will be cleared. The clear action requires the Administrator password.
Clear Historical Event	After selecting ' Clear ' and confirming clearance of historical event logs, all historical event logs will be cleared. The clear action requires the Administrator password.
Clear Battery Test Result	After selecting ' Clear ' and confirming clearance of battery test result records, all battery test result records will be cleared. The clear action requires the Administrator password.

**NOTE:**

The records of (1) statistics, (2) historical event and (3) battery test result provide important information for system analysis and maintenance. Do not clear any of them without the consent of qualified service personnel.

7.11.6 Advanced Diagnosis

Route:  MAINTENANCE → **Advanced Diagnosis**

In the **ADVANCED DIAGNOSIS** screen shown below, you can check:

1. The system's STS temperature, battery temperature and fan speed.
2. A specific power module's inverter temperature and PFC temperature.

ADVANCED DIAGNOSIS			
UPS-1.1	MEASUREMENT	SETUP	MAINTENANCE Advanced Diagnosis
			LOG IN Administrator
			EVENT LOG
			10:15 May 25, 2018
			Bypass
	SYSTEM	POWER MODULE	
STS Temp. (°C)	26	26	26
Battery Temp. (°C)	-	-	-
Fan Speed (rpm)	0	0	-

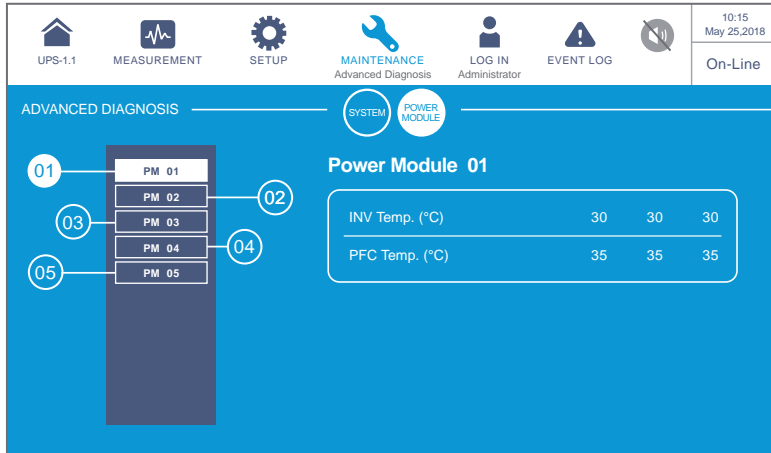

7.11.7 Version & S/N

Route:  MAINTENANCE → Version & S/N

In the **VERSION & S/N** screen shown below, you can check and upgrade relevant items' serial No. and firmware version. For detailed information, please refer to the following.

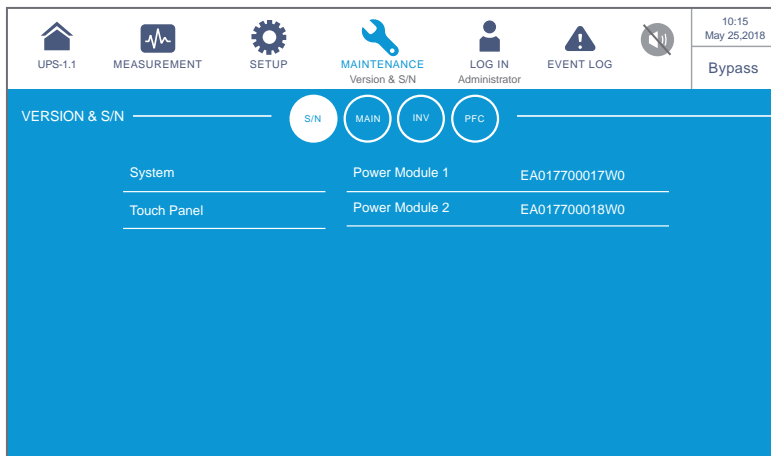

UPS-1.1 MEASUREMENT SETUP MAINTENANCE Version & S/N LOG IN Administrator EVENT LOG 10:15 May 25, 2018 Bypass

VERSION & S/N S/N MAIN INV PFC

	MCU	FPGA
COM #1	0H0017AR00.00.01	4A0000AD00.00.01
COM #2	0H0017AR00.00.01	4A0000AD00.00.01
System	0H0033AD00.01.00	4A0002AD00.00.01
Touch Panel	00.92	

Choose File

UPGRADE

UPS-1.1 MEASUREMENT SETUP MAINTENANCE Version & S/N LOG IN Administrator EVENT LOG 10:15 May 25, 2018 Bypass

VERSION & S/N S/N MAIN INV PFC

	MCU	FPGA	MCU	FPGA
PM 01	0H0014AR00.00.00	4A001AR00.00.00	PM 02	0H0014AR00.00.00
				4A001AR00.00.00

Choose File

UPGRADE

UPS-1.1 MEASUREMENT SETUP MAINTENANCE Version & S/N LOG IN Administrator EVENT LOG 10:15 May 25, 2018 Bypass

VERSION & S/N S/N MAIN INV PFC

	MCU	FPGA	MCU	FPGA
PM 01	0H0014AR00.00.00	4A001AR00.00.00	PM 02	0H0014AR00.00.00
				4A001AR00.00.00

Choose File

UPGRADE

Item	Sub Item	Description
S/N	System	Check the system's serial No.
	Touch Panel	Check the touch panel's serial No.
	Power Module#	Check a specific power module's serial No.
MAIN	COM#_ MCU/ FPGA	Check and update a specific COM's MCU or FPGA firmware version.
	System _ MCU/ FPGA	Check and update the system's MCU or FPGA firmware version.
	Touch Panel _ MCU/ FPGA	Check and update the touch panel's MCU or FPGA firmware version.
INV	PM #_ MCU/ FPGA	Check and update the MCU or FPGA firmware version of a specific power module's inverter.
PFC	PM #_ MCU/ FPGA	Check and update the MCU or FPGA firmware version of a specific power module's PFC.

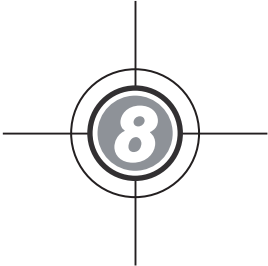

Optional Accessories

There are several optional accessories available for this DPH series UPS. Please refer to the table below for the optional accessories and their descriptions.

No.	Item	Function
1	Dust Filter	Prevents dust from entering into the UPS to ensure UPS reliability and to prolong product life.
2	Relay I/O Card	Increases the quantity of dry contacts.
3	EnviroProbe 1000/ EnviroProbe 1100/ EnviroProbe 1200	Monitors temperature, humidity and other connected monitoring devices in a room environment. The EnviroProbe 1000/ 1100/ 1200 should work with either an SNMP card or an EMS2000.
4	Battery Cabinet Temperature Sensor Cable	Detects the temperature of an external battery cabinet connected to the UPS.
5	Parallel Cable (5-meter long)	Connects the parallel UPSs.
6	Parallel Cable (10-meter long)	Connects the parallel UPSs.
7	Battery Management System	Monitors (1) each battery's voltage, (2) each battery pack's voltage and charging/ discharging current, and (3) battery environment temperature.
8	Battery Module (with batteries)	Supplies battery power to the critical loads connected to the UPS when a power failure occurs. For more information, please refer to 5.9 Battery Module (Optional) .
9	Battery Module (without batteries)	Provides the space for batteries to be installed. For how many batteries and what types of batteries that should be installed inside the empty battery module, please contact Delta service personnel for more information.



NOTE:

1. For detailed installation and operation of any accessory mentioned above, please refer to the **Quick Guide**, **User Guide**, or **Installation & Operation Guide** included in the package of the relevant optional accessory.
2. If you want to buy any accessory mentioned above, please contact your local dealer or customer service.



Maintenance

- **UPS**

1. UPS Cleaning:

Regularly clean the UPS, especially the slits, openings and filters, to ensure that the air freely flows into the UPS to avoid overheating. If necessary, use an air-gun to clean the slits and openings and replace the filters regularly to prevent any object from blocking or covering these areas.

2. UPS Regular Inspection:

- a. Monthly check the filters and yearly replace them.
- b. Regularly check the UPS every half year and inspect:
 - 1) Whether the UPS, LED indicators, and alarm function are operating normally.
 - 2) Whether the UPS works in bypass mode (normally, the UPS will work in normal mode). If yes, check if any error, overload, internal fault, etc. occurs.
 - 3) Whether battery voltage is normal. If the battery voltage is too high or too low, find the root cause.

- **Batteries**

The DPH series UPS uses sealed lead-acid batteries. The battery life depends on the temperature, the usage, and the charging/ discharging frequency. High temperature environments and high charging/ discharging frequency will quickly shorten the battery life. Please follow the suggestions below to ensure a normal battery lifetime.

1. Keep usage temperature between 59 ~ 77°F (15 ~ 25°C).
2. When the UPS needs to be stored for an extended period of time, the batteries must be recharged once every three months and the charging time must not be less than 24 hours each time.

- **Fans**

Higher temperatures shorten fan life. When the UPS is running, please check if all of the fans work normally and make sure if the ventilation air can move freely around and through the UPS. If not, replace the fans.



NOTE:

Please ask your local dealer or customer service for more maintenance information. Do not perform maintenance if you are not trained for it.



Troubleshooting

When you see the following alarm messages appear on the LCD, please follow the solutions shown below. If you see other alarm messages that are not listed in the table below, please contact Delta service personnel for assistance. Do not perform troubleshooting if you are not trained for it.

No.	Alarm Message	Possible Cause	Solution
1	Mains Input Volt/ Freq Out Range	<ol style="list-style-type: none"> 1. The Input/ Bypass Breaker (Q1) is turned off. 2. The main AC source's voltage or frequency is abnormal. 	<ol style="list-style-type: none"> 1. Please check if the Input/ Bypass Breaker (Q1) is turned off or not. If yes, please turn it on. 2. Please check if the main AC source's voltage or frequency is abnormal or not. If yes, please wait for the main AC source to be restored. 3. If the alarm message still exists after the solutions mentioned above have been executed, please contact service personnel.
2	Mains Input Volt Phase Seq Abnormal	The wiring is incorrect.	Please check the wiring and phase sequence of the main AC source, and contact service personnel for assistance.
3	Mains Input Breaker Off	The Input/ Bypass Breaker (Q1) is turned off.	<ol style="list-style-type: none"> 1. Please check if the Input/ Bypass Breaker (Q1) is turned off or not. If yes, please turn it on. 2. If the alarm message still exists after the solution mentioned above has been executed, please contact service personnel.
4	Bypass Input Volt Out Range	<ol style="list-style-type: none"> 1. The Input/ Bypass Breaker (Q1) is turned off. 2. The bypass AC source's voltage is abnormal. 	<ol style="list-style-type: none"> 1. Please check if the Input/ Bypass Breaker (Q1) is turned off or not. If yes, please turn it on. 2. Please check if the bypass AC source's voltage is abnormal or not. If yes, please wait for the bypass AC source to be restored. 3. If the alarm message still exists after the solutions mentioned above have been executed, please contact service personnel.

No.	Alarm Message	Possible Cause	Solution
5	Bypass Input Freq Out Range	<ol style="list-style-type: none"> The Input/ Bypass Breaker (Q1) is turned off. The bypass AC source's frequency is abnormal. 	<ol style="list-style-type: none"> Please check if the Input/ Bypass Breaker (Q1) is turned off or not. If yes, please turn it on. Please check if the bypass AC source's frequency is abnormal or not. If yes, please wait for the bypass AC source to be restored. If the alarm message still exists after the solutions mentioned above have been executed, please contact service personnel.
6	Bypass Input Volt Phase Seq Abnormal	The wiring is incorrect.	Please check the wiring and phase sequence of the bypass AC source, and contact service personnel for assistance.
7	Bypass Volt Out ECO Range	The bypass AC source's voltage or frequency exceeds the range for ECO mode.	Please check the bypass AC source's voltage or frequency. If it is abnormal, please wait for the bypass AC source to be restored.
8	Bypass Breaker Off	The Input/ Bypass Breaker (Q1) is turned off.	<ol style="list-style-type: none"> Please check if the Input/ Bypass Breaker (Q1) is turned off or not. If yes, please turn it on. If the alarm message still exists after the solution mentioned above has been executed, please contact service personnel.
9	Bypass STS Over Heat Warning	Heat dissipation is poor or components are damaged.	<ol style="list-style-type: none"> Check if any foreign matter blocks the fans or air inlet. If yes, remove the foreign matter. Decrease some loads. If the alarm message still exists after the solutions mentioned above have been executed, please contact service personnel.
10	Bypass STS Fault	The bypass static switch or its driving circuit is abnormal.	Please contact service personnel for assistance.

No.	Alarm Message	Possible Cause	Solution
11	Battery End of Discharge Imminent	The battery voltage is lower than the alarm value.	If there is no bypass power feeding to the system, please shut down the connected loads in accordance with normal procedures as soon as possible.
12	Battery End Of Discharge	The battery voltage is lower than the End-of-Discharge setup value.	If there is no bypass power feeding to the system, please shut down the connected loads in accordance with normal procedures as soon as possible.
13	Battery Over Charged	The charger is abnormal.	Please contact service personnel for assistance.
14	Battery Disconnected	<ol style="list-style-type: none"> 1. The batteries are not connected. 2. The battery breaker is turned off. 	<ol style="list-style-type: none"> 1. Please check if the batteries are properly connected. 2. Please check if the battery breaker is turned off or not. If yes, please turn it on. 3. If the alarm message still exists after the solutions mentioned above have been executed, please contact service personnel.
15	Battery Life Expired	<ol style="list-style-type: none"> 1. The battery replacement date is due. 2. The system date is wrongly set. 	<ol style="list-style-type: none"> 1. Please check if the battery replacement date is due or not. If yes, please contact service personnel for assistance. 2. Please check the setting of the system date. If there is any error, please correct it.
16	Battery Reversed	The battery wiring is wrong.	Check the battery wiring. If there is any error or abnormality, please contact service personnel for assistance.
17	Battery Test Fail	The battery wiring is wrong or battery abnormalities exist.	Check the batteries. If wrong battery wiring or battery abnormalities exist, please contact service personnel for assistance.

No.	Alarm Message	Possible Cause	Solution
18	Battery Ground Fault	The battery grounding is wrong or the input dry contact configuration is wrong.	<ol style="list-style-type: none"> 1. Check if the battery wiring is normal or not. 2. Check if the input dry contact configuration is normal or not. 3. If the alarm message still exists after the solutions mentioned above have been executed, please contact service personnel.
19	Battery Breaker OFF	The battery breaker is turned off.	<ol style="list-style-type: none"> 1. Please check if the external battery breaker is turned off or not. If yes, please turn it on. 2. If the alarm message still exists after the solution mentioned above has been executed, please contact service personnel.
20	Battery Over Temperature	The battery temperature is too high or the batteries are abnormal.	<ol style="list-style-type: none"> 1. Improve ventilation to reduce the battery temperature. 2. Check if the batteries are abnormal or not. If yes, please contact service personnel for assistance.
21	Battery Under Temperature	The battery temperature is too low or the batteries are abnormal.	<ol style="list-style-type: none"> 1. Check the battery constant temperature equipment. 2. Check if the batteries are abnormal or not. If yes, please contact service personnel for assistance.
22	Output Overload Warning	The connected loads exceed the rated value.	Please decrease the loads.
23	Output Overload Shutdown	The connected loads exceed the rated value for a long time.	<ol style="list-style-type: none"> 1. After overload shutdown, the connected loads will be supplied by the bypass. Please decrease the loads to let the system re-start automatically. 2. If the alarm message still exists after the solution mentioned above has been executed, please contact service personnel.
24	INV Volt Abnormal	The inverter's output voltage is too high or too low.	Please contact service personnel for assistance.

No.	Alarm Message	Possible Cause	Solution
25	INV Over Current Warning	The inverter's output current is too high.	Please contact service personnel for assistance.
26	INV Over Current Shutdown	The inverter's output current is too high.	Please contact service personnel for assistance.
27	INV Output Current Unbalance	The connected loads are abnormal or the power modules are damaged.	Please contact service personnel for assistance.
28	Output Breaker Off	The Output Breaker (Q3) is off.	<ol style="list-style-type: none"> 1. Please check if the Output Breaker (Q3) is turned off or not. If yes, please turn it on. 2. If the alarm message still exists after the solution mentioned above has been executed, please contact service personnel.
29	PM Redundancy Loss	The connected loads exceed the redundancy setting.	<ol style="list-style-type: none"> 1. Please reduce the loads. 2. Please reset the power module redundancy setting. Please refer to 7.10.3 Output Setting.
30	System Fan Fault	The system's fan components are damaged.	Please contact service personnel for assistance.
31	STS Module Fan Abnormal	The STS module's fan components are damaged.	Please contact service personnel for assistance.
32	PM #n Fan Abnormal	The #n power module's fan components are damaged.	Please contact service personnel for assistance.
33	Replace Dust Filter	The filter replacement date is due.	Please contact service personnel for assistance.
34	Parallel Unit Config Incompatible - AC In Type	There are conflicts between the parallel UPS units' AC input settings.	Check if the AC input settings among the parallel UPS units are correct or not, and contact service personnel for assistance.
35	Parallel Unit Config Incompatible - Output Type	There are conflicts between the parallel UPS units' output settings.	Check if the output settings among the parallel UPS units are correct or not, and contact service personnel for assistance.

No.	Alarm Message	Possible Cause	Solution
36	Parallel Unit Config Incompatible - Bat Type	<ol style="list-style-type: none"> 1. There are conflicts between the parallel UPS units' battery settings. 2. The input dry contact setting for the generator is abnormal. 	<ol style="list-style-type: none"> 1. Check if the battery settings among the parallel UPS units are correct or not, and contact service personnel for assistance. 2. Check the input dry contact setting.
37	EXT Parallel Comm Loss	The parallel cable is loose or the circuit board has abnormalities.	Check if the parallel cable is firmly connected or not, and contact service personnel for assistance.
38	Local Comm Loss	The system's internal communication cable is loose or the circuit board has abnormalities.	Please contact service personnel for assistance.
39	EXTCAN Bus Abnormal - Physical	The parallel cable is loose or the circuit board has abnormalities.	Check if the parallel cable is firmly connected or not, and contact service personnel for assistance.
40	INTCAN Bus Abnormal - Physical	The system's internal communication cable is loose or the circuit board has abnormalities.	Please contact service personnel for assistance.
41	MONCAN Abnormal - Physical	The system's internal communication cable is loose or the circuit board has abnormalities.	Please contact service personnel for assistance.
42	PFC #n MONCAN Comm Loss	The circuit board has abnormalities.	Please contact service personnel for assistance.
43	Parallel IO Abnormal	The system's internal communication cable is loose or the circuit board has abnormalities.	Please contact service personnel for assistance.
44	INV #n PLL Bus Abnormal	The main AC source's voltage is changed or the circuit board has abnormalities.	<p>Please confirm if the main AC source's voltage is abnormal or not.</p> <p>If yes, please wait for the main AC source to be restored to normal.</p> <p>If no, please contact service personnel for assistance.</p>

No.	Alarm Message	Possible Cause	Solution
45	System Aux Pwr Fault	The #n auxiliary power card has abnormalities.	Please contact service personnel for assistance.
46	CSU Aux Pwr #n On Repair	The #n auxiliary power card is not inserted.	Please contact service personnel for assistance.
47	COM Card #n Absent	The #n parallel communication card is abnormal.	Please contact service personnel for assistance.
48	PM#n Abnormal Absent	The #n power module is abnormally removed or the power outage occurs.	Please contact service personnel for assistance.
49	STS Card FPGA Config Abnormal	The system control card is abnormal.	Please contact service personnel for assistance.
50	Soft Start Fail	The #n power module is abnormal.	Please contact service personnel for assistance.
51	PM #n PFC Input Current Unbalance	The #n power module is abnormal.	Please contact service personnel for assistance.
52	PFC #n Over Heat Warning	The fans are abnormal.	<ol style="list-style-type: none"> 1. Check if any foreign matter blocks the fans or not. If yes, remove the foreign matter. 2. Contact service personnel for assistance.
53	PFC #n Over Heat Shutdown	The fans are abnormal.	<ol style="list-style-type: none"> 1. Check if any foreign matter blocks the fans or not. If yes, remove the foreign matter. 2. Contact service personnel for assistance.
54	PFC #n DC Bus Over Shutdown	The #n power module is abnormal.	Please contact service personnel for assistance.
55	PFC #n DC Bus Under Shutdown	The #n power module is abnormal.	Please contact service personnel for assistance.
56	INV #n Over Heat Warning	The fans are abnormal.	<ol style="list-style-type: none"> 1. Check if any foreign matter blocks the fans or not. If yes, remove the foreign matter. 2. Contact service personnel for assistance.

No.	Alarm Message	Possible Cause	Solution
57	INV #n Over Heat Shutdown	The fans are abnormal.	<ol style="list-style-type: none"> 1. Check if any foreign matter blocks the fans or not. If yes, remove the foreign matter. 2. Contact service personnel for assistance.
58	INV #n DC Bus Over Shutdown	The #n power module is abnormal.	Please contact service personnel for assistance.
59	INV #n DC Bus Under Shutdown	The #n power module is abnormal.	Please contact service personnel for assistance.
60	PFC Fuse Open	The #n power module is abnormal.	Please contact service personnel for assistance.
61	Battery Fuse Open	The #n power module is abnormal.	Please contact service personnel for assistance.
62	Charger Fuse Open	The #n power module is abnormal.	Please contact service personnel for assistance.
63	INV #N Output Fuse Open	The #n power module is abnormal.	Please contact service personnel for assistance.
64	Output Relay Fault	The #n power module is abnormal.	Please contact service personnel for assistance.
65	PM Repair Switch Open	The #n power module's switch is in the OFF status.	<ol style="list-style-type: none"> 1. Please turn on the #n power module's switch. 2. If the alarm message still exists after the solution mentioned above has been executed, please contact service personnel.
66	Over OTP Auto Recover Limit	The #n power module activates its own abnormal protection mechanism to re-start automatically more than 3 times.	Please contact service personnel for assistance.
67	Over DC Bus OVP Auto Recover Limit	The #n power module activates its own abnormal protection mechanism to re-start automatically more than 3 times.	Please contact service personnel for assistance.

No.	Alarm Message	Possible Cause	Solution
68	Over OCP Auto Recover Limit	The #n power module activates its own abnormal protection mechanism to re-start automatically more than 3 times.	Please contact service personnel for assistance.
69	INV Volt Abnormal	<ol style="list-style-type: none"> 1. The output to the connected loads is abnormal. 2. The #n power module's output voltage is too high or too low. 	Please contact service personnel for assistance.
70	PWM Carrier Fault	<ol style="list-style-type: none"> 1. The system's internal communication cable is loose. 2. The circuit board has abnormalities. 	Please contact service personnel for assistance.
71	INV PLL Ref Bus Abnormal	<ol style="list-style-type: none"> 1. The system's internal communication cable is loose. 2. The circuit board has abnormalities. 	Please contact service personnel for assistance.
72	Emergency Pwr Off	The EPO button is pressed.	<ol style="list-style-type: none"> 1. Please confirm if the EPO button is pressed or not. If yes, restart the UPS in accordance with the normal startup procedures after the relevant abnormalities are eliminated. 2. If the alarm message still exists, please contact service personnel for assistance.
73	Load on manual bypass	The Manual Bypass Breaker (Q2) is turned on.	<ol style="list-style-type: none"> 1. Please confirm if the Manual Bypass Breaker (Q2) is turned on or not. If yes, restart the UPS in accordance with the normal startup procedures after the relevant abnormalities are eliminated. 2. If the alarm message still exists, please contact service personnel for assistance.

No.	Alarm Message	Possible Cause	Solution
74	Charger Volt Abnormal	The charger is abnormal.	Please contact service personnel for assistance.
75	Charger Current Abnormal	The charger is abnormal.	Please contact service personnel for assistance.
76	Charger Over Heat warning	The fans are abnormal.	<ol style="list-style-type: none"> 1. Check if any foreign matter blocks the fans or not. If yes, remove the foreign matter. 2. Contact service personnel for assistance.
77	Charger Over Heat Shutdown	The fans are abnormal.	<ol style="list-style-type: none"> 1. Check if any foreign matter blocks the fans or not. If yes, remove the foreign matter. 2. Contact service personnel for assistance.

**NOTE:**

If the alarm still exists after the above possible causes are eliminated, please contact your dealer or customer service.

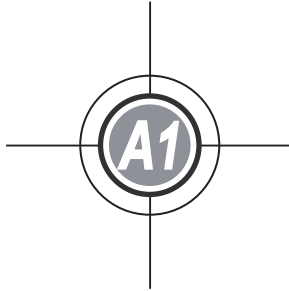

Technical Specifications

Model		DPH			
UPS Capacity		15kVA/ 15kW	30kVA/ 30kW	45kVA/ 45kW	60kVA/ 60kW
Input	Nominal Voltage	120/208 Vac, 127/220 Vac (3Φ4W + G)			
	Voltage Range	96 ~ 146Vac (full load)			
	Current Harmonic Distortion	≤ 3% *1			
	Power Factor	> 0.99			
	Frequency Range	40 ~ 70 Hz			
Output	Voltage	120/208 Vac, 127/220 Vac (3Φ4W + G)			
	Voltage Harmonic Distortion	≤ 2% (linear load)			
	Power Factor	1			
	Frequency	50/60 Hz			
	Overload Capability	≤ 125% : 10 minutes ; ≤ 150% : 1 minute; > 150% : 1 second			
Display		10" Touch Panel			
Interface	Standard	External battery temperature dry contact × 4, External switch/ breaker status dry contact × 4, Output dry contact × 6, Input dry contact × 4, Parallel port × 4, USB type A × 2, USB type B × 1, RS-232 port × 1, MODBUS port × 1, BMS (RJ45) × 1, Ethernet × 1, SMART slot × 1, REPO × 1			
Efficiency	Online Mode	up to 95%			
	ECO Mode	98%			
Battery	Nominal Voltage	± 168 Vdc			
	Charge Voltage	± 190V (adjustable from 182 to 196Vdc)			
	Protection of Battery Deep Discharge	Yes			

Model		DPH			
UPS Capacity		15kVA/ 15kW	30kVA/ 30kW	45kVA/ 45kW	60kVA/ 60kW
Environment	Operating Altitude	3280 ft (1000 meters) (without derating)			
	Operating Temperature	32 ~ 104°F (0 ~ 40°C)			
	Relative Humidity	< 95% (non-condensing)			
	Audible Noise	< 70 dBA * ² (full load)		< 72 dBA * ² (full load)	
		< 65 dBA (< 70% load)		< 67 dBA (< 70% load)	
IP Degree of Protection	IP 20				
Others	Parallel Redundancy	Yes * ³			
	Emergency Power Off	Yes (remote as default; local as optional)			
	Battery-start	Yes			
Physical	Dimensions (W x D x H)	23.6" x 33.5" x 78.7" (600 x 850 x 2000 mm)			
	Weight	UPS Frame: 562 lb (255 kg) (without power modules)			
		Power Module (optional): 46.3 lb (21 kg)/ 1 PC			
		Battery Module (optional, with batteries): 52.2 lb (23.7 kg)/ 1 PC			



NOTE:

- *¹: When input vTHD is < 1% under linear load conditions.
- *²: At a distance of 3.28 ft (1 meter) in front of the UPS.
- *³: For UPS parallel information and application, please contact Delta service personnel.
- Please refer to the rating label for the safety rating.
- All specifications are subject to change without prior notice.

The logo features a central circle containing the text 'A2'. This circle is surrounded by a larger, fainter circle. Four thin lines extend from the center of the circles towards the top, bottom, left, and right edges of the page.

Warranty

Seller warrants this product, if used in accordance with all applicable instructions, to be free from original defects in material and workmanship within the warranty period. If the product has any failure problem within the warranty period, Seller will repair or replace the product at its sole discretion according to the failure situation.

This warranty does not apply to normal wear or to damage resulting from improper installation, operation, usage, maintenance or irresistible force (i.e. war, fire, natural disaster, etc.), and this warranty also expressly excludes all incidental and consequential damages.

Maintenance service for a fee is provided for any damage out of the warranty period. If any maintenance is required, please directly contact the supplier or Seller.



WARNING:

The individual user should take care to determine prior to use whether the environment and the load characteristic are suitable, adequate or safe for the installation and the usage of this product. The User Manual must be carefully followed. Seller makes no representation or warranty as to the suitability or fitness of this product for any specific application.

No. 501325710306
Version : V 3.6
Release Date : 2021_01_29

- Global Headquarter

Taiwan

Delta Electronics Inc.
39 Section 2, Huandong Road, Shanhua District,
Tainan City 74144, Taiwan
T +886 6 505 6565
E ups.taiwan@deltaww.com

- Regional Office

The United States

Delta Electronics (Americas) Ltd.
46101 Fremont Blvd. Fremont, CA 94538
T +1 510 344 2157
E ups.na@deltaww.com

Australia

Delta Energy Systems Australia Pty Ltd.
Unit 20-21, 45 Normanby Road, Notting Hill VIC 3168, Australia
T +61 3 9543 3720
E ups.australia@deltaww.com

South America

Delta Greentech (Brasil) S/A
Rua Itapeva, 26 - 3° andar Edifício Itapeva One - Bela Vista
01332-000 - São Paulo - SP - Brazil
T +55 11 3568 3850
E ups.brazil@deltaww.com

Thailand

Delta Electronics (Thailand) Public Co.,Ltd.
909 Soi 9, Moo 4, E.P.Z., Bangpoo Industrial Estate, Tambon Prakasa,
Amphur Muang-samutprakarn, Samutprakarn Province 10280, Thailand
T +662 709-2800
E ups.thailand@deltaww.com

China

Delta GreenTech (China) Co., Ltd.
238 Minxia Road, Pudong, Shanghai, 201209 P.R.C
T +86 21 5863 5678
+86 21 5863 9595
E ups.china@deltaww.com

South Korea

Delta Electronics (Korea), Inc.
1511, Byucksan Digital Valley 6-cha, Gasan-dong, Geumcheon-gu,
Seoul, Korea, 153-704
T +82-2-515-5303
E ups.south.korea@deltaww.com

Singapore

Delta Electronics Int'l (Singapore) Pte Ltd.
4 Kaki Bukit Ave 1, #05-04, Singapore 417939
T +65 6747 5155
E ups.singapore@deltaww.com

India

Delta Power Solutions (India) Pvt. Ltd.
Plot No. 43, Sector-35, HSIIDC, Gurgaon-122001, Haryana, India
T +91 124 4874 900
E ups.india@deltaww.com

EMEA

Delta Electronics (Netherlands) BV
Zandsteen 15, 2132MZ Hoofddorp, The Netherlands
T +31 20 655 09 00
E ups.netherlands@deltaww.com

Japan

Delta Electronics (Japan), Inc.
2-1-14 Shibadaimon, Minato-Ku, Tokyo, 105-0012, Japan
T +81-3-5733-1111
E jpstps@deltaww.com



5013257103